

# 4 Point Method / Measurement of low resistances

(Item No.: P2410101)

## Curricular Relevance

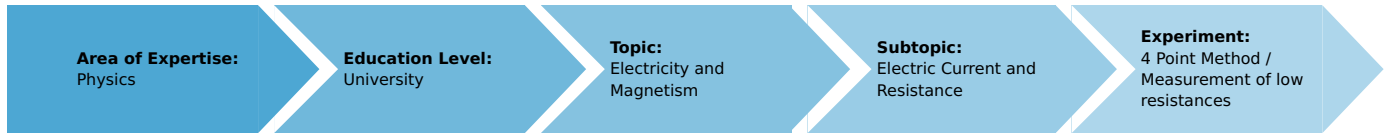

### Difficulty



Difficult

### Preparation Time



1 Hour

### Execution Time



1 Hour

### Recommended Group Size



2 Students

### Additional Requirements:

### Experiment Variations:

### Keywords:

Ohm's law, resistivity, contact resistance, conductivity, four-wire method of measurement

## Overview

### Short description

The resistances of various DC conductors are determined by recording the current/voltage characteristic. The resistivity of metal rods and the contact resistance of connecting cords are calculated.

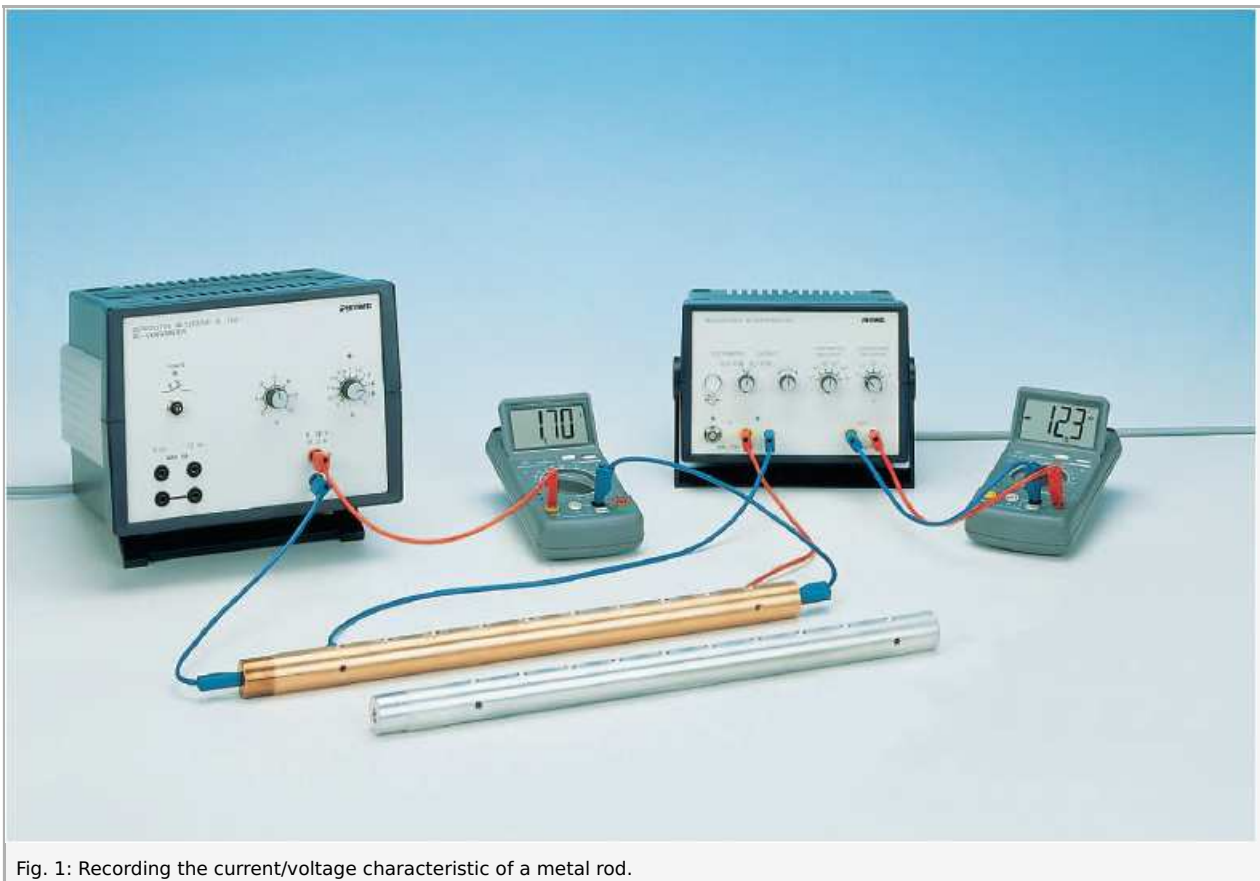

Fig. 1: Recording the current/voltage characteristic of a metal rod.

## Equipment

Position	Material	Order nr.	Quantity
1	Universal measuring amplifier	13626-93	1
2	PHYWE Power supply 0-12 V DC/ 6 V, 12 V AC, 230 V	13505-93	1
3	Heat conductivity rod, Cu	04518-11	1
4	Heat conductivity rod, Al	04518-12	1
5	Digital multimeter 2005	07129-00	2
6	Connection box	06030-23	1
7	Connecting cord, 32 A, 2000 mm, yellow	07365-02	2
8	Connecting cord, 32 A, 750 mm, yellow	07362-02	2
9	Connecting cord, 32 A, 750 mm, blue	07362-04	1
10	Connecting cord, 32 A, 500 mm, red	07361-01	2
11	Connecting cord, 32 A, 500 mm, blue	07361-04	1
12	Connecting cord, 32 A, 250 mm, red	07360-01	1
13	Connecting cord, 32 A, 250 mm, blue	07360-04	1
14	Connecting cord, 100 mm, yellow	07359-02	2

## Tasks

1. To plot the current/voltage characteristics of metal rods (copper and aluminium) and to calculate their resistivity.
2. To determine the resistance of various connecting cords by plotting their current/voltage characteristics and calculating the contact resistances.

## Set-up and procedure

1. Connect the metal rod to the mains with an ammeter. Measure the voltage drop across the rod at two sockets on the side, using the amplifier (four-wire method of measurement, see Fig. 1).

Settings of the amplifier: Low drift,  $R = 10^4 \Omega$ , Amplification:  $10^3$ , Timer constant: 0 sec.

2. Connect a connecting cord into the circuit in place of the metal rod, using two double sockets with cross hole (Fig. 2a). Connect the voltmeter to the sockets of the connecting cord connector (similar to the four-wire method; measuring  $U_1$  as shown in Fig. 2). The voltage drops not only across the pure line resistor  $R_1$  but also across the two line/plug contact resistors  $R_{1p}$  as well.

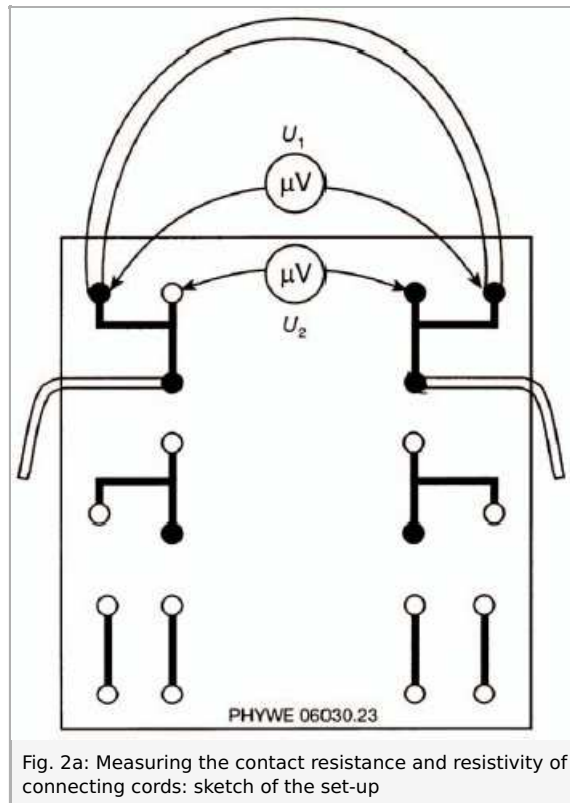

Fig. 2a: Measuring the contact resistance and resistivity of connecting cords: sketch of the set-up

Determine the total resistance of the connecting cord with connectors by connecting the Voltmeter to the holes in the double sockets (measuring  $U_2$  in Fig. 2). The plug/double socket contact resistances  $R_{pd}$  are obtained by comparing  $U_1$  and  $U_2$ .

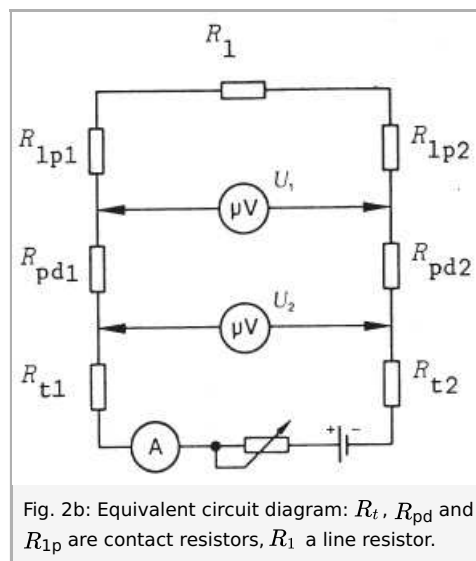
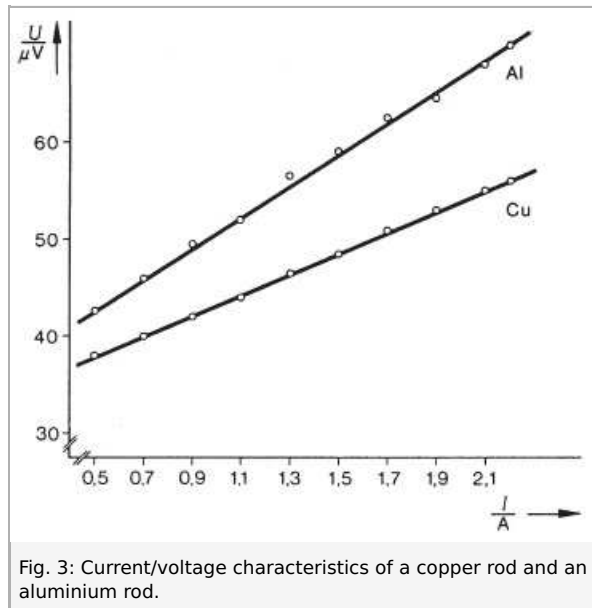

Fig. 2b: Equivalent circuit diagram:  $R_t$ ,  $R_{pd}$  and  $R_{1p}$  are contact resistors,  $R_1$  a line resistor.



### Theory and evaluation

The resistivity  $\rho$  of the metal is determined from the resistance  $R$  of the rod and its dimensions. The rod has a diameter of 2.5 cm (cross section  $A = 4.91 \times 10^{-4}$  ) and is 31.5 cm long (length  $l$  ) between the two voltmeter connections.

$$\rho = \frac{A \cdot R}{l} \quad (1)$$

Ohm's law

$$U = R \cdot I \quad (2)$$

The regression lines of the measured values in Fig. 3 give

$$R_{Cu} = 11.5 \pm 0.3 \mu\Omega$$

for the copper rod, and

$$R_{Al} = 19.1 \pm 0.2 \mu\Omega$$

for the aluminium rod.

The values of resistivity obtained using equation (1) are:

	measured $\rho/10^{-8}\Omega$	Bibliographic data at 20° $\rho/10^{-8}\Omega$
Cu	1.79	1.68
Al	2.98	2.72

The aluminium rod is not pure, it contains other additions.

The copper wire in the cords has a cross section  $A$  of  $2.5 \text{ mm}^2$  .

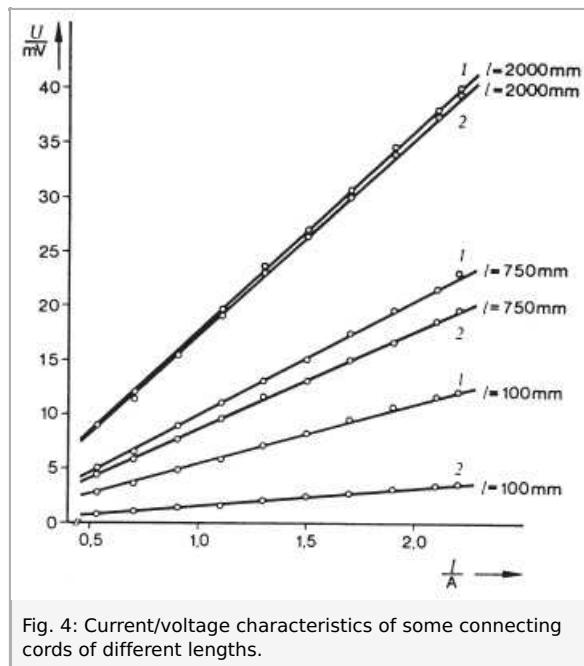

Fig. 4: Current/voltage characteristics of some connecting cords of different lengths.

Fig. 4: Current/voltage characteristics of some connecting cords of different lengths.

The line resistance  $R_1$  of the connecting cords can be calculated using (1):

$$R_1 = \rho \cdot \left(\frac{l}{A}\right)$$

The line/plug contact resistance can be established from the difference between the line resistance  $R_1$  calculated and the resistance  $R_1$  measured.

$R_1$  is determined from the slope of the straight lines in Fig. 4.

$l/m\text{m}$		$R_1/m\Omega$	$R_1/m\Omega$	$(R_1 - R_1)/m\Omega$
100	1	0.67	5.6	4.9
	2		1.6	0.9
750	1	5.0	10.7	5.7
	2		9.1	4.1
2000	1	13.4	18.6	5.2
	2		18.2	4.8

The average of the line/plug contact resistance values is:

$$R_{1p} = \frac{R_1 - R_1}{2} = 2.1m\Omega$$

The plug/double socket contact resistance can be determined by comparing the voltages  $U_1$  and  $U_2$  (see Figs. 2):

$$R_{pd} = \frac{U_1 - U_2}{I}$$

In accordance with Figs. 2b,

$$U_1 = R_1 \cdot I$$

with

$$R_1 = R_1 + R_{1p_1} + R_{1p_2}$$

and

$$U_2 = R_2 \cdot I$$

with

$$R_2 = R_1 + R_{pd_1} + R_{pd_2}$$

For a connecting cord 100 mm long the measured values give:

$$R_1 = 5.6m\Omega$$

The plug/double socket contact resistance is therefore of the order of

$$R_{pd} = 30m\Omega$$