

Table of Contents

Table of Contents	1
UniTrain®	2
UniTrain System	2

UniTrain®

UniTrain is a multimedia e-learning system with integrated, mobile electronics lab for general education and advanced training in electrical engineering and electronics.

UniTrain System



UniTrain System

- Computer-based training and experimentation system for vocational and further training and education
- Multimedia combines cognitive and hands-on (haptic) training units into a comprehensive unified concept
- Areas of basic and advanced electrical engineering, electronics and automotive technology
- Enabling students to acquire skills in the handling of equipment
- Wide range of multimedia courses available for study in school or in professional and advanced training
- Self-contained and usable anywhere at any time
- Multimedia learning environment with high degrees of motivation
- Maximum learning effectiveness in laboratories, at work or at home
- Guarantor for effective and efficient study
- Instruments with virtual display together with experiment hardware
- LabSoft, an open experiment delivery platform
- Courses teach the theoretical building blocks and provide experiments
- Intelligent measurement interface supplies analog and digital measuring and control I/O
- High quality item of laboratory equipment with virtual instruments
- Students' progress monitored and electronically documented on the basis of fault finding experiments
- Faults simulated by the hardware as well as tests of knowledge

Basic equipment set UniTrain system, consisting of:

Basic equipment set UniTrain system, consisting of:

The following courses require no Experimenter:

SO4204-3A, -3C, -4M, -4N, -5V, -6M, -6N, -6W, -6X, -6Y, -7C, -7F, -7X, -8H, -8U, -8V, -8Y

The following courses require one Experimenter:

All courses for topics in electronics, digital technology, electrical machines (not -7X), mechatronics (IMS) and process technology (IPA) plus courses SO4204-3B, -4A, -4B, 4C, -4D, -4F, -4K, -4L, -4P, -6H, -7A, -7B, -7H, -7J, -7Q, -8T, -9A, -9B, -9D, -9K, -9T, -9U, -9V, -9X, -9Y and CO4205-1H, -1J, -1K, -1L, -1M.

The following courses require two Experimenters:

All courses for topics in instrumentation technology, control technology (not -8H) plus courses SO4204-3P, -4H, -6J, -6Z, -7D, -7E, -7G, -7K, -7M, -7N, -9E, -9F, -9L, -9M, -9Q, -9R and -9S.

The following courses require three Experimenters:

SO4204-6V, -7P, -8N, -9J and 9N

When using digital multimeter LM2330 an additional Experimenter is recommended for use as a docking station using an IrDa interface.

Pos.	Product name	Bestell-Nr.	Anz.
1	UniTrain Interface with virtual instruments (basic VI)	CO4203-2A	1

The UniTrain Interface is the central unit of the UniTrain system. It incorporates all inputs and outputs, switches, power and signal sources and measurement circuitry needed to perform experiments. The Interface is controlled via the connected PC.

Equipment:

- 32-bit processor with storage memory for measurements
- USB interfaces, transfer rate 12 Mbits/s
- WLAN/WiFi interface, 2.4 GHz, IEEE 802.11 b/g/n
- Simultaneous connection of any number of Experimenters via serial bus system
- High-quality designer casing with aluminium feet and surface-hardened Plexiglas front panel
- Suitable for accommodating in training panel frames for DIN A4 training panels
- Designed for connection of 2-mm safety measuring leads
- Multi-coloured LEDs for displaying status
- Adjustable analog output, +/-10 V, 0.2 A, DC – 5 MHz, via BNC and 2-mm sockets
- 4 Analog differential amplifier inputs with 10 MHz band width, safe for voltages up to 100 V, sampling rate 100 mega samples, 9 measuring ranges, memory depth 4 x 8 k x 10 bits, inputs via BNC (2 inputs) or 2-mm sockets (4 inputs)
- 2 Analog inputs for current measurement, overcurrent-protected up to 5 A, sampling rate 250 kilo samples, 2 measuring ranges, resolution 12 bits, connection via 2-mm sockets
- 16-bit digital signal output, of which 8 bits are accessed via 2-mm sockets, TTL/CMOS, clock frequency 0 – 100 kHz, electric strength +/- 15 V
- 16-bit digital signal input, of which 8 bits are accessed via 2-mm sockets, memory depth 16 bit x 2 k, TTL/CMOS, sampling rate 0 – 100 kHz, electric strength +/- 15 V,
- 8 Relays, 24 V DC/1 A, of which 4 are accessed via 2-mm sockets
- Dimensions: 29.6 x 19 x 8.6 cm



- External power supply with wide range input 100-264 V, 47-63 Hz, output 24 V/5 A
- Weight (including power supply): 2.1 kg

Virtual instruments (meters and sources):

- 2 x Voltmeter VIs, 2 x Ammeter VIs: AC, DC, 9 ranges, 100mV to 50V, true RMS, AV
- 1 x VI with 8 relays, 1 x Multimeter VI: multimeter display (optional LM2330, LM2331 or LM2322) in LabSoft
- 1 x 2-channel ammeter VI: AC, DC, 2 ranges, 300 mA and 3 A, TrueRMS, AV
- 1 x 2-channel voltmeter VI: AC, DC, 9 ranges, 100 mV to 50 V, TrueRMS, AV
- 1 2-/4-channel oscilloscope: band width 10 MHz, 25 time ranges, 100 ns/div to 10 s/div, 9 ranges 20 mV/div to 10 V/div, trigger and pre-trigger, XY and XT modes, cursor function, addition and multiplication function for 2 channels
- 1 x Adjustable DC voltage VI 0 - 10 V
- 1 x Function generator VI: 0.5 Hz - 5 MHz, 0 - 10 V, sine, square, triangular,
- 1 x Arbitrary generator VI, 1 x Pulse generator VI
- 1 x VI with 16 digital outputs, 1 x VI with 16 x digital inputs, 1 x VI with 16 digital input/outputs. Display modes: binary, hex, decimal and octal numerals
- 1 x Three-phase power supply VI, 0 - 150 Hz, 0 - 14 Vrms, 2 A (requires CO4203-2B)
- 1 x Adjustable DC power supply VI, 3 x (-20 V - +20 V), 2 A (requires CO4203-2B)
- 1 x Three-phase power supply VI with additional phase-shift and clock rate adjustment (requires CO4203-2B)

Includes:

- Interface
- Power supply
- Power lead
- USB cable
- CD with basic software
- Operating manual

System requirements:

- Personal computer with Windows Vista, Windows 7, Windows 8, Windows 8.1, Windows 10 (32 or 64 bit version)
- CD-ROM drive for installing software
- USB port for connection to Interface

2 UniTrain Experimenter

CO4203-2B

2

UniTrain Experimenter for coupling to the UniTrain Interface or to other Experimenter modules.

Equipment:

- Connects to the UniTrain Interface and additional Experimenters via UniTrain bus
- UniTrain bus connection for experiment cards
- High-quality designer casing with aluminium feet and surface-hardened Plexiglas front window
- Suitable for accommodating training panel frames for DIN A4 training panels
- Fixed and variable voltages available via 8 2-mm sockets
- Designed for connection of 2-mm safety measuring leads
- Accommodates UniTrain experiment cards
- Eject mechanism for UniTrain experiment cards with return spring
- Accommodates a breadboard for experimenting with discrete components and integrated circuits
- Accommodates a multimeter using IrDa interface
- Dimensions: 29.6 x 19 x 8.6 cm
- Weight: 1.0 kg

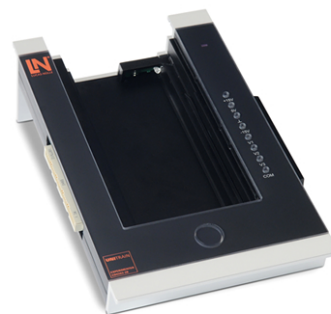

3 UniTrain-I measurement accessories, shunts and connection cables

SO4203-2J

1

Shunt resistors on a PCB, for current measurement using the analog inputs of the UniTrain system.

- 6 Shunt resistors: 2 x 1 ohm, 2 x 10 ohm, 2 x 100 ohm
- Screen print of symbols for identifying resistors, the voltage taps and current inputs
- 24 x 2-mm sockets
- Dimensions: 100 x 40 mm

Set of connection cables 2mm (22 pcs) for UniTrain consisting of:

- 8 x connection leads 2mm, 15cm, blue
- 4 x connection leads 2mm, 15cm, yellow
- 2 x connection leads 2mm, 45cm, black
- 2 x connection leads 2mm, 45cm, yellow
- 2 x connection leads 2mm, 45cm, red
- 2 x connection leads 2mm, 45cm, blue
- 2 x adapter leads 4mm to 2mm, 50cm, white
- 10 x 2-mm connector plugs / Plug spacing 5mm

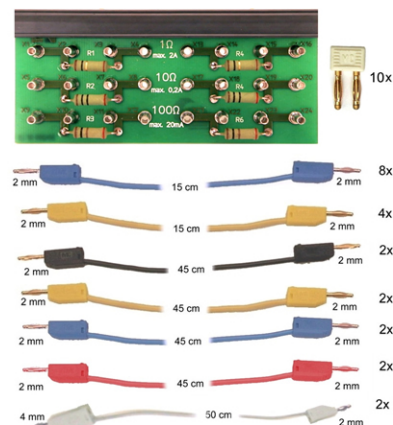

Additionally recommended

Pos.	Product name	Bestell-Nr.	Anz.
4	Multi13S digital multimeter	LM2330	1
	<p>Universal precision lab multimeter and temperature meter with IR interface for high-quality, universal measurement and testing in educational settings, power plants, process control installations etc.</p> <ul style="list-style-type: none"> • 3¾-digit multimeter; resolution: $\pm 3,100$ digits • Measurement classification CATII-1000V • Can be connected to UniTrain system via IR interface • Voltage and current measuring ranges: 30mV-1000V DC, 3V-1000V AC; 3mA-16A DC; 30mA-10A AC • Resistance ranges: 30ohm-30Mohm • Special functions: for temperature measurements using PT100/1000 thermocouple (optional accessory) • Continuity and diode testing • Automatic range selection and battery shut-off, min./max. and data hold function • Safety fuse for current measurement range up to 300mA • Protection against high currents in the mA range for nominal voltage of 1000V • Display with bar chart and backlighting • Includes protective sleeve, measuring leads, 1 x spare fuse, 9V battery, calibration certificate 		

5	UniTrain storage case for one system	CO4203-2Y	1
---	---	-----------	---

Sturdy aluminium case with moulded foam block to accommodate a complete UniTrain system (without equipment)

- Capable of accommodating 1 Interface, 2 Experimenters, 1 power supply as well as cables and smaller accessories
- Lockable padlock; stable padlock hinge
- Colours: aluminium, black, chrome
- Dimensions: 610 x 480 x 100 mm
- Weight: 4,6 kg

