

Table of Contents

Table of Contents	1
Power Engineering Smart Grid Micro Grid	2
Renewable Energies	2
EPH 2 Advanced Photovoltaics Trainer (PV)	3
EPH 2.1 Investigating solar modules	4
EPH 2.2 Design of photovoltaic systems in an isolated power network	19
EPH 2.3 Design of photovoltaic systems for grid-parallel operation	35
EPH 2.4 Solar pumps	49

Power Engineering | Smart Grid | Micro Grid

Training systems on the generation, distribution and management of electrical energy:

- Power engineering training system, distribution training system
- Energy generation training system, renewable energy generation training system
- Transformer training system, high-voltage transmission lines training system, protective systems training system
- Energy management training system, smart grid training systems

The Lucas-Nülle training systems have been designed in anticipation of the newest developments:

- Smart measuring instruments provided with various communication interfaces (e.g. LAN, RS485, USB) and control elements
- SCADA Power Engineering Lab software for the intelligent control and evaluation of "smart grids" using Soft PLC
- SCADA software designed for educational purposes
- Permits investigation of dynamically alternating loads and power generation inside the laboratory
- Intelligent energy management
- Modular integration of renewable energies into a smart grid using protective engineering
- Wind power plant with doubly-fed asynchronous generator (DFIG) and synchronisation to the grid
- Interactive multimedia training course

Renewable Energies



Renewable Energies

The move away from coal, oil and nuclear power to renewable forms of energy is gaining momentum. Today, technology has evolved to a point where solar energy, wind power, hydrogen fuel and biomass can be exploited as environmentally friendly energy sources.

Throughout the world well-qualified technicians and engineers are being sought after to help keep this trend moving forward. Today, technologies are undergoing rapid change. This trend is being compounded by rising expectations in training and education. Lucas-Nülle has developed the appropriate training systems needed to cope with the ever more complex world of training and education.

EPH 2 Advanced Photovoltaics Trainer (PV)



EPH 2 Advanced Photovoltaics Trainer (PV)

The solar trainer enables project work to be carried out with industrial components.

The solar trainer permits realistic simulation of the progression of the sun. Emulators make it possible to carry out the experiments in the laboratory without the sun.

The Interactive Lab Assistant Advanced Photovoltaic multimedia course is designed to convey the theoretical information and practical know-how, and performs the PC-supported evaluation of measurement data.

EPH 2.1 Investigating solar modules



EPH 2.1 Investigating solar modules

Training content:

- Testing the optimum alignment of solar modules
- Recording the characteristics of solar modules
- Investigating the module's response to shadow formation
- Investigating how bypass diodes operate
- Learning about various types of wiring and connection configurations for solar modules

Basic equipment set, consisting of:

Basic equipment set, consisting of:

Pos.	Product name	Bestell-Nr.	Anz.
1	Solar module simulation model, 3-fold, 23V / 2A	CO3208-1A	1

The solar module simulation board puts at your disposal three independent simulations of a solar module allowing you realistic solar module emulations. Higher voltages and stronger currents can be realised by means of series and parallel circuit configurations. For each simulation a separate solar light intensity can be set and a bypass diode added.

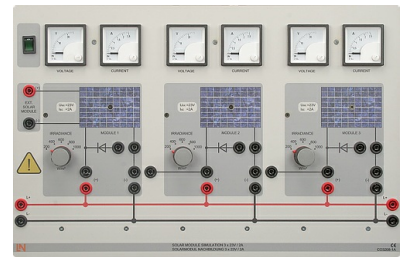

The Solar Module Simulation model is designed with the following features:

- No-load voltage: 3 x 23V
- Maximum short-circuit current: 3 x 2 A
- Light intensity adjustable from 20% ... 100%
- Bypass diode connectable
- Short-circuit proof
- Power: 3 x 40 VA
- Displays: Voltmeter 0 ... 15 V (analog), ammeter 0 ... 2.5 A (analog)
- Operating voltage: 88 ... 264 VAC, 47 ... 63 Hz
- Dimensions: 297 x 456 x 210 mm (HxWxD)
- Weight: 6.8 kg

The solar module rack consists of a polycrystalline solar module and a halogen spotlight as solar simulator. The brightness of the halogen spotlight can be adjusted using a dimmer. Various rooftop angles can be emulated using the tilt adjustment of the solar module allowing these effects on the solar module to be investigated. The halogen spotlight is swivel mounted permitting it to simulate the progression of the sun over a whole day. To be able to emulate the various progressions of the sun over the entire year, the tilt angle of the sun's progression can be adjusted.

Technical data – halogen spotlight:

- Power: 500W
- Power supply: 230 V

Technical data – solar module:

- No-load voltage: 21 V
- Short-circuit current: 650 mA
- Peak power: 10 Wp
- Dimensions: 1200 x 550 x 1100 mm (HxWxD)
- Weight: 10 kg



3 Load unit 1kOhm, 500W

CO3208-1J

1

Load resistor for solar module and solar power units.

The resistor can be used with the following:

- Solar module/simulation for recording characteristics and load resistance
- Solar charge regulator as load resistance
- Inverter as load resistor

The solar load is equipped with the following features:

- Resistor: 0...1 kOhm / 500 W continuously adjustable, with stepped winding
- Current:
 - 0 – 50 Ohm max. 6A
 - 51 – 200 Ohm max 2A
 - 201- 1k Ohm max 0.6A
- Connection terminals: 4 mm safety sockets
- Dimensions: 297 x 228 x 160 mm (HxWxD)
- Weight: 4.3 kg



Media:



Pos.	Product name	Bestell-Nr.	Anz.
4	Interactive Lab Assistant: Photovoltaic systems - Advanced course	SO2800-3H	1

The experiment instructions come in the form of an Interactive Lab Assistant course. This multimedia course is a step-by-step guide through the topic of modern photovoltaic energy systems. The physical fundamentals are conveyed using easy to understand animations. The Interactive Lab Assistant in conjunction with the virtual instruments constitutes a comfortable experimenting environment.

Special features:

- Interactive experiment setups
- Measured values and diagrams can be stored in the experiment instructions per drag and drop
- Virtual instruments can be started directly from the experiment instructions
- Includes questions with feedback and evaluation logic for progress monitoring
- Documents can be printed out for hardcopy of experiment instructions including solutions
- CD-ROM with Labsoft browser, course software and virtual instruments
- Course duration 14 h approx.

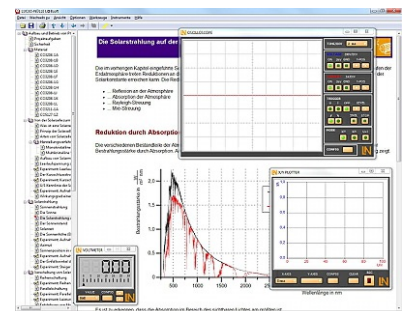

Measuring instruments:

Pos.	Product name	Bestell-Nr.	Anz.
5	Digital/analog multimeter, wattmeter, power-factor incl. software	CO5127-1Z	1

The areas of electrical machines, power electronics and drive technology pose particular problems for measuring instruments. In addition to high-performance overload protection, the acquisition of measurement values must be performed accurately independently of the curve's shape. The universal measuring device has been designed particularly to satisfy these requirements. It can simultaneously replace as many as four different measuring instruments – constituting a current/voltmeter, power and phase-angle meter all in one. The graphic display allows for both student as well demonstration experiments. The VI Starter software included allows for visualisation of measurements on a PC.

- Simultaneous, measurement of voltage and current independent of the curve shape (max. 600 V, 20 A) (measurement of clocked voltages)
- Calculation of active, apparent and reactive power as well as the power factor
- Measurement of the total rms (RMS-AC+DC), AC rms (RMS-AC) and arithmetic mean (AV-AC+DC)
- Impervious to electrical damage up to 20 A/600 V
- Large-scale, high-contrast background-illuminated graphic display (5.7")
- Large-scale display or display of up to 4 measurement values
- Digital or pseudo-analog display
- USB interface
- Internal resistance: current path 10 mΩ, voltage path 10 MΩ
- Voltage ranges: 30, 300, 600 V
- Current ranges: 1, 10, 20 A
- Measurement accuracy: 2%
- Automatic or manual measurement range selection
- Demonstration test instrument for measuring properties of the electricity supply
- Operating voltage: 230V, 50/60Hz
- Dimensions: 297 x 228 x 85 mm (HxBxT)
- Weight: 1.5 kg

The VI Starter software allows all the measurements to be displayed on the PC. Up to 17 different displays can be opened.

- Oscilloscope display of voltage, current and power
- Consumption meter to display power consumed and output
- Data logger for 14 different variables
- Data export for data logger
- Characteristic recorder
- LabVIEW driver and supplied examples

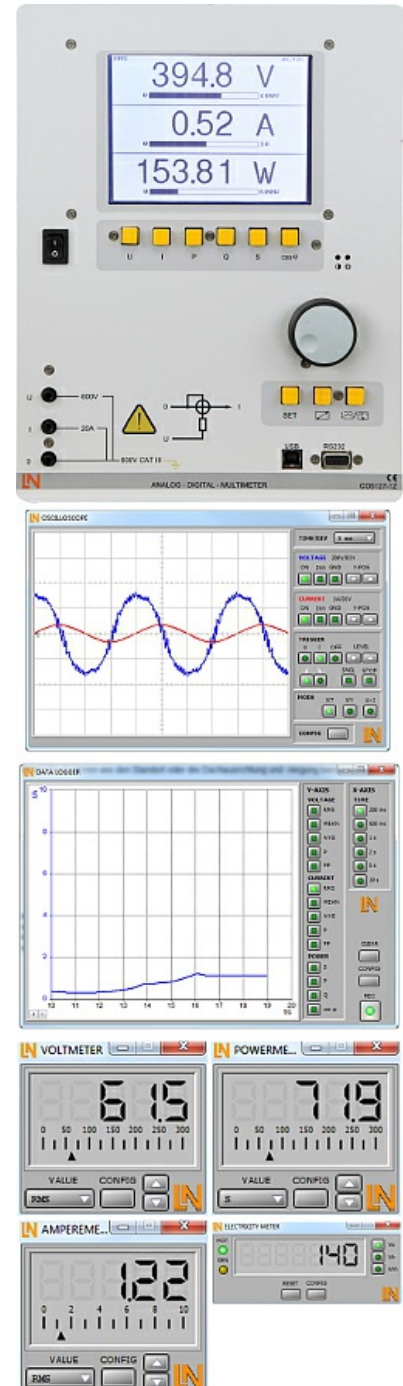

Accessories:

Pos.	Product name	Bestell-Nr.	Anz.
6	Safety connecting plug 4mm with tap (2x), black, 1000V/32A CAT II	SO5126-3R	25
	Moulded insulation		
	<ul style="list-style-type: none">• both sides with touch protection (safety plug + safety sockets), distance 19 mm• transition resistance max. 6 mΩ• rated data: 1000 V / 32 A CAT II• colour black		
7	Safety connecting plug 4mm with tap (2x), red, 1000V/32A CAT II	SO5126-3U	10
	Moulded insulation		
	<ul style="list-style-type: none">• both sides with touch protection (safety plug + safety sockets), distance 19mm• transition resistance max. 6mΩ• rated data: 1000V/32A CAT II• colour red		
8	Safety connecting plug 4mm with tap (2x), blue, 1000V/32A CAT II	SO5126-3V	5
	Moulded insulation		
	<ul style="list-style-type: none">• both sides with touch protection (safety plug + safety sockets), distance 19 mm• transition resistance max. 6 mΩ• rated data: 1000 V/32 A CAT II• colour blue		

9 **Safety connecting plug 4mm with tap (2x), green/yellow, 1000V/32A CAT II**

SO5126-3W

5

Moulded insulation

- both sides with touch protection (safety plug + safety sockets), distance 19 mm
- transition resistance max. 6 mΩ
- rated data: 1000 V / 32 A CAT II
- colour green/yellow



10 **Set of safety measurement cables, 4mm (31 leads)**

SO5148-1L

1

Safety measurement cables with 4mm safety plugs, coloured, PVC insulation, highly flexible

Each set includes the following:

- 6 x 25cm long, black
- 4 x 50cm long, black
- 2 x 100cm long, blue
- 2 x 100cm long, red
- 1 x 100cm long, green/yellow
- 1 x 150cm long, blue
- 1 x 150cm long, green/yellow
- 2 x 150cm long, green
- 4 x 150cm long, brown
- 4 x 150cm long, black
- 4 x 150cm long, grey
- Wire cross section 2.5 mm²
- Capacity/category: 600V CAT II, 32A

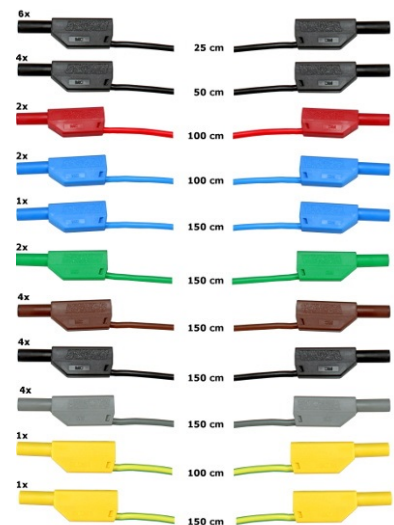

11 **Safety measurement cable (4mm), 50cm/20", red**

SO5126-8K

4

Safety measurement lead with stackable, contact-proof 4mm plugs

- colour: red
- length: 50 cm
- cable cross-section 2,5 mm²
- ratings deliver: 600V CAT II, 32A

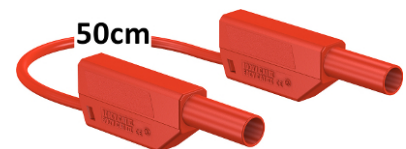

12 **Mobile aluminum experiment stand, 3 levels, power strip with 6 sockets, 49"x28"x79" WxDxH (1250x700x1995mm)**

ST7200-4C

1

High-quality mobile experiment and demonstration trolley from the SybaPro range featuring aluminium table legs and low-level shelf. This trolley is suitable for mounting under-table cabinets and is compatible with all add-ons and extensions in the SybaPro range.

It is supplied with one shelf, an angle bracket for attaching a PC and a cable holder.

Table top + Shelf:

- 30-mm table top made of highly compressed, multi-layer fine chipboard conforming to DIN EN 438-1
- Colour grey, RAL 7035, with 0.8-mm slightly textured laminate coating (Resopal) on both sides, conforming to DIN 16926
- Resistant to many chemicals and reagents including dilute acids and alkalis
- Resistant to heat, e.g. molten solder or heating at specific points such as by soldering tips or cigarette ends
- Frame with solid impact-resistant protective edging made of 3mm thick RAL 7047 coloured plastic
- Coating and adhesive are PVC free
- Power strip with 6 outlet sockets mounted underneath the table top, lead and earthed plug

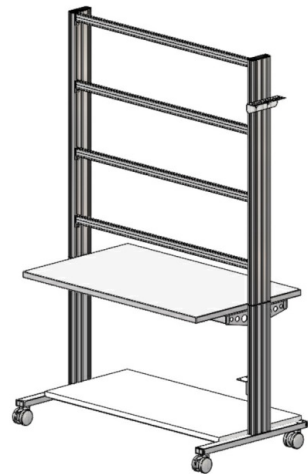

Frame:

- 2 extruded aluminium profiles with multiple grooves 1800 x 120 x 40 mm (WxHxD)
- 8 equally sized grooves in extruded aluminium profiles (3 on each side and 1 each on the front and back)
- Grooves accommodate standard industrial mountings
- 4 H-shaped aluminium profiles, 1150 mm, for 3-layer organisation of DIN A4 panels
- Space for extension of power supply duct
- Base made of rectangular tubing with 4 swiveling double casters, 2 of which have brakes
- Table frame made of tough combination of rectangular tubing around the full perimeter
- Acid-resistant epoxy-resin coating, 80 µm thick (approx.), colour RAL 7047

Cable holder:

- Width 200 mm with 12 cable slots to accommodate 48 x 4-mm safety measurement leads

PC attachment bracket:

- With 3 screw-on rubber stoppers, dimensions 65x65x114 mm approx. (top fixing for PC)

> The height of the cable holder and PC attachment bracket can be adjusted along the aluminium profiles

> For attachment to left or right, fastening materials included

> Acid-resistant epoxy-resin powder coating of thickness 80 µm approx., colour RAL 7047

Dimensions:

- Height of table top 760 mm
- 1250 x 1970 x 700 mm (WxHxD)

The mobile experiment stand is supplied in kit form and needs to be assembled by customers themselves.

13 Monitor holder for flat screen monitor of weight up to 15 kg / 33 lbs VESA 75/100

ST8010-4T

1

Pivoting monitor holder for attachment to aluminium profiles of furniture in the SybaPro range. Allows a monitor to be placed in the optimum position so that work and experiments are less tiring.



- Pivoting arm with two-part joint
- Quick-lock for adjustment to any height on extruded aluminium profile
- VESA fastening 7.5 x 7.5cm
- Includes VESA 75 (7.5x7.5) - VESA 100 (10x10) adapter
- 2 Cable clips
- Adequate carrying capacity 15 kg / 33 lbs
- TFT monitor can be turned parallel to the table edge
- Separation can be adjusted to anywhere between 105 and 480 mm

Additionally included:

Cable management set for installing cables along the profiles of the aluminium lab system furniture in the SybaPro range, consisting of:

- 3 Cross cable binders for front and rear grooves of aluminium profile
- 3 Cross cable binders for side grooves of aluminium profile
- 12 Cable ties
- 4 Aluminium cover profiles for covering and enabling wires to be run along the grooves of an aluminium profile

14 Keyboard adapter for flat screen monitor holders

ST8010-4G

1

Keyboard adapter for use in combination with flat screen monitor holders

- Mounted between monitor and mount for flat screen monitor holder
- Variable 3-level height adjustment via multiple pre-drilled mounting holes
- Two rows of mounting holes for use with equipment meeting VESA 75 and VESA 100 standards
- Keyboard shelf inclined by about 30° for comfortable and ergonomic usability
- Keyboard shelf with 11-mm folded edging to prevent falling, including handle
- Variable 2-level depth attachment for keyboard shelf (252/276 mm)
- Extra-wide keyboard shelf (640 mm) can accommodate a mouse as well
- Depth of keyboard shelf 172 mm
- Includes two cable clips for guiding and bundling cables
- Maximum load 10 kg
- Dimensions (HxWxD) 360 x 640 x 276 mm



15 Protection cover for three-level experiment trolleys

ST8010-9Y

1

Dust cover for three-level experiment trolleys

- For protecting equipment from dust and damp
- For keeping equipment out of sight (the cover must not be transparent, so is therefore opaque)
- Colour: matt dark grey with printed LN logo in orange)
- Material: nylon fabric with polyurethane coating
- High resistant to tearing, impregnated to be washable and waterproof



Recommended learning management software for all LN multimedia courses:

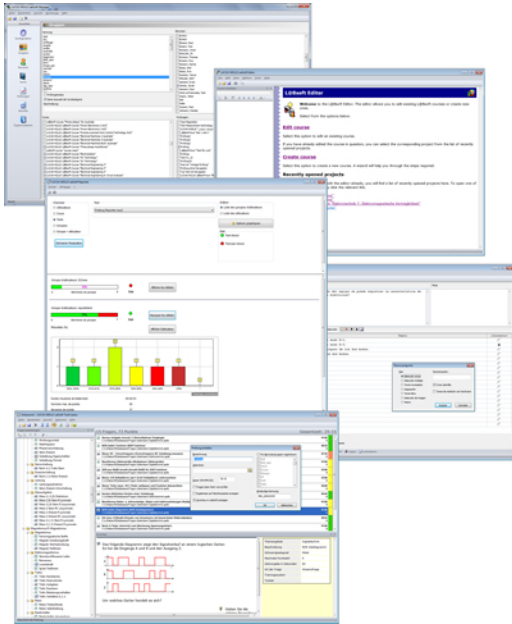

Pos.	Product name	Bestell-Nr.	Anz.
16	LabSoft Classroom Manager 5.0 software suite, single license	SO2001-5A	1

LabSoft Classroom Manager is a comprehensive set of administration software for the UniTrain system and all LabSoft courses. Classroom Manager comprises the following independent program components:

- LabSoft Manager: Administration of students and courses in LabSoft
- LabSoft Reporter: Student reports and statistics
- LabSoft Editor: Creation and editing of courses and tests
- LabSoft Questioner: Creation of questions, measuring exercises and sets of questions for courses and tests
- LabSoft TestCreator: Automatic generation of tests on the basis of sets of questions

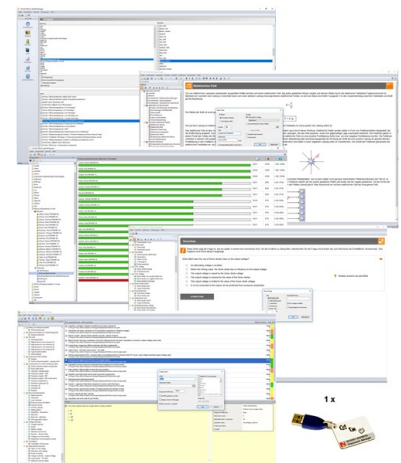

Features:

- Ease of use of all programs thanks to graphical user interface in all component programs
- For use in local area networks or on stand-alone PC
- Ease of installation
- No additional database software required
- Access control via USB dongle
- Available languages: DE, EN, ES, FR, RU, PT, ZH, LO

LabSoft Manager:

- Administration of LabSoft network installation
- Administration of an unlimited number of students and courses in LabSoft

- Addition, deletion and editing of courses and tests in LabSoft
- Addition, deletion and editing of students and student data
- Addition, deletion and editing of student groups (classes)
- Assignment of students to classes
- Activation of team function in LabSoft
- Assignment of courses and tests to students or classes

LabSoft Reporter:

- Electronic monitoring of student progress
- Graphical presentation of progress in courses and tests
- Presentation of student or group results
- Reports on courses, tests, single users or classes
- Summary of results and time
- Export of data to clipboard or file
- Display and printing of tests which have been taken with the candidate's original answers
- Multiple search options for students, classes, courses or tests

LabSoft Editor:

- HTML editor for easy to use editing of LabSoft courses
- Editing of course pages
- Wizard for creation of new courses and course pages
- Automatic inclusion of new courses in an existing LabSoft installation
- Automatic creation of IMS-compatible navigation tree without the need for programming knowledge
- Moving course pages within the navigation tree at the click of a mouse
- Editing in WYSIWYG mode
- HTML view and page preview
- Insertion of graphics, animations and tables
- Insertion of test questions
- Page templates for a variety of page types

LabSoft Questioner:

- Program for creating and editing questions, practical measuring exercises and sets of questions (question files) for electronic evaluation
- Easy creation of exercises and questions for courses and tests
- 7 different types of question: single and multiple choice, missing text, assignment, matrices, arbitrary text, selection of images
- Ability to input meta data (points, time for questions, difficulty, required resources, etc.)
- Easy specification of tolerances for practical measuring exercises
- Changes to the assessment criteria for courses or tests (including after the test has been taken)

LabSoft TestCreator:

- Program for automatically creating electronic tests from sets of questions (question files)
- Automatic and manual selection of questions and measuring exercises
- Filter functions (e.g.: type of question, difficulty) for pre-selection of questions
- Automatic generation of tests according to a set time or number of questions
- Various test options: arbitrary order of questions in a test, immediate display of results after completion
- Automatic registration of tests in LabSoft
- Preview function showing the test as created

Includes:

- CD-ROM with LabSoft Classroom Manager
- 1 USB-dongle for operation of program

System requirements:

- Server or PC with Windows 7, 8, 8.1 or 10
- Microsoft Internet Explorer 9.0 or higher
- Minimum 200 MB free disk space
- 1 free USB-port for USB-dongle

17 Collection of assignments Power Engineering / Renewable Energies

SO2001-6D

1

Collection of electronic assignments questions and measuring exercises for the UniTrain courses on the topic of electrical power engineering and renewable energies. With the help of Labsoft TestCreator, these questions and measuring exercises can easily be assembled into electronic tests. The tests can then be carried out in LabSoft.

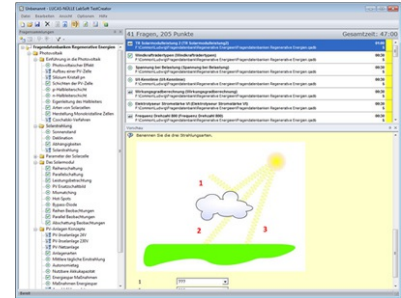

- A total of some 200 questions and measuring exercises for the UniTrain courses on the topics of Photovoltaics, Fuel cell technology, Transient processes in AC and DC networks and the multimedia course Small wind power plant
- About 25% are practical exercises to be carried using the training systems in order to test handling skills and practical abilities
- About 30% are newly assembled questions previously contained in the courses
- It is possible to extend the collection with your own questions and assignments
- Other collections can be imported
- All questions and assignments can be edited
- 6 different types of questions (single choice, multiple choice, missing text, matching, matrix matching and image choice)
- Extensive metadata for all questions and assignments to make it easier to create tests (degree of difficulty, points, topic area, time to complete, type of question, training systems needed for practical exercises)

EPH 2.2 Design of photovoltaic systems in an isolated power network



EPH 2.2 Design of photovoltaic systems in an isolated power network

Training content:

- Installation of PV systems
- Design and testing of a standalone PV system in direct operation
- Design and testing of a standalone PV system in storage operation
- Design and testing of a standalone PV system for the generation of AC voltage compatible with the standard electricity supply

Supplement to basic set, consisting of:

Supplement to basic set, consisting of:

Pos.	Product name	Bestell-Nr.	Anz.
18	Solar charge controller 12/24V, 6A	CO3208-1M	1

The solar charge controller monitors the charge level of the accumulator and protects this against excessive and deep depletion. To charge up the lead accumulator, the charge controller uses the IU charging processes. LEDs provide information regarding the operating and charge status.

The charge regulator is equipped with the following features:

- Automatic 12/24 V switching
- Charge/discharge current: 10 A
- MPP-Tracker
- Gassing regulation
- Connection terminals for:
 - Solar generator
 - Solar accumulator
 - DC load
- Displays: Voltmeter 0 ... 15 V (analog), ammeter 0 ... 10 A (analog)
- Connection terminals: 4 mm safety sockets
- Dimensions: 297 x 228 x 105 mm (HxWxD)
- Weight: 1.1 kg



19 Solar Accumulator 12V, 7Ah

CO3208-1E

1

In modern standalone solar power systems, lead accumulators are used for energy storage. The Solar Accumulator Board is equipped with a maintenance-free and fully-enclosed lead accumulator permitting use at any location.

The solar accumulator is equipped with the following features:

- Voltage: 12 V
- Capacity: 7 Ah
- Re-chargeable
- Overcurrent protection
- Displays: Voltmeter 0 ... 15 V (analog), ammeter -6 ... 6 A (analog)
- Connection terminals: 4 mm safety sockets
- Dimensions: 297 x 228 x 135 mm (HxWxD)
- Weight: 3.7 kg

20 Off-grid inverter 230V, 275VA

CO3208-1F

1

To operate standard commercially available electrical devices used in standalone solar power systems, the generated DC voltage must be converted into AC voltage. The board consists of a commercially available off-grid inverter which generates an output voltage of 230 V AC from an input voltage of 12 V DC. The off-grid inverter is equipped with a deep depletion protection facility with which it can be connected directly to a lead accumulator.

The off-grid inverter is equipped with the following features:

- On/off switch
- LED display of operating status
- Acoustic alarm to signal warnings
- Output voltage: sinusoidal 230V +/- 5%
- Power: 275VA
- Efficiency: 93%
- Safety functions:
 - Cut out for excess battery voltage
 - Over temperature and overload protection
 - Short-circuit protection
 - Pole reversal protection
- Connection terminals: 4 mm safety sockets
- Dimensions: 297 x 228 x 145 mm (HxWxD)
- Weight: 3.1 kg



21 Lamp board 12V

CO3208-1K

1

The lamp board allows for study and comparison of halogen and LED lights. The bulbs are of the same brightness and each can be activated individually. This allows for a variety of power-consumption scenarios to be investigated.

The lamp board has the following features:

- Halogen lamps 25W
- LEDs 2W
- Operating voltage: 12V
- Dimensions: 297 x 114 x 210 mm (HxWxD)
- Weight: 1.2 kg



22 Lamp board 230V

CO3208-1L

1

The lamp board permits the investigation and the comparison of light bulb, energy saving lamp and LED bulb.

All illuminant have the same brightness and can be switched on individually.

Technical Data:

- Light bulb: 25W
- Energy saving lamp: 4W
- LED-bulb 4W
- Operating Voltage: 230V/ 50/60Hz
- 3 sockets E27
- Dimensions: 297 x 114 x 210 mm (HxBxT)
- Weight: 1,8 kg

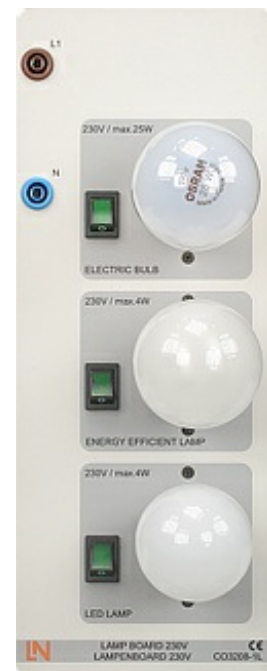

Media:



Pos.	Product name	Bestell-Nr.	Anz.
------	--------------	-------------	------

23 **Interactive Lab Assistant: Photovoltaic systems - Advanced course**

SO2800-3H

1

The experiment instructions come in the form of an Interactive Lab Assistant course. This multimedia course is a step-by-step guide through the topic of modern photovoltaic energy systems. The physical fundamentals are conveyed using easy to understand animations. The Interactive Lab Assistant in conjunction with the virtual instruments constitutes a comfortable experimenting environment.

Special features:

- Interactive experiment setups
- Measured values and diagrams can be stored in the experiment instructions per drag and drop
- Virtual instruments can be started directly from the experiment instructions
- Includes questions with feedback and evaluation logic for progress monitoring
- Documents can be printed out for hardcopy of experiment instructions including solutions
- CD-ROM with Labsoft browser, course software and virtual instruments
- Course duration 14 h approx.

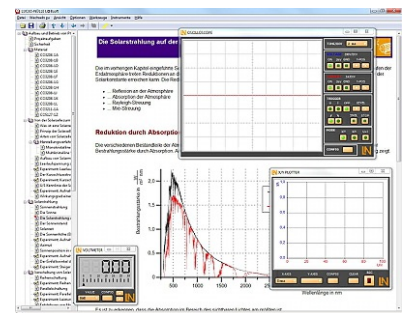

Measuring instruments:

Pos.	Product name	Bestell-Nr.	Anz.
24	Digital/analog multimeter, wattmeter, power-factor incl. software	CO5127-1Z	1

The areas of electrical machines, power electronics and drive technology pose particular problems for measuring instruments. In addition to high-performance overload protection, the acquisition of measurement values must be performed accurately independently of the curve's shape. The universal measuring device has been designed particularly to satisfy these requirements. It can simultaneously replace as many as four different measuring instruments – constituting a current/voltmeter, power and phase-angle meter all in one. The graphic display allows for both student as well demonstration experiments. The VI Starter software included allows for visualisation of measurements on a PC.

- Simultaneous, measurement of voltage and current independent of the curve shape (max. 600 V, 20 A) (measurement of clocked voltages)
- Calculation of active, apparent and reactive power as well as the power factor
- Measurement of the total rms (RMS-AC+DC), AC rms (RMS-AC) and arithmetic mean (AV-AC+DC)
- Impervious to electrical damage up to 20 A/600 V
- Large-scale, high-contrast background-illuminated graphic display (5.7")
- Large-scale display or display of up to 4 measurement values
- Digital or pseudo-analog display
- USB interface
- Internal resistance: current path 10 mΩ, voltage path 10 MΩ
- Voltage ranges: 30, 300, 600 V
- Current ranges: 1, 10, 20 A
- Measurement accuracy: 2%
- Automatic or manual measurement range selection
- Demonstration test instrument for measuring properties of the electricity supply
- Operating voltage: 230V, 50/60Hz
- Dimensions: 297 x 228 x 85 mm (HxBxT)
- Weight: 1.5 kg

The VI Starter software allows all the measurements to be displayed on the PC. Up to 17 different displays can be opened.

- Oscilloscope display of voltage, current and power
- Consumption meter to display power consumed and output
- Data logger for 14 different variables
- Data export for data logger
- Characteristic recorder
- LabVIEW driver and supplied examples

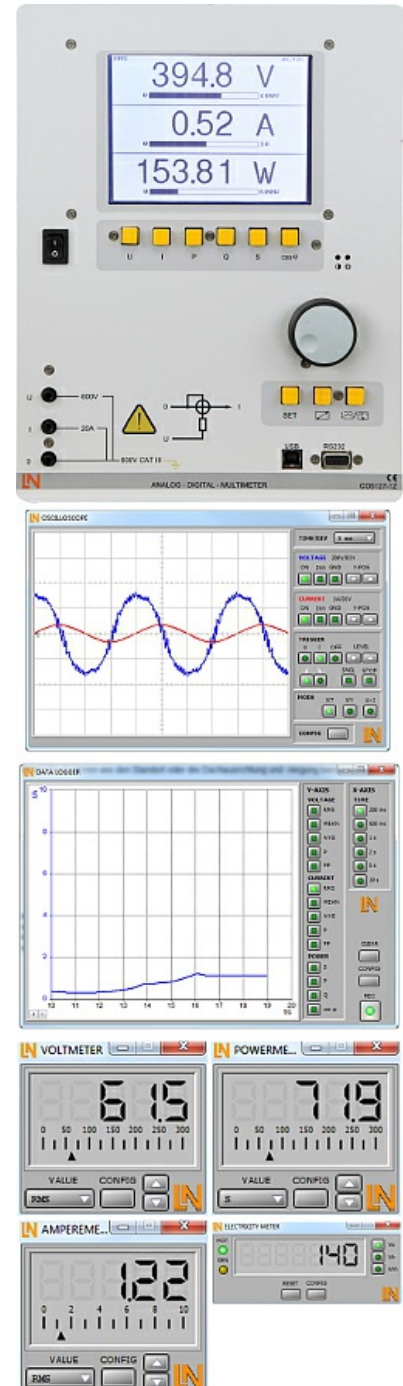

Accessories:

Pos.	Product name	Bestell-Nr.	Anz.
25	Safety connecting plug 4mm with tap (2x), black, 1000V/32A CAT II	SO5126-3R	25
	Moulded insulation		
	<ul style="list-style-type: none">• both sides with touch protection (safety plug + safety sockets), distance 19 mm• transition resistance max. 6 mΩ• rated data: 1000 V / 32 A CAT II• colour black		
26	Safety connecting plug 4mm with tap (2x), red, 1000V/32A CAT II	SO5126-3U	10
	Moulded insulation		
	<ul style="list-style-type: none">• both sides with touch protection (safety plug + safety sockets), distance 19mm• transition resistance max. 6mΩ• rated data: 1000V/32A CAT II• colour red		
27	Safety connecting plug 4mm with tap (2x), blue, 1000V/32A CAT II	SO5126-3V	5
	Moulded insulation		
	<ul style="list-style-type: none">• both sides with touch protection (safety plug + safety sockets), distance 19 mm• transition resistance max. 6 mΩ• rated data: 1000 V/32 A CAT II• colour blue		

28 **Safety connecting plug 4mm with tap (2x), green/yellow, 1000V/32A CAT II**

SO5126-3W

5

Moulded insulation

- both sides with touch protection (safety plug + safety sockets), distance 19 mm
- transition resistance max. 6 mΩ
- rated data: 1000 V / 32 A CAT II
- colour green/yellow



29 **Set of safety measurement cables, 4mm (31 leads)**

SO5148-1L

1

Safety measurement cables with 4mm safety plugs, coloured, PVC insulation, highly flexible

Each set includes the following:

- 6 x 25cm long, black
- 4 x 50cm long, black
- 2 x 100cm long, blue
- 2 x 100cm long, red
- 1 x 100cm long, green/yellow
- 1 x 150cm long, blue
- 1 x 150cm long, green/yellow
- 2 x 150cm long, green
- 4 x 150cm long, brown
- 4 x 150cm long, black
- 4 x 150cm long, grey
- Wire cross section 2.5 mm²
- Capacity/category: 600V CAT II, 32A

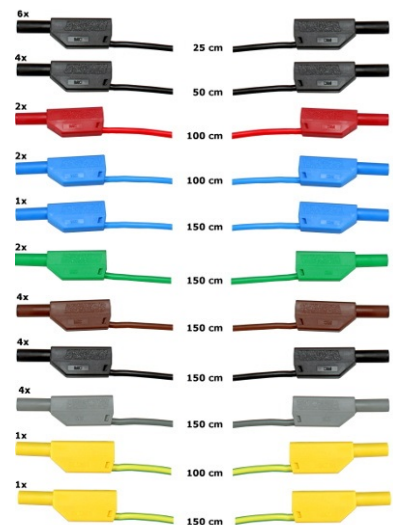

30 **Safety measurement cable (4mm), 50cm/20", red**

SO5126-8K

4

Safety measurement lead with stackable, contact-proof 4mm plugs

- colour: red
- length: 50 cm
- cable cross-section 2,5 mm²
- ratings deliver: 600V CAT II, 32A

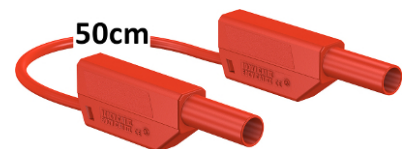

31 **Mobile aluminum experiment stand, 3 levels, power strip with 6 sockets, 49"x28"x79" WxDxH (1250x700x1995mm)**

ST7200-4C

1

High-quality mobile experiment and demonstration trolley from the SybaPro range featuring aluminium table legs and low-level shelf. This trolley is suitable for mounting under-table cabinets and is compatible with all add-ons and extensions in the SybaPro range.

It is supplied with one shelf, an angle bracket for attaching a PC and a cable holder.

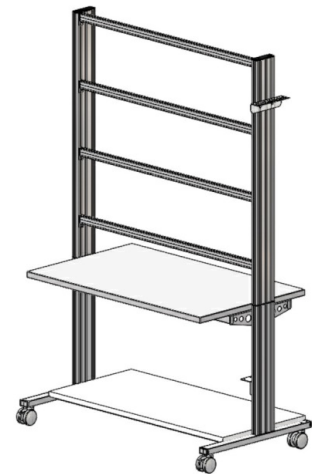

Table top + Shelf:

- 30-mm table top made of highly compressed, multi-layer fine chipboard conforming to DIN EN 438-1
- Colour grey, RAL 7035, with 0.8-mm slightly textured laminate coating (Resopal) on both sides, conforming to DIN 16926
- Resistant to many chemicals and reagents including dilute acids and alkalis
- Resistant to heat, e.g. molten solder or heating at specific points such as by soldering tips or cigarette ends
- Frame with solid impact-resistant protective edging made of 3mm thick RAL 7047 coloured plastic
- Coating and adhesive are PVC free
- Power strip with 6 outlet sockets mounted underneath the table top, lead and earthed plug

Frame:

- 2 extruded aluminium profiles with multiple grooves 1800 x 120 x 40 mm (WxHxD)
- 8 equally sized grooves in extruded aluminium profiles (3 on each side and 1 each on the front and back)
- Grooves accommodate standard industrial mountings
- 4 H-shaped aluminium profiles, 1150 mm, for 3-layer organisation of DIN A4 panels
- Space for extension of power supply duct
- Base made of rectangular tubing with 4 swiveling double casters, 2 of which have brakes
- Table frame made of tough combination of rectangular tubing around the full perimeter
- Acid-resistant epoxy-resin coating, 80 µm thick (approx.), colour RAL 7047

Cable holder:

- Width 200 mm with 12 cable slots to accommodate 48 x 4-mm safety measurement leads

PC attachment bracket:

- With 3 screw-on rubber stoppers, dimensions 65x65x114 mm approx. (top fixing for PC)

> The height of the cable holder and PC attachment bracket can be adjusted along the aluminium profiles

> For attachment to left or right, fastening materials included

> Acid-resistant epoxy-resin powder coating of thickness 80 µm approx., colour RAL 7047

Dimensions:

- Height of table top 760 mm
- 1250 x 1970 x 700 mm (WxHxD)

The mobile experiment stand is supplied in kit form and needs to be assembled by customers themselves.

32 Monitor holder for flat screen monitor of weight up to 15 kg / 33 lbs VESA 75/100

ST8010-4T

1

Pivoting monitor holder for attachment to aluminium profiles of furniture in the SybaPro range. Allows a monitor to be placed in the optimum position so that work and experiments are less tiring.



- Pivoting arm with two-part joint
- Quick-lock for adjustment to any height on extruded aluminium profile
- VESA fastening 7.5 x 7.5cm
- Includes VESA 75 (7.5x7.5) - VESA 100 (10x10) adapter
- 2 Cable clips
- Adequate carrying capacity 15 kg / 33 lbs
- TFT monitor can be turned parallel to the table edge
- Separation can be adjusted to anywhere between 105 and 480 mm

Additionally included:

Cable management set for installing cables along the profiles of the aluminium lab system furniture in the SybaPro range, consisting of:

- 3 Cross cable binders for front and rear grooves of aluminium profile
- 3 Cross cable binders for side grooves of aluminium profile
- 12 Cable ties
- 4 Aluminium cover profiles for covering and enabling wires to be run along the grooves of an aluminium profile

33 Keyboard adapter for flat screen monitor holders

ST8010-4G

1

Keyboard adapter for use in combination with flat screen monitor holders

- Mounted between monitor and mount for flat screen monitor holder
- Variable 3-level height adjustment via multiple pre-drilled mounting holes
- Two rows of mounting holes for use with equipment meeting VESA 75 and VESA 100 standards
- Keyboard shelf inclined by about 30° for comfortable and ergonomic usability
- Keyboard shelf with 11-mm folded edging to prevent falling, including handle
- Variable 2-level depth attachment for keyboard shelf (252/276 mm)
- Extra-wide keyboard shelf (640 mm) can accommodate a mouse as well
- Depth of keyboard shelf 172 mm
- Includes two cable clips for guiding and bundling cables
- Maximum load 10 kg
- Dimensions (HxWxD) 360 x 640 x 276 mm



34 Protection cover for three-level experiment trolleys

ST8010-9Y

1

Dust cover for three-level experiment trolleys

- For protecting equipment from dust and damp
- For keeping equipment out of sight (the cover must not be transparent, so is therefore opaque)
- Colour: matt dark grey with printed LN logo in orange)
- Material: nylon fabric with polyurethane coating
- High resistant to tearing, impregnated to be washable and waterproof



Recommended learning management software for all LN multimedia courses:

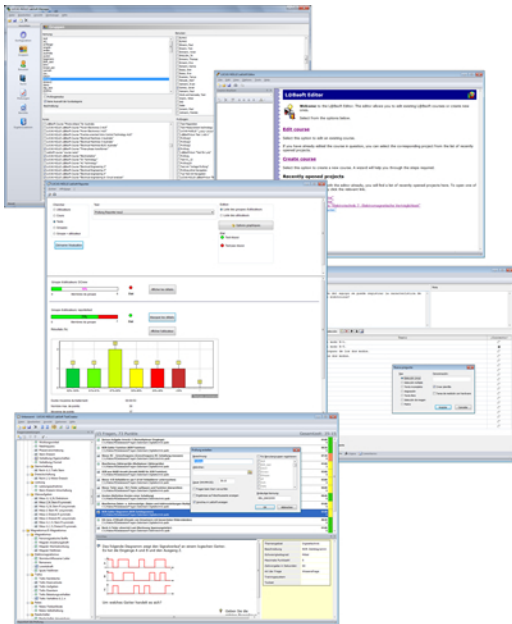

Pos.	Product name	Bestell-Nr.	Anz.
35	LabSoft Classroom Manager 5.0 software suite, single license	SO2001-5A	1

LabSoft Classroom Manager is a comprehensive set of administration software for the UniTrain system and all LabSoft courses. Classroom Manager comprises the following independent program components:

- LabSoft Manager: Administration of students and courses in LabSoft
- LabSoft Reporter: Student reports and statistics
- LabSoft Editor: Creation and editing of courses and tests
- LabSoft Questioner: Creation of questions, measuring exercises and sets of questions for courses and tests
- LabSoft TestCreator: Automatic generation of tests on the basis of sets of questions

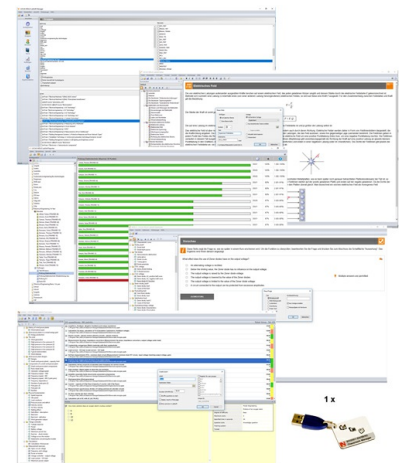

Features:

- Ease of use of all programs thanks to graphical user interface in all component programs
- For use in local area networks or on stand-alone PC
- Ease of installation
- No additional database software required
- Access control via USB dongle
- Available languages: DE, EN, ES, FR, RU, PT, ZH, LO

LabSoft Manager:

- Administration of LabSoft network installation
- Administration of an unlimited number of students and courses in LabSoft

- Addition, deletion and editing of courses and tests in LabSoft
- Addition, deletion and editing of students and student data
- Addition, deletion and editing of student groups (classes)
- Assignment of students to classes
- Activation of team function in LabSoft
- Assignment of courses and tests to students or classes

LabSoft Reporter:

- Electronic monitoring of student progress
- Graphical presentation of progress in courses and tests
- Presentation of student or group results
- Reports on courses, tests, single users or classes
- Summary of results and time
- Export of data to clipboard or file
- Display and printing of tests which have been taken with the candidate's original answers
- Multiple search options for students, classes, courses or tests

LabSoft Editor:

- HTML editor for easy to use editing of LabSoft courses
- Editing of course pages
- Wizard for creation of new courses and course pages
- Automatic inclusion of new courses in an existing LabSoft installation
- Automatic creation of IMS-compatible navigation tree without the need for programming knowledge
- Moving course pages within the navigation tree at the click of a mouse
- Editing in WYSIWYG mode
- HTML view and page preview
- Insertion of graphics, animations and tables
- Insertion of test questions
- Page templates for a variety of page types

LabSoft Questioner:

- Program for creating and editing questions, practical measuring exercises and sets of questions (question files) for electronic evaluation
- Easy creation of exercises and questions for courses and tests
- 7 different types of question: single and multiple choice, missing text, assignment, matrices, arbitrary text, selection of images
- Ability to input meta data (points, time for questions, difficulty, required resources, etc.)
- Easy specification of tolerances for practical measuring exercises
- Changes to the assessment criteria for courses or tests (including after the test has been taken)

LabSoft TestCreator:

- Program for automatically creating electronic tests from sets of questions (question files)
- Automatic and manual selection of questions and measuring exercises
- Filter functions (e.g.: type of question, difficulty) for pre-selection of questions
- Automatic generation of tests according to a set time or number of questions
- Various test options: arbitrary order of questions in a test, immediate display of results after completion
- Automatic registration of tests in LabSoft
- Preview function showing the test as created

Includes:

- CD-ROM with LabSoft Classroom Manager
- 1 USB-dongle for operation of program

System requirements:

- Server or PC with Windows 7, 8, 8.1 or 10
- Microsoft Internet Explorer 9.0 or higher
- Minimum 200 MB free disk space
- 1 free USB-port for USB-dongle

Collection of electronic assignments questions and measuring exercises for the UniTrain courses on the topic of electrical power engineering and renewable energies. With the help of Labsoft TestCreator, these questions and measuring exercises can easily be assembled into electronic tests. The tests can then be carried out in LabSoft.

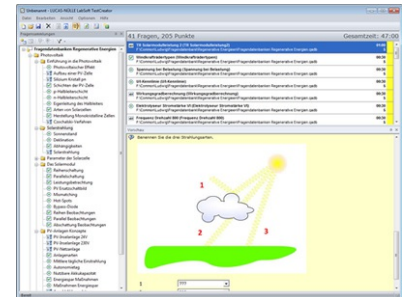

- A total of some 200 questions and measuring exercises for the UniTrain courses on the topics of Photovoltaics, Fuel cell technology, Transient processes in AC and DC networks and the multimedia course Small wind power plant
- About 25% are practical exercises to be carried using the training systems in order to test handling skills and practical abilities
- About 30% are newly assembled questions previously contained in the courses
- It is possible to extend the collection with your own questions and assignments
- Other collections can be imported
- All questions and assignments can be edited
- 6 different types of questions (single choice, multiple choice, missing text, matching, matrix matching and image choice)
- Extensive metadata for all questions and assignments to make it easier to create tests (degree of difficulty, points, topic area, time to complete, type of question, training systems needed for practical exercises)

EPH 2.3 Design of photovoltaic systems for grid-parallel operation

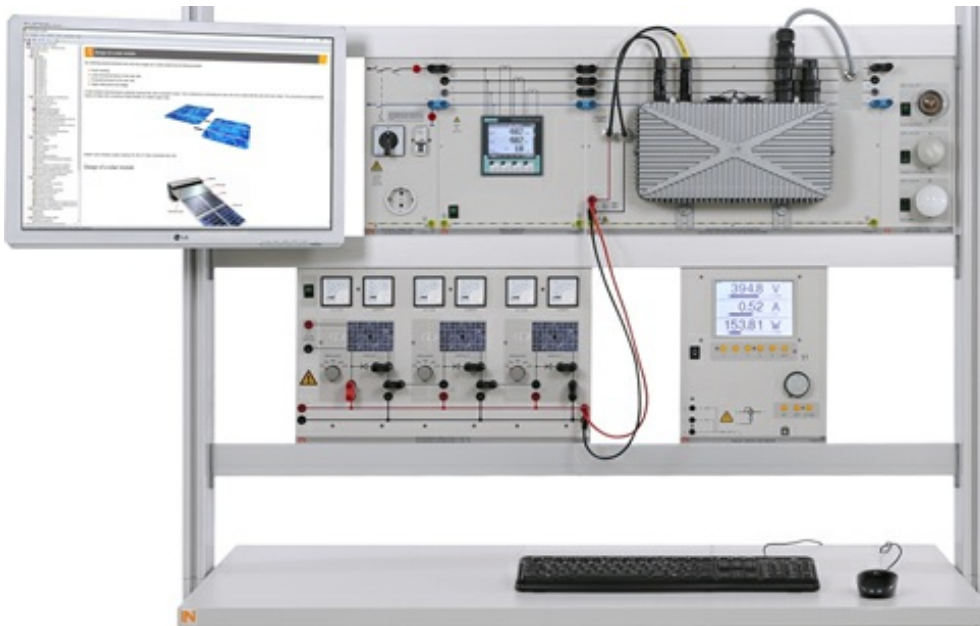

EPH 2.3 Design of photovoltaic systems for grid-parallel operation

Training content:

- Installation of photovoltaic systems
- Design and testing of photovoltaic systems capable of feeding power to the grid
- Measure generated power of a photovoltaic system
- Determine efficiency of the grid-connected inverter
- Investigate response of a photovoltaic system to power outage on the grid

Supplement to basic set, consisting of:

Supplement to basic set, consisting of:

Pos.	Product name	Bestell-Nr.	Anz.
37	Industrial photovoltaic inverter	CO3208-1S	1

Modern solar power systems using grid-connected inverters to feed electric power into the mains. The board consists of an inverter with a built-in monitoring unit. The ENS unit monitors the mains voltage, frequency and impedance and switches the system off in the event of deviations.

The grid-connected inverter is equipped with the following features:

- ENS complies with requirements according to VDE AR-N 4105
- Input voltage range: 40 - 80V
- Output voltage: 230V / 50Hz
- Max. input current: 9 A
- Max. efficiency: 95%
- Output power: 350 W
- Connection terminals: 4 mm safety sockets
- Dimensions: 297 x 456 x 305 mm (HxWxD)
- Weight: 5.8 kg

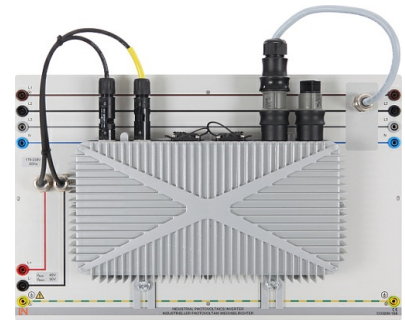

38 Single-phase power supply with switch, circuit breaker and earth-contact socket

CO3211-1A

1

Power supply 230 V/10 A

- Automatic circuit breaker 10 A
- Main switch
- Earth-contact socket
- Output: 4-mm safety sockets
- Dimensions: 297 x 228 x 155 mm. (HxWxD)
- Weight: 0.8 kg



39 Energy monitor

CO3208-1T

1

The digital energy monitor is a three-phase AC electricity meter which makes it possible to simply measure the energy output by a solar electricity generator or energy consumed by an electrical appliance.

The following requirements are to be fulfilled:

The energy monitor must include the following features:

- Three-phase measurement of current and voltage, 3x400 V/5 A
- Measurement of phase voltages, line-to-line voltages, currents
- Determination of apparent, active and reactive power
- Determination of active and reactive energy
- Determination of frequency and power factor
- Large, high-contrast background-lit graphic display

Max. measurement values:

- Voltage: L-L: 576 V
- Current: 5 A
- Precision class 1
- Operating voltage: 110V-230 V, 50/60 Hz
- Dimensions: 297 x 228 x 140 mm (HxWxD)
- Weight: 2 kg

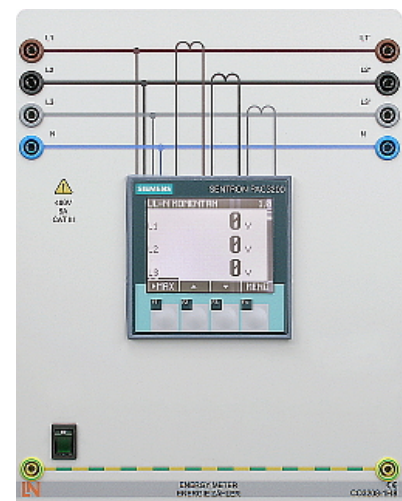

Media:



Pos.	Product name	Bestell-Nr.	Anz.
40	Interactive Lab Assistant: Photovoltaic systems - Advanced course	SO2800-3H	1

The experiment instructions come in the form of an Interactive Lab Assistant course. This multimedia course is a step-by-step guide through the topic of modern photovoltaic energy systems. The physical fundamentals are conveyed using easy to understand animations. The Interactive Lab Assistant in conjunction with the virtual instruments constitutes a comfortable experimenting environment.

Special features:

- Interactive experiment setups
- Measured values and diagrams can be stored in the experiment instructions per drag and drop
- Virtual instruments can be started directly from the experiment instructions
- Includes questions with feedback and evaluation logic for progress monitoring
- Documents can be printed out for hardcopy of experiment instructions including solutions
- CD-ROM with Labsoft browser, course software and virtual instruments
- Course duration 14 h approx.

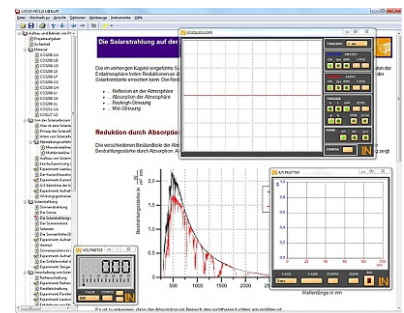

Measuring instruments:

Pos.	Product name	Bestell-Nr.	Anz.
41	Digital/analog multimeter, wattmeter, power-factor incl. software	CO5127-1Z	1

The areas of electrical machines, power electronics and drive technology pose particular problems for measuring instruments. In addition to high-performance overload protection, the acquisition of measurement values must be performed accurately independently of the curve's shape. The universal measuring device has been designed particularly to satisfy these requirements. It can simultaneously replace as many as four different measuring instruments – constituting a current/voltmeter, power and phase-angle meter all in one. The graphic display allows for both student as well demonstration experiments. The VI Starter software included allows for visualisation of measurements on a PC.

- Simultaneous, measurement of voltage and current independent of the curve shape (max. 600 V, 20 A) (measurement of clocked voltages)
- Calculation of active, apparent and reactive power as well as the power factor
- Measurement of the total rms (RMS-AC+DC), AC rms (RMS-AC) and arithmetic mean (AV-AC+DC)
- Impervious to electrical damage up to 20 A/600 V
- Large-scale, high-contrast background-illuminated graphic display (5.7")
- Large-scale display or display of up to 4 measurement values
- Digital or pseudo-analog display
- USB interface
- Internal resistance: current path 10 mΩ, voltage path 10 MΩ
- Voltage ranges: 30, 300, 600 V
- Current ranges: 1, 10, 20 A
- Measurement accuracy: 2%
- Automatic or manual measurement range selection
- Demonstration test instrument for measuring properties of the electricity supply
- Operating voltage: 230V, 50/60Hz
- Dimensions: 297 x 228 x 85 mm (HxBxT)
- Weight: 1.5 kg

The VI Starter software allows all the measurements to be displayed on the PC. Up to 17 different displays can be opened.

- Oscilloscope display of voltage, current and power
- Consumption meter to display power consumed and output
- Data logger for 14 different variables
- Data export for data logger
- Characteristic recorder
- LabVIEW driver and supplied examples

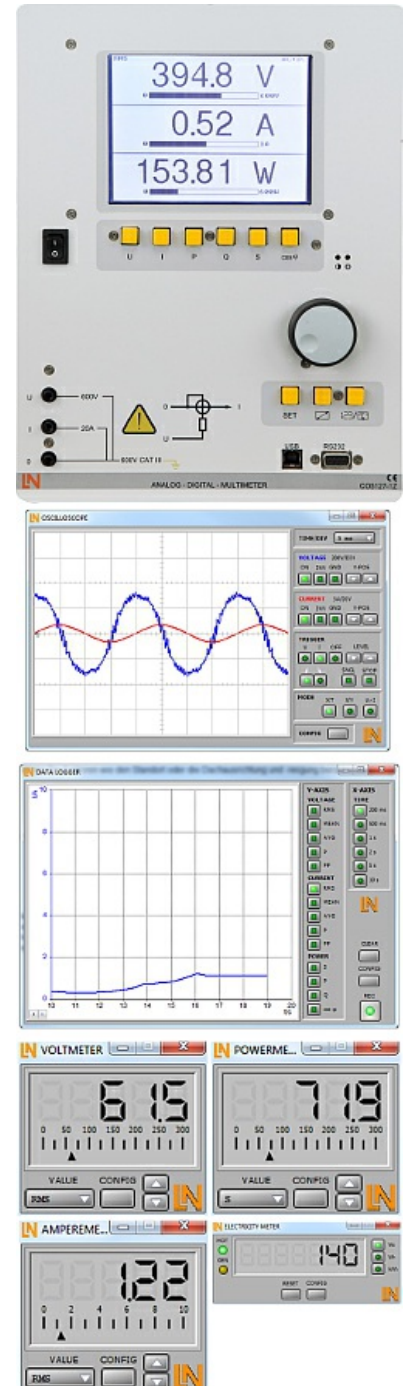

Accessories:

Pos.	Product name	Bestell-Nr.	Anz.
42	Safety connecting plug 4mm with tap (2x), black, 1000V/32A CAT II	SO5126-3R	25
	Moulded insulation		
	<ul style="list-style-type: none">• both sides with touch protection (safety plug + safety sockets), distance 19 mm• transition resistance max. 6 mΩ• rated data: 1000 V / 32 A CAT II• colour black		
43	Safety connecting plug 4mm with tap (2x), red, 1000V/32A CAT II	SO5126-3U	10
	Moulded insulation		
	<ul style="list-style-type: none">• both sides with touch protection (safety plug + safety sockets), distance 19mm• transition resistance max. 6mΩ• rated data: 1000V/32A CAT II• colour red		
44	Safety connecting plug 4mm with tap (2x), blue, 1000V/32A CAT II	SO5126-3V	5
	Moulded insulation		
	<ul style="list-style-type: none">• both sides with touch protection (safety plug + safety sockets), distance 19 mm• transition resistance max. 6 mΩ• rated data: 1000 V/32 A CAT II• colour blue		

45 **Safety connecting plug 4mm with tap (2x), green/yellow, 1000V/32A CAT II**

SO5126-3W

5

Moulded insulation

- both sides with touch protection (safety plug + safety sockets), distance 19 mm
- transition resistance max. 6 mΩ
- rated data: 1000 V / 32 A CAT II
- colour green/yellow



46 **Set of safety measurement cables, 4mm (31 leads)**

SO5148-1L

1

Safety measurement cables with 4mm safety plugs, coloured, PVC insulation, highly flexible

Each set includes the following:

- 6 x 25cm long, black
- 4 x 50cm long, black
- 2 x 100cm long, blue
- 2 x 100cm long, red
- 1 x 100cm long, green/yellow
- 1 x 150cm long, blue
- 1 x 150cm long, green/yellow
- 2 x 150cm long, green
- 4 x 150cm long, brown
- 4 x 150cm long, black
- 4 x 150cm long, grey
- Wire cross section 2.5 mm²
- Capacity/category: 600V CAT II, 32A

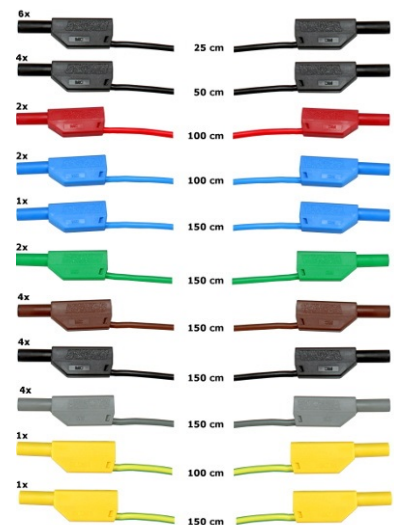

47 **Safety measurement cable (4mm), 50cm/20", red**

SO5126-8K

4

Safety measurement lead with stackable, contact-proof 4mm plugs

- colour: red
- length: 50 cm
- cable cross-section 2,5 mm²
- ratings deliver: 600V CAT II, 32A

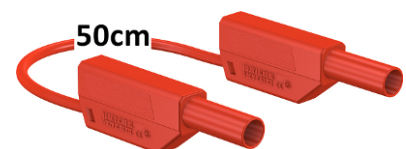

48 **Mobile aluminum experiment stand, 3 levels, power strip with 6 sockets, 49"x28"x79" WxDxH (1250x700x1995mm)**

ST7200-4C

1

High-quality mobile experiment and demonstration trolley from the SybaPro range featuring aluminium table legs and low-level shelf. This trolley is suitable for mounting under-table cabinets and is compatible with all add-ons and extensions in the SybaPro range.

It is supplied with one shelf, an angle bracket for attaching a PC and a cable holder.

Table top + Shelf:

- 30-mm table top made of highly compressed, multi-layer fine chipboard conforming to DIN EN 438-1
- Colour grey, RAL 7035, with 0.8-mm slightly textured laminate coating (Resopal) on both sides, conforming to DIN 16926
- Resistant to many chemicals and reagents including dilute acids and alkalis
- Resistant to heat, e.g. molten solder or heating at specific points such as by soldering tips or cigarette ends
- Frame with solid impact-resistant protective edging made of 3mm thick RAL 7047 coloured plastic
- Coating and adhesive are PVC free
- Power strip with 6 outlet sockets mounted underneath the table top, lead and earthed plug

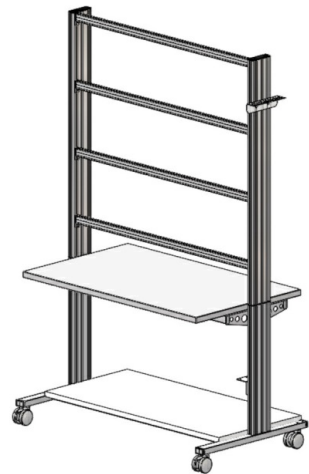

Frame:

- 2 extruded aluminium profiles with multiple grooves 1800 x 120 x 40 mm (WxHxD)
- 8 equally sized grooves in extruded aluminium profiles (3 on each side and 1 each on the front and back)
- Grooves accommodate standard industrial mountings
- 4 H-shaped aluminium profiles, 1150 mm, for 3-layer organisation of DIN A4 panels
- Space for extension of power supply duct
- Base made of rectangular tubing with 4 swiveling double casters, 2 of which have brakes
- Table frame made of tough combination of rectangular tubing around the full perimeter
- Acid-resistant epoxy-resin coating, 80 µm thick (approx.), colour RAL 7047

Cable holder:

- Width 200 mm with 12 cable slots to accommodate 48 x 4-mm safety measurement leads

PC attachment bracket:

- With 3 screw-on rubber stoppers, dimensions 65x65x114 mm approx. (top fixing for PC)

> The height of the cable holder and PC attachment bracket can be adjusted along the aluminium profiles

> For attachment to left or right, fastening materials included

> Acid-resistant epoxy-resin powder coating of thickness 80 µm approx., colour RAL 7047

Dimensions:

- Height of table top 760 mm
- 1250 x 1970 x 700 mm (WxHxD)

The mobile experiment stand is supplied in kit form and needs to be assembled by customers themselves.

49 **Monitor holder for flat screen monitor of weight up to 15 kg / 33 lbs VESA 75/100**

ST8010-4T

1

Pivoting monitor holder for attachment to aluminium profiles of furniture in the SybaPro range. Allows a monitor to be placed in the optimum position so that work and experiments are less tiring.



- Pivoting arm with two-part joint
- Quick-lock for adjustment to any height on extruded aluminium profile
- VESA fastening 7.5 x 7.5cm
- Includes VESA 75 (7.5x7.5) - VESA 100 (10x10) adapter
- 2 Cable clips
- Adequate carrying capacity 15 kg / 33 lbs
- TFT monitor can be turned parallel to the table edge
- Separation can be adjusted to anywhere between 105 and 480 mm

Additionally included:

Cable management set for installing cables along the profiles of the aluminium lab system furniture in the SybaPro range, consisting of:

- 3 Cross cable binders for front and rear grooves of aluminium profile
- 3 Cross cable binders for side grooves of aluminium profile
- 12 Cable ties
- 4 Aluminium cover profiles for covering and enabling wires to be run along the grooves of an aluminium profile

50 Keyboard adapter for flat screen monitor holders

ST8010-4G

1

Keyboard adapter for use in combination with flat screen monitor holders

- Mounted between monitor and mount for flat screen monitor holder
- Variable 3-level height adjustment via multiple pre-drilled mounting holes
- Two rows of mounting holes for use with equipment meeting VESA 75 and VESA 100 standards
- Keyboard shelf inclined by about 30° for comfortable and ergonomic usability
- Keyboard shelf with 11-mm folded edging to prevent falling, including handle
- Variable 2-level depth attachment for keyboard shelf (252/276 mm)
- Extra-wide keyboard shelf (640 mm) can accommodate a mouse as well
- Depth of keyboard shelf 172 mm
- Includes two cable clips for guiding and bundling cables
- Maximum load 10 kg
- Dimensions (HxWxD) 360 x 640 x 276 mm



51 Protection cover for three-level experiment trolleys

ST8010-9Y

1

Dust cover for three-level experiment trolleys

- For protecting equipment from dust and damp
- For keeping equipment out of sight (the cover must not be transparent, so is therefore opaque)
- Colour: matt dark grey with printed LN logo in orange)
- Material: nylon fabric with polyurethane coating
- High resistant to tearing, impregnated to be washable and waterproof



Recommended learning management software for all LN multimedia courses:

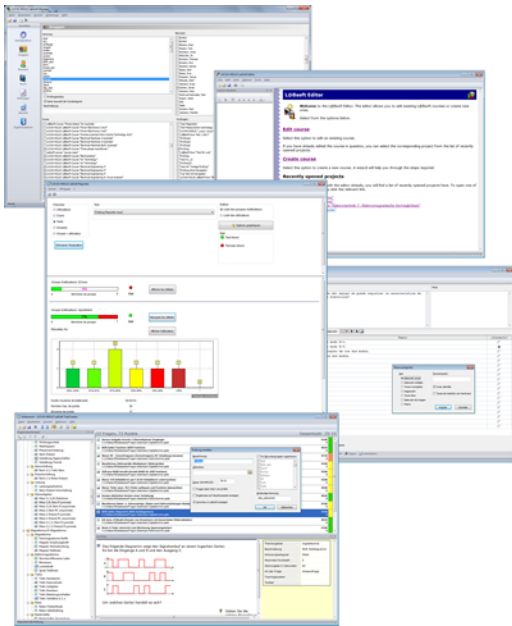

Pos.	Product name	Bestell-Nr.	Anz.
52	LabSoft Classroom Manager 5.0 software suite, single license	SO2001-5A	1

LabSoft Classroom Manager is a comprehensive set of administration software for the UniTrain system and all LabSoft courses. Classroom Manager comprises the following independent program components:

- LabSoft Manager: Administration of students and courses in LabSoft
- LabSoft Reporter: Student reports and statistics
- LabSoft Editor: Creation and editing of courses and tests
- LabSoft Questioner: Creation of questions, measuring exercises and sets of questions for courses and tests
- LabSoft TestCreator: Automatic generation of tests on the basis of sets of questions

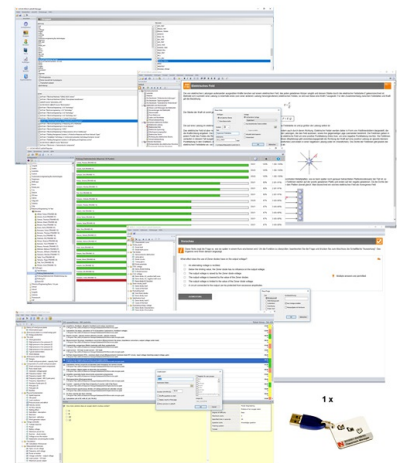

Features:

- Ease of use of all programs thanks to graphical user interface in all component programs
- For use in local area networks or on stand-alone PC
- Ease of installation
- No additional database software required
- Access control via USB dongle
- Available languages: DE, EN, ES, FR, RU, PT, ZH, LO

LabSoft Manager:

- Administration of LabSoft network installation
- Administration of an unlimited number of students and courses in LabSoft

- Addition, deletion and editing of courses and tests in LabSoft
- Addition, deletion and editing of students and student data
- Addition, deletion and editing of student groups (classes)
- Assignment of students to classes
- Activation of team function in LabSoft
- Assignment of courses and tests to students or classes

LabSoft Reporter:

- Electronic monitoring of student progress
- Graphical presentation of progress in courses and tests
- Presentation of student or group results
- Reports on courses, tests, single users or classes
- Summary of results and time
- Export of data to clipboard or file
- Display and printing of tests which have been taken with the candidate's original answers
- Multiple search options for students, classes, courses or tests

LabSoft Editor:

- HTML editor for easy to use editing of LabSoft courses
- Editing of course pages
- Wizard for creation of new courses and course pages
- Automatic inclusion of new courses in an existing LabSoft installation
- Automatic creation of IMS-compatible navigation tree without the need for programming knowledge
- Moving course pages within the navigation tree at the click of a mouse
- Editing in WYSIWYG mode
- HTML view and page preview
- Insertion of graphics, animations and tables
- Insertion of test questions
- Page templates for a variety of page types

LabSoft Questioner:

- Program for creating and editing questions, practical measuring exercises and sets of questions (question files) for electronic evaluation
- Easy creation of exercises and questions for courses and tests
- 7 different types of question: single and multiple choice, missing text, assignment, matrices, arbitrary text, selection of images
- Ability to input meta data (points, time for questions, difficulty, required resources, etc.)
- Easy specification of tolerances for practical measuring exercises
- Changes to the assessment criteria for courses or tests (including after the test has been taken)

LabSoft TestCreator:

- Program for automatically creating electronic tests from sets of questions (question files)
- Automatic and manual selection of questions and measuring exercises
- Filter functions (e.g.: type of question, difficulty) for pre-selection of questions
- Automatic generation of tests according to a set time or number of questions
- Various test options: arbitrary order of questions in a test, immediate display of results after completion
- Automatic registration of tests in LabSoft
- Preview function showing the test as created

Includes:

- CD-ROM with LabSoft Classroom Manager
- 1 USB-dongle for operation of program

System requirements:

- Server or PC with Windows 7, 8, 8.1 or 10
- Microsoft Internet Explorer 9.0 or higher
- Minimum 200 MB free disk space
- 1 free USB-port for USB-dongle

Collection of electronic assignments questions and measuring exercises for the UniTrain courses on the topic of electrical power engineering and renewable energies. With the help of Labsoft TestCreator, these questions and measuring exercises can easily be assembled into electronic tests. The tests can then be carried out in LabSoft.

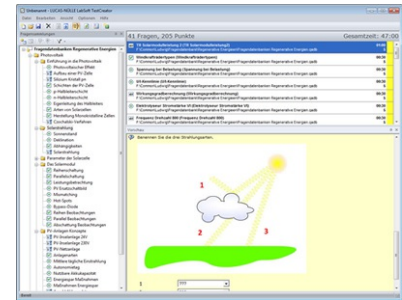

- A total of some 200 questions and measuring exercises for the UniTrain courses on the topics of Photovoltaics, Fuel cell technology, Transient processes in AC and DC networks and the multimedia course Small wind power plant
- About 25% are practical exercises to be carried using the training systems in order to test handling skills and practical abilities
- About 30% are newly assembled questions previously contained in the courses
- It is possible to extend the collection with your own questions and assignments
- Other collections can be imported
- All questions and assignments can be edited
- 6 different types of questions (single choice, multiple choice, missing text, matching, matrix matching and image choice)
- Extensive metadata for all questions and assignments to make it easier to create tests (degree of difficulty, points, topic area, time to complete, type of question, training systems needed for practical exercises)

EPH 2.4 Solar pumps



EPH 2.4 Solar pumps

Training content:

- Differences between various solar pump systems
- Planning of solar pump systems
- Flow-rate measurement
- Daily volume measurement
- Investigating response at different degrees of irradiance and shadowing
- Investigating with different daily irradiation periods
- Recording characteristics and calculating the efficiency of the pump and overall system

Supplement to basic set, consisting of:

Supplement to basic set, consisting of:

Pos.	Product name	Bestell-Nr.	Anz.
54	BLDC solar pump system with integrated measuring instrument, on a trolley	CO3208-6M	1

Realistic simulation of a solar pump system with an industrial pump which can be connected to real solar modules or a solar module replica.

- Large lower basin, approx. 40 l
- Industrial pump system with pump and controller
- Highly efficient pump with brushless DC motor, power approx. 300 VA
- Controller with MPP control of solar power, BLDC control, Bluetooth interface for parameterization, displays for operating / malfunction indication
- Protection against reverse polarity, overload and overheating
- Level sensor to protect the pump
- Integrated industrial pressure sensor, 4-20mA
- 1kΩ resistor as 4mm plug-in module with gold-plated contacts
- Combination of simulation and real experiments
- Relay for control of DC power supply and the upper tank's sensor
- Relay control, manually or via SCADA software
- SCADA model included, with the following functions:
 - Visualization of values
 - Automatic control
 - Simulation of realistic situations, sunrise / sunset and the upper basin's volume
- Integrated three-phase measuring device
 - Measurement of three-phase currents and voltages, 3 x 400V / 5A
 - Measurement of phase voltages, linked voltages and currents
 - Determination of apparent/active/reactive power, active/reactive/apparent work, frequency and distortion factors for current and voltage
 - Large, high-contrast backlit graphic display; analysis of harmonic vibrations
 - Representation in tables, charts and vector diagrams
 - Ethernet interface with integration in SCADA
- Front panel with photo-realistic colour printing
- Integrated mobile stand with 4 steerable double rollers, 2 of them braked
- Side parts made of extruded aluminium profile with multi-groove profiling for attaching various accessories
- Dimensions: Approx. 600 x 1700 x 900 mm
- Weight: 20 kg



55 **Patch cable Cat5E 1x 1m yellow, 2x 2m yellow**

LM9057

2

- 1x 1m yellow
- 2x 2m yellow



56 **USB Network Adapter 10/100 BaseTX RJ45**

LM9056

1

USB-Ethernet adapter provides simple network access without having to install expansion card. The adapter is thus well-suited especially for cases where there are no more slots available in the PC or the housing should not be opened. This adapter is also an alternative for notebooks: instead of a PC card with an Ethernet port the adapter offers a universal connection option for all PCs with USB interface.

- USB 2.0 high-speed device
- Downward compatible with USB 1.1 and 1.0 Host controllers
- Compatible with IEEE 802.3u, 10/100 Base-T and TX
- Supports both full and half-duplex mode on Ethernet interface
- Operating systems: Windows ME/200/XP/Vista,7 (32+64 Bit), Linux, Mac OS 10.x



Software:

Pos.	Product name	Bestell-Nr.	Anz.
57	Software SCADA Viewer	SO4001-3H	1

The 'SCADA Viewer' is a software program used for the control and monitoring of power engineering systems. With the software it is possible to display all measured values and operating states inside the system in real time on the existing measuring instruments. Important parameters and signals can be controlled by the software.

The measured values and operating states of the equipment can be selected, recorded and plotted over time, evaluated and then exported.

Using the 'SCADA Viewer' projects in power engineering are not only made transparent but readable.

Software functions:

- Display of measured values and operating states in real time
- Plotting of measured values over time in diagrams
- Processing, analyzing and exporting of diagrams
- The SCADA viewer contains more than 20 predefined projects
- Many projects designed with the SCADA designer can be individually expanded at will

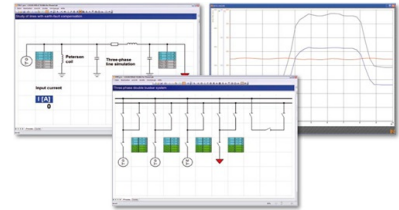

Media:



Pos.	Product name	Bestell-Nr.	Anz.
58	Interactive Lab Assistant: Photovoltaic systems - Advanced course	SO2800-3H	1

The experiment instructions come in the form of an Interactive Lab Assistant course. This multimedia course is a step-by-step guide through the topic of modern photovoltaic energy systems. The physical fundamentals are conveyed using easy to understand animations. The Interactive Lab Assistant in conjunction with the virtual instruments constitutes a comfortable experimenting environment.

Special features:

- Interactive experiment setups
- Measured values and diagrams can be stored in the experiment instructions per drag and drop
- Virtual instruments can be started directly from the experiment instructions
- Includes questions with feedback and evaluation logic for progress monitoring
- Documents can be printed out for hardcopy of experiment instructions including solutions
- CD-ROM with Labsoft browser, course software and virtual instruments
- Course duration 14 h approx.

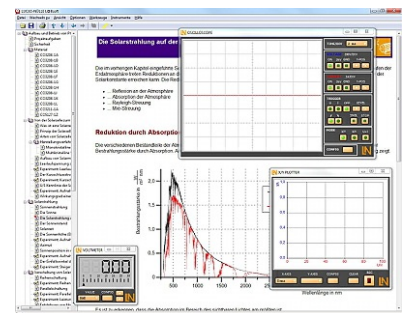

Measuring instruments:

Pos.	Product name	Bestell-Nr.	Anz.
59	Digital/analog multimeter, wattmeter, power-factor incl. software	CO5127-1Z	1

The areas of electrical machines, power electronics and drive technology pose particular problems for measuring instruments. In addition to high-performance overload protection, the acquisition of measurement values must be performed accurately independently of the curve's shape. The universal measuring device has been designed particularly to satisfy these requirements. It can simultaneously replace as many as four different measuring instruments – constituting a current/voltmeter, power and phase-angle meter all in one. The graphic display allows for both student as well demonstration experiments. The VI Starter software included allows for visualisation of measurements on a PC.

- Simultaneous, measurement of voltage and current independent of the curve shape (max. 600 V, 20 A) (measurement of clocked voltages)
- Calculation of active, apparent and reactive power as well as the power factor
- Measurement of the total rms (RMS-AC+DC), AC rms (RMS-AC) and arithmetic mean (AV-AC+DC)
- Impervious to electrical damage up to 20 A/600 V
- Large-scale, high-contrast background-illuminated graphic display (5.7")
- Large-scale display or display of up to 4 measurement values
- Digital or pseudo-analog display
- USB interface
- Internal resistance: current path 10 mΩ, voltage path 10 MΩ
- Voltage ranges: 30, 300, 600 V
- Current ranges: 1, 10, 20 A
- Measurement accuracy: 2%
- Automatic or manual measurement range selection
- Demonstration test instrument for measuring properties of the electricity supply
- Operating voltage: 230V, 50/60Hz
- Dimensions: 297 x 228 x 85 mm (HxBxT)
- Weight: 1.5 kg

The VI Starter software allows all the measurements to be displayed on the PC. Up to 17 different displays can be opened.

- Oscilloscope display of voltage, current and power
- Consumption meter to display power consumed and output
- Data logger for 14 different variables
- Data export for data logger
- Characteristic recorder
- LabVIEW driver and supplied examples

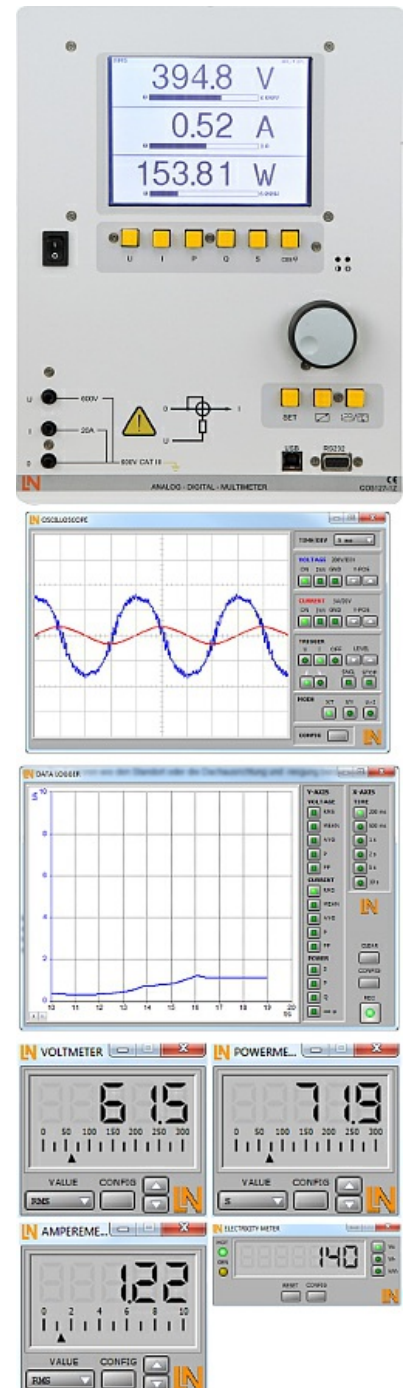

Accessories:

Pos.	Product name	Bestell-Nr.	Anz.
60	Safety connecting plug 4mm with tap (2x), black, 1000V/32A CAT II	SO5126-3R	25
	Moulded insulation		
	<ul style="list-style-type: none">• both sides with touch protection (safety plug + safety sockets), distance 19 mm• transition resistance max. 6 mΩ• rated data: 1000 V / 32 A CAT II• colour black		
61	Safety connecting plug 4mm with tap (2x), red, 1000V/32A CAT II	SO5126-3U	10
	Moulded insulation		
	<ul style="list-style-type: none">• both sides with touch protection (safety plug + safety sockets), distance 19mm• transition resistance max. 6mΩ• rated data: 1000V/32A CAT II• colour red		
62	Safety connecting plug 4mm with tap (2x), blue, 1000V/32A CAT II	SO5126-3V	5
	Moulded insulation		
	<ul style="list-style-type: none">• both sides with touch protection (safety plug + safety sockets), distance 19 mm• transition resistance max. 6 mΩ• rated data: 1000 V/32 A CAT II• colour blue		

63 **Safety connecting plug 4mm with tap (2x), green/yellow, 1000V/32A CAT II**

SO5126-3W

5

Moulded insulation

- both sides with touch protection (safety plug + safety sockets), distance 19 mm
- transition resistance max. 6 mΩ
- rated data: 1000 V / 32 A CAT II
- colour green/yellow



64 **Set of safety measurement cables, 4mm (31 leads)**

SO5148-1L

1

Safety measurement cables with 4mm safety plugs, coloured, PVC insulation, highly flexible

Each set includes the following:

- 6 x 25cm long, black
- 4 x 50cm long, black
- 2 x 100cm long, blue
- 2 x 100cm long, red
- 1 x 100cm long, green/yellow
- 1 x 150cm long, blue
- 1 x 150cm long, green/yellow
- 2 x 150cm long, green
- 4 x 150cm long, brown
- 4 x 150cm long, black
- 4 x 150cm long, grey
- Wire cross section 2.5 mm²
- Capacity/category: 600V CAT II, 32A

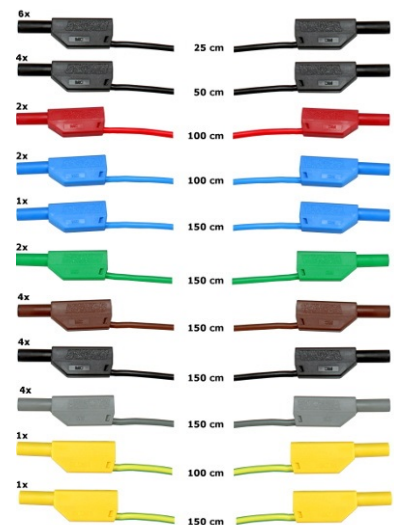

65 **Safety measurement cable (4mm), 50cm/20", red**

SO5126-8K

4

Safety measurement lead with stackable, contact-proof 4mm plugs

- colour: red
- length: 50 cm
- cable cross-section 2,5 mm²
- ratings deliver: 600V CAT II, 32A

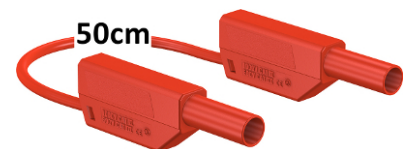

66 **Mobile aluminum experiment stand, 3 levels, power strip with 6 sockets, 49"x28"x79" WxDxH (1250x700x1995mm)**

ST7200-4C

1

High-quality mobile experiment and demonstration trolley from the SybaPro range featuring aluminium table legs and low-level shelf. This trolley is suitable for mounting under-table cabinets and is compatible with all add-ons and extensions in the SybaPro range.

It is supplied with one shelf, an angle bracket for attaching a PC and a cable holder.

Table top + Shelf:

- 30-mm table top made of highly compressed, multi-layer fine chipboard conforming to DIN EN 438-1
- Colour grey, RAL 7035, with 0.8-mm slightly textured laminate coating (Resopal) on both sides, conforming to DIN 16926
- Resistant to many chemicals and reagents including dilute acids and alkalis
- Resistant to heat, e.g. molten solder or heating at specific points such as by soldering tips or cigarette ends
- Frame with solid impact-resistant protective edging made of 3mm thick RAL 7047 coloured plastic
- Coating and adhesive are PVC free
- Power strip with 6 outlet sockets mounted underneath the table top, lead and earthed plug

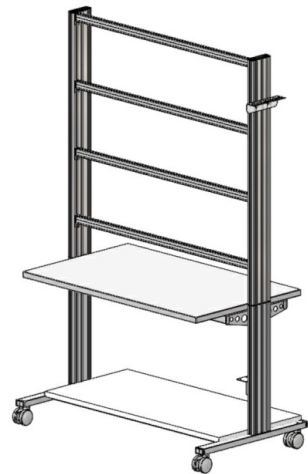

Frame:

- 2 extruded aluminium profiles with multiple grooves 1800 x 120 x 40 mm (WxHxD)
- 8 equally sized grooves in extruded aluminium profiles (3 on each side and 1 each on the front and back)
- Grooves accommodate standard industrial mountings
- 4 H-shaped aluminium profiles, 1150 mm, for 3-layer organisation of DIN A4 panels
- Space for extension of power supply duct
- Base made of rectangular tubing with 4 swiveling double casters, 2 of which have brakes
- Table frame made of tough combination of rectangular tubing around the full perimeter
- Acid-resistant epoxy-resin coating, 80 µm thick (approx.), colour RAL 7047

Cable holder:

- Width 200 mm with 12 cable slots to accommodate 48 x 4-mm safety measurement leads

PC attachment bracket:

- With 3 screw-on rubber stoppers, dimensions 65x65x114 mm approx. (top fixing for PC)

> The height of the cable holder and PC attachment bracket can be adjusted along the aluminium profiles

> For attachment to left or right, fastening materials included

> Acid-resistant epoxy-resin powder coating of thickness 80 µm approx., colour RAL 7047

Dimensions:

- Height of table top 760 mm
- 1250 x 1970 x 700 mm (WxHxD)

The mobile experiment stand is supplied in kit form and needs to be assembled by customers themselves.

67 Monitor holder for flat screen monitor of weight up to 15 kg / 33 lbs VESA 75/100

ST8010-4T

1

Pivoting monitor holder for attachment to aluminium profiles of furniture in the SybaPro range. Allows a monitor to be placed in the optimum position so that work and experiments are less tiring.



- Pivoting arm with two-part joint
- Quick-lock for adjustment to any height on extruded aluminium profile
- VESA fastening 7.5 x 7.5cm
- Includes VESA 75 (7.5x7.5) - VESA 100 (10x10) adapter
- 2 Cable clips
- Adequate carrying capacity 15 kg / 33 lbs
- TFT monitor can be turned parallel to the table edge
- Separation can be adjusted to anywhere between 105 and 480 mm

Additionally included:

Cable management set for installing cables along the profiles of the aluminium lab system furniture in the SybaPro range, consisting of:

- 3 Cross cable binders for front and rear grooves of aluminium profile
- 3 Cross cable binders for side grooves of aluminium profile
- 12 Cable ties
- 4 Aluminium cover profiles for covering and enabling wires to be run along the grooves of an aluminium profile

68 Keyboard adapter for flat screen monitor holders

ST8010-4G

1

Keyboard adapter for use in combination with flat screen monitor holders

- Mounted between monitor and mount for flat screen monitor holder
- Variable 3-level height adjustment via multiple pre-drilled mounting holes
- Two rows of mounting holes for use with equipment meeting VESA 75 and VESA 100 standards
- Keyboard shelf inclined by about 30° for comfortable and ergonomic usability
- Keyboard shelf with 11-mm folded edging to prevent falling, including handle
- Variable 2-level depth attachment for keyboard shelf (252/276 mm)
- Extra-wide keyboard shelf (640 mm) can accommodate a mouse as well
- Depth of keyboard shelf 172 mm
- Includes two cable clips for guiding and bundling cables
- Maximum load 10 kg
- Dimensions (HxWxD) 360 x 640 x 276 mm



69 Protection cover for three-level experiment trolleys

ST8010-9Y

1

Dust cover for three-level experiment trolleys

- For protecting equipment from dust and damp
- For keeping equipment out of sight (the cover must not be transparent, so is therefore opaque)
- Colour: matt dark grey with printed LN logo in orange)
- Material: nylon fabric with polyurethane coating
- High resistant to tearing, impregnated to be washable and waterproof



Recommended learning management software for all LN multimedia courses:

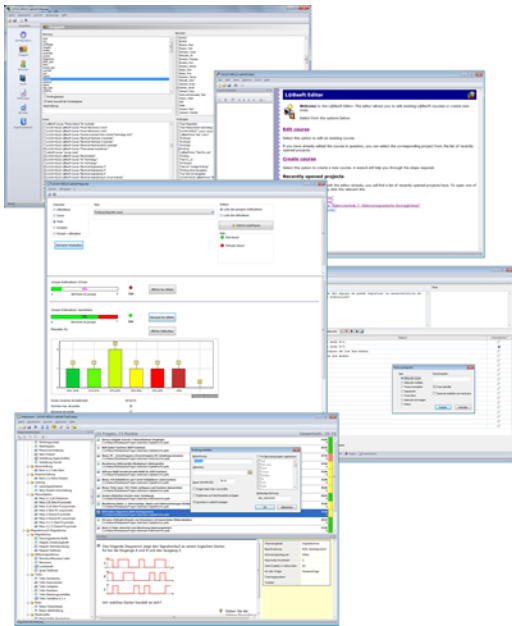

Pos.	Product name	Bestell-Nr.	Anz.
70	LabSoft Classroom Manager 5.0 software suite, single license	SO2001-5A	1

LabSoft Classroom Manager is a comprehensive set of administration software for the UniTrain system and all LabSoft courses. Classroom Manager comprises the following independent program components:

- LabSoft Manager: Administration of students and courses in LabSoft
- LabSoft Reporter: Student reports and statistics
- LabSoft Editor: Creation and editing of courses and tests
- LabSoft Questioner: Creation of questions, measuring exercises and sets of questions for courses and tests
- LabSoft TestCreator: Automatic generation of tests on the basis of sets of questions

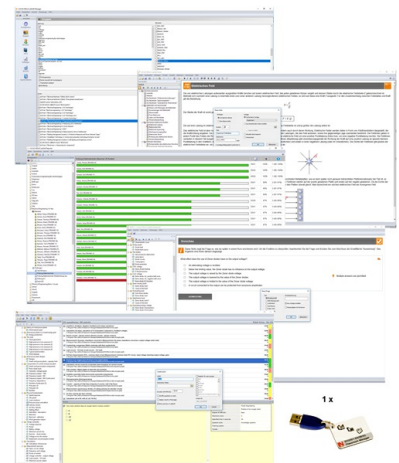

Features:

- Ease of use of all programs thanks to graphical user interface in all component programs
- For use in local area networks or on stand-alone PC
- Ease of installation
- No additional database software required
- Access control via USB dongle
- Available languages: DE, EN, ES, FR, RU, PT, ZH, LO

LabSoft Manager:

- Administration of LabSoft network installation
- Administration of an unlimited number of students and courses in LabSoft

- Addition, deletion and editing of courses and tests in LabSoft
- Addition, deletion and editing of students and student data
- Addition, deletion and editing of student groups (classes)
- Assignment of students to classes
- Activation of team function in LabSoft
- Assignment of courses and tests to students or classes

LabSoft Reporter:

- Electronic monitoring of student progress
- Graphical presentation of progress in courses and tests
- Presentation of student or group results
- Reports on courses, tests, single users or classes
- Summary of results and time
- Export of data to clipboard or file
- Display and printing of tests which have been taken with the candidate's original answers
- Multiple search options for students, classes, courses or tests

LabSoft Editor:

- HTML editor for easy to use editing of LabSoft courses
- Editing of course pages
- Wizard for creation of new courses and course pages
- Automatic inclusion of new courses in an existing LabSoft installation
- Automatic creation of IMS-compatible navigation tree without the need for programming knowledge
- Moving course pages within the navigation tree at the click of a mouse
- Editing in WYSIWYG mode
- HTML view and page preview
- Insertion of graphics, animations and tables
- Insertion of test questions
- Page templates for a variety of page types

LabSoft Questioner:

- Program for creating and editing questions, practical measuring exercises and sets of questions (question files) for electronic evaluation
- Easy creation of exercises and questions for courses and tests
- 7 different types of question: single and multiple choice, missing text, assignment, matrices, arbitrary text, selection of images
- Ability to input meta data (points, time for questions, difficulty, required resources, etc.)
- Easy specification of tolerances for practical measuring exercises
- Changes to the assessment criteria for courses or tests (including after the test has been taken)

LabSoft TestCreator:

- Program for automatically creating electronic tests from sets of questions (question files)
- Automatic and manual selection of questions and measuring exercises
- Filter functions (e.g.: type of question, difficulty) for pre-selection of questions
- Automatic generation of tests according to a set time or number of questions
- Various test options: arbitrary order of questions in a test, immediate display of results after completion
- Automatic registration of tests in LabSoft
- Preview function showing the test as created

Includes:

- CD-ROM with LabSoft Classroom Manager
- 1 USB-dongle for operation of program

System requirements:

- Server or PC with Windows 7, 8, 8.1 or 10
- Microsoft Internet Explorer 9.0 or higher
- Minimum 200 MB free disk space
- 1 free USB-port for USB-dongle

