

CE 540

Adsorptive air drying



Learning objectives/experiments

- fundamental principle of adsorption and desorption
- investigation of the variables influencing adsorption and desorption
 - ▶ air flow rates
 - ▶ air humidity and temperature
 - ▶ bed height of adsorbent
- depiction of the processes in a h-w diagram
- plotting of breakthrough curves and determination of breakthrough time



Description

- adsorptive drying of humid air
- continuous process with regeneration of adsorbent
- transparent columns and adsorbent with indicator to observe the mass transfer zone
- GUNT software with control functions and data acquisition

The CE 540 has been specifically designed to enable the complex theoretical principles of adsorption processes to be explained clearly and comprehensibly by means of experimentation.

A compressor draws in ambient air. The air flows through the water bath of a humidifier and thereafter has a relative humidity of 100%.

Before the air flows from below into the adsorption column, its relative humidity and temperature are set using a heater. The humid air flows through the adsorbent [silica gel], which is placed as a fixed bed inside a transparent column. The quantity of humidity contained in the air is adsorbed in the process. The adsorbent contains an indicator. The colour of this indicator shows the position of the mass transfer zone (MTZ). The air dried in this way exits the column and flows out into the open.

To regenerate the adsorbent, ambient air is drawn in by a second compressor. The air is heated and flows from above into the column. This desorption process can also be observed through the transparent column. The trainer enables simultaneous investigation of the adsorption and desorption processes.

Once the capacity of the adsorbent in one column is exhausted, the humid air is fed through a second column with regenerated adsorbent to dry it.

A circuit system featuring a pump and a refrigeration system is provided to adjust the temperature of the water bath in the humidifier. The temperature and humidity of the air being dried are adjusted by software. The flow rates of the two air flows can be adjusted by valves.

By recording the relative humidities and temperatures at all relevant points, the two processes can be fully balanced. The measured values are recorded by software. The software permits the adsorption and desorption processes to be depicted in a h-w diagram and enables breakthrough curves to be plotted.

CE 540

Adsorptive air drying

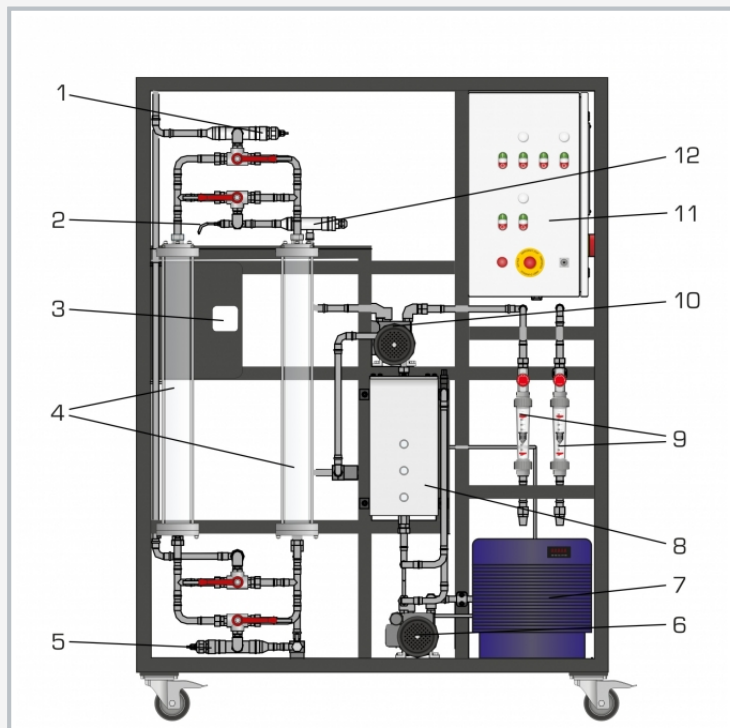

1 dried air humidity and temperature sensor, 2 regenerative air temperature sensor, 3 ambient air humidity and temperature sensor, 4 adsorption columns, 5 humidified feed air humidity and temperature sensor, 6 feed air compressor, 7 refrigeration system, 8 humidifier (water bath), 9 regenerative air and feed air flow rate sensors, 10 regenerative air compressor, 11 switch cabinet with controls, 12 regenerative air heater

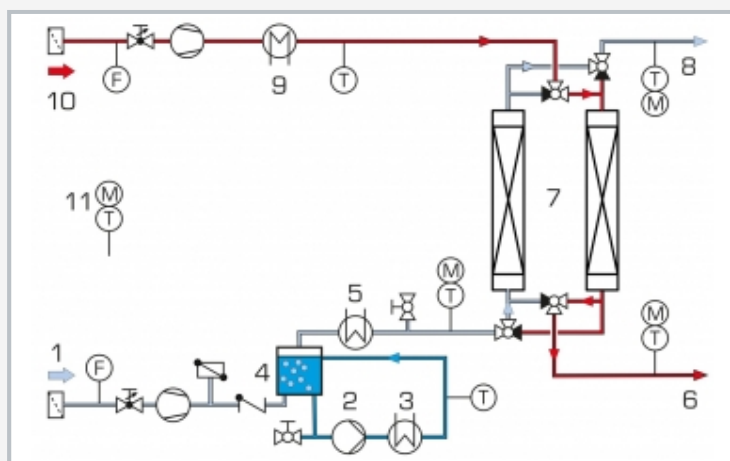

1 feed air (blue), 2 humidifier pump, 3 refrigeration system, 4 humidifier (water bath), 5 heater, 6 charged regenerative air (red), 7 adsorption columns, 8 dried air, 9 heater, 10 air for regeneration, 11 ambient air; M humidity, T temperature, F flow rate

Specification

- [1] continuous adsorptive air drying
- [2] 2 columns for alternating charging and regeneration of the adsorbent
- [3] observation of mass transfer zone by using transparent columns and adsorbent with indicator
- [4] 2 compressors to deliver the feed air and regenerative air out of the ambient atmosphere
- [5] humidification of the feed air by flowing through a water bath
- [6] circular system with pump and refrigeration system to adjust the water bath temperature
- [7] adjustment of relative humidity and temperature of feed air by heater
- [8] heater for temperature adjustment of the regenerative air
- [9] adjustment of regenerative air and feed air flow rates by valves
- [10] GUNT software with control functions and data acquisition via USB under Windows 7, 8.1, 10

Technical data

- 2 columns
 - diameter: approx. 80mm
 - height: approx. 800mm
- 2 compressors
 - max. positive pressure: 1 bar
 - max. flow rate: 8m³/h
- Humidifier pump
 - max. flow rate: 600L/h
 - max. head: 1,5m
- Refrigeration system
 - refrigerating capacity: 395W at temperature difference 10K / 250L
- 2 electric air heaters
 - power output (feed air): 160W
 - power output (regeneration): 2x 250W
- Measuring ranges
 - flow rate: 2x 0...10Nm³/h
 - air temperature: 3x 0...50°C; 1x 0...200°C, 1x -25...125°C
 - air humidity: 4x 0...100% rel.
 - water temperature: 1x 0...50°C

230V, 50Hz, 1 phase
 230V, 60Hz, 1 phase
 230V, 60Hz, 3 phases
 UL/CSA optional
 LxWxH: 1390x750x1890mm
 Weight: approx. 150kg

Required for operation

PC with Windows

Scope of delivery

trainer, 1 packing unit of silica gel E, 1 hose, 1 set tools, 1 GUNT software CD + USB cable, 1 set of instructional material