

# CE 579

## Depth filtration



The illustration shows: trainer (left) and supply unit (right)

### Description

- **filtration and backwash**
- **pressure conditions in a filter**
- **software for control and data acquisition**

Depth filtration is a key unit operation in water treatment. CE 579 enables this process to be demonstrated.

Raw water contaminated with solids is pumped from above into a filter. The solids are captured and retained as the raw water flows through the filter bed. The water itself passes through the filter bed and emerges at the bottom end of the filter. The treated water (filtrate) flows into a tank. Over time, more and more solids are deposited in the filter bed which increases its flow resistance. This process is detectable by the increasing pressure loss between the filter inlet and outlet. The flow through the filter decreases. Backwashing with treated water cleans the filter bed and reduces the pressure loss again.

The filter is equipped with a differential pressure gauge. There are also several pressure measuring points along the filter bed. The pressures are transmitted to tube manometers via hoses and displayed there as water columns. This can be used to plot Micheau diagrams. The flow rate, temperature, differential pressure and system pressure are measured. The flow velocity in the filter bed can be adjusted. Samples can be taken at all relevant points. The height of the filter bed can be read on a scale.

A software program is provided to control the operating states and measure data. A process schematic shows the current operating states of the individual components and the measured data. E.g. diatomite can be used to produce the raw water.

### Learning objectives/experiments

- pressure conditions in a filter
- factors influencing the pressure loss (Darcy's law)
  - ▶ flow rate
  - ▶ height of the filter bed
  - ▶ permeability of the filter bed
- determine the pressure in the filter bed (Micheau diagram)
- backwash of filters
  - ▶ observe the fluidisation process
  - ▶ determine the expansion of the filter bed
  - ▶ determine the required flow velocity (fluidisation velocity)

# CE 579

## Depth filtration

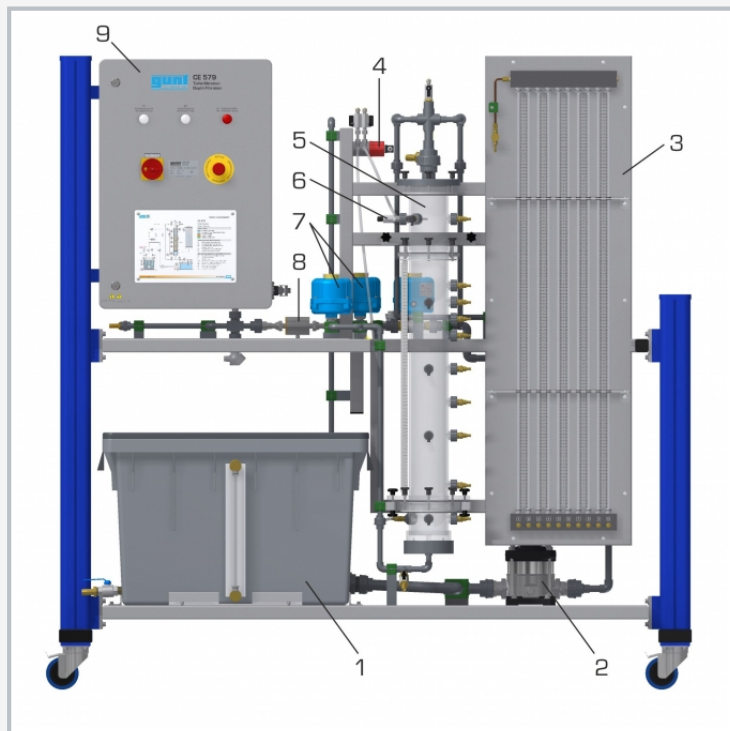

1 treated water tank, 2 backwash pump, 3 manometer panel, 4 differential pressure sensor, 5 filter, 6 system pressure sensor, 7 ball valves with motor, 8 flow rate sensor, 9 switch cabinet

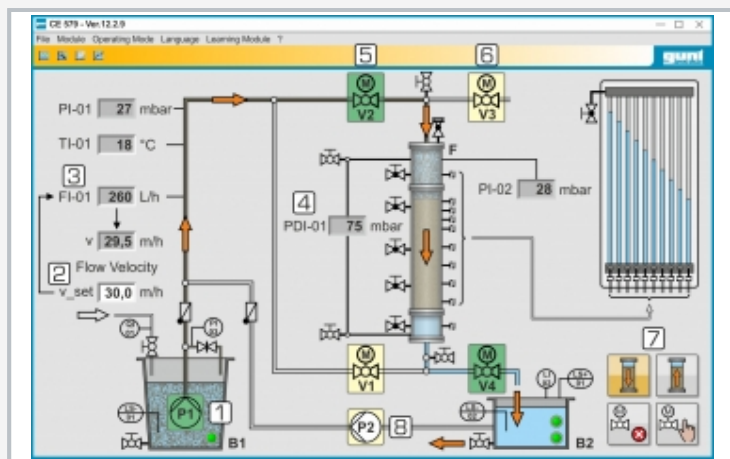

Software of CE 579 (operating state: filtration)

1 raw water pump (in operation), 2 setting the flow velocity, 3 flow rate, 4 differential pressure, 5 ball valve with motor (open), 6 ball valve with motor (closed), 7 adjustment of the ball valves with motor, 8 backwash pump (not in operation)

### Specification

- [1] depth filtration and backwash
- [2] separate supply unit with tank and pump for raw water
- [3] pump for backwashing the filter
- [4] 10 tube manometers to measure the pressures
- [5] plotting of Micheau diagrams
- [6] electromagnetic flow rate sensor
- [7] 4 ball valves with motor
- [8] measurement of flow rate, differential pressure, system pressure and temperature
- [9] flow velocity adjustable
- [10] GUNT software with control functions and data acquisition via USB under Windows 7, 8.1, 10

### Technical data

#### Filter

- inside diameter: 106mm
- total height: 1125mm
- max. filter bed height: approx. 700mm

#### Raw water pump

- max. flow rate: 150L/min
- max. head: 9m

#### Backwash pump

- max. flow rate: 40L/min
- max. head: 10m

#### Tanks for raw water and treated water

- capacity: each 180L

#### Measuring ranges

- flow rate: 0...1300L/h
- tube manometers: 10x 0...1260mmWC
- differential pressure: -1...1bar
- system pressure: 0...2,5bar
- temperature: 0...100°C
- filter bed height: 0...720mm

- 230V, 50Hz, 1 phase
- 230V, 60Hz, 1 phase
- 230V, 60Hz, 3 phases

UL/CSA optional

LxWxH: 1900x790x1900mm (trainer)

LxWxH: 1200x790x1200mm (supply unit)

Total weight: approx. 370kg

### Required for operation

water connection, drain, PC with Windows

### Scope of delivery

trainer, 1 supply unit, 1 set of hoses, 1 packing unit of gravel, 1 packing unit of diatomite, 1 sieve with collecting pan, 5 measuring cups, 1 GUNT software CD + USB cable, 1 set of instructional material