

CE 582

Water Treatment Plant 2



The illustration shows from left to right: manometer panel, trainer, supply unit.

Description

- example of a water treatment plant
- depth filtration and ion exchange
- backwash of sand filters and regeneration of ion exchangers

Depth filtration with sand filters and ion exchange are key unit operations in water treatment. CE 582 enables these two operations to be demonstrated.

The raw water is pumped from above into a sand filter. Solids are captured and retained as the raw water flows through the filter bed. The filtered water emerges from the bottom end of the sand filter and then flows through two ion exchangers (cation and anion exchangers). In the process, unwanted ions are exchanged for hydrogen and hydroxide ions. The raw water is softened and desalinated. The sand filter and the two ion exchangers can be used in combination or separately. The solids deposited in the sand filter result in an increase in pressure loss. Backwashing cleans the filter bed and reduces the pressure loss. The ion exchangers can be regenerated with acid or caustic.

The sand filter is equipped with a differential pressure measurement. There are also several pressure measuring points along the filter bed. The pressures are transmitted to tube manometers via hoses and displayed there as water columns. This can be used to plot Micheau diagrams. The flow rate, temperature, conductivity, differential pressure and system pressure are measured. The flow velocity in the filter bed (filter velocity) can be adjusted. Samples can be taken at all relevant points. E.g. diatomite can be used to produce the raw water.

A software program is provided to control the operating states and measure data. A process schematic shows the current operating states of the individual components and the measured data.

Learning objectives/experiments

- familiarization with the fundamental principle of the unit operations depth filtration and ion exchange
- observation and determination of pressure losses in a sand filter
- plotting of Micheau diagrams
- principle of backwash
- identification of the different modes of operation of cation and anion exchangers
- regeneration of ion exchangers

CE 582

Water Treatment Plant 2

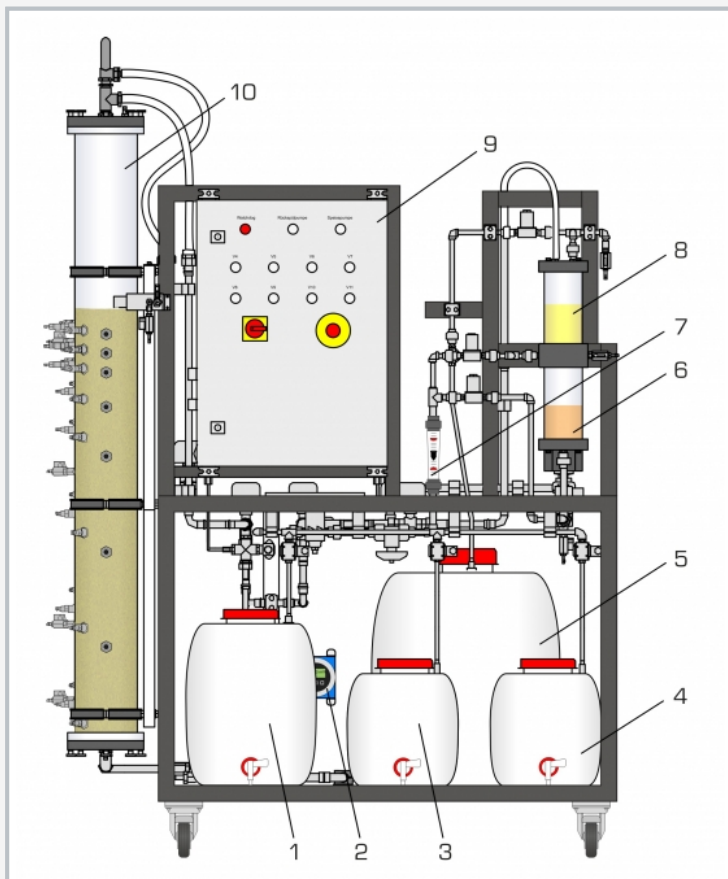

1 rinsing water tank, 2 electromagnetic flow rate sensor, 3 acid tank, 4 caustic tank, 5 collecting tank, 6 cation exchanger, 7 flow meter, 8 anion exchanger, 9 switch cabinet, 10 sand filter

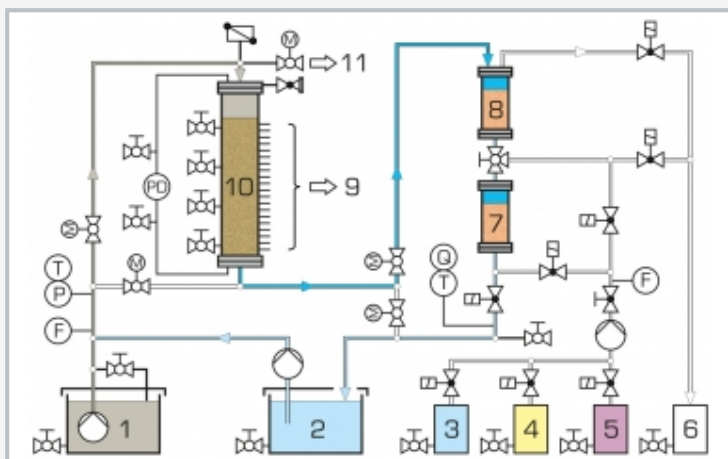

1 raw water, 2 treated water, 3 distilled water, 4 caustic soda, 5 hydrochloric acid, 6 collecting tank, 7 anion exchanger, 8 cation exchanger, 9 manometer panel, 10 sand filter, 11 water from backwashing; E conductivity, F flow rate, P system pressure, PD differential pressure, T temperature

Specification

- [1] water treatment with depth filtration and ion exchange
- [2] sand filter, cation and anion exchanger
- [3] all processes usable separately or in combination
- [4] backwash of sand filter
- [5] regeneration of ion exchangers
- [6] differential pressure measurement of sand filter
- [7] 20 tube manometers to measure the pressures in the filter bed
- [8] plotting of Michau diagrams
- [9] measurement of flow rate, temperature, conductivity, differential pressure and system pressure
- [10] filter velocity adjustable
- [11] GUNT software with control functions and data acquisition via USB under Windows Vista or Windows 7

Technical data

Raw water pump

- max. flow rate: 25m³/h
- max. head: 20m

Backwash pump

- max. flow rate: 3m³/h
- max. head: 37m

Tanks for raw water and treated water

- capacity: each approx. 180L

Measuring ranges

- flow rate (raw water): 0...1300L/h
- flow rate (regeneration): 2...25L/h
- differential pressure: -1...1bar
- system pressure: 0...4bar
- tube manometers: 20x 0...1500mm
- conductivity: 0...600µS/cm
- temperature: 0...100°C
- filter velocity: approx. 0...70m/h

230V, 50Hz, 1 phase

LxWxH: 1550x920x2200mm (trainer)

LxWxH: 1400x800x1150mm (supply unit)

LxWxH: 750x640x1840mm (manometer panel)

Total weight: approx. 440kg

Required for operation

Caustic soda, hydrochloric acid, distilled water
PC with Windows

Scope of delivery

trainer, 1 supply unit, 1 manometer panel, 1 packing unit of gravel, 1 packing unit of diatomite, 1 packing unit of cation exchanger, 1 packing unit of anion exchanger, 1 set of hoses, 1 GUNT software CD + USB cable, 1 set of instructional material