

CE 620

Liquid-liquid extraction



Learning objectives/experiments

- transition of a component from a two-component liquid mixture into a solvent by extraction
- scale-up from beaker experiment to pilot plant scale
- enrichment of transition component in extract by distillation
- evaluation of separation processes via concentration measurement and mass balances
- influence of different experimental options on separation processes

Description

- separation of a liquid mixture by liquid-liquid extraction in counterflow operation
- enrichment of extract using integrated distillation column
- operation in either continuous or discontinuous process mode is possible
- design and materials allow investigation of different ternary systems
- adjustment and observation of phase boundary possible

The CE 620 allows liquid mixtures to be separated using liquid-liquid extraction.

The liquid mixture to be separated is delivered from the feed tank into the bottom of the extraction column using a pump. There, it moves in counterflow towards the solvent, which is delivered into the top of the extraction column by a pump.

The mixture to be separated is made up of a transition component and carrier liquid. The carrier liquid and the solvent are insoluble in one another and therefore a phase boundary is established in the column. This can be observed and can be adjusted using two valves. The movement of the transition component from the carrier liquid into the solvent occurs inside the column. Two three-way valves can be used to operate the trainer as a continuous or a discontinuous process.

A distillation unit facilitates the enrichment of the transition component in the extract. This consists of a heated round-bottomed flask with a packed column and a distillation bridge with Liebig condenser. The enriched extract leaves the column at the top and is collected in a tank. The bottom temperature is measured by a sensor, displayed digitally and controlled using a PID controller.

The temperature at the top of the distillation column is also measured. Distillation removes the solvent from the transition component which is collected at the bottom of the unit and can be drawn off as a product. The separated solvent is collected in a tank and can be reused for extraction.

For a ternary material system, rapeseed oil is recommended as the carrier liquid with ethanol as the transition component and water as the solvent. For this ternary material system the concentrations of extract, top and bottom product are determined by measurement of density. A conductivity meter is included for alternative ternary material systems.

CE 620

Liquid-liquid extraction

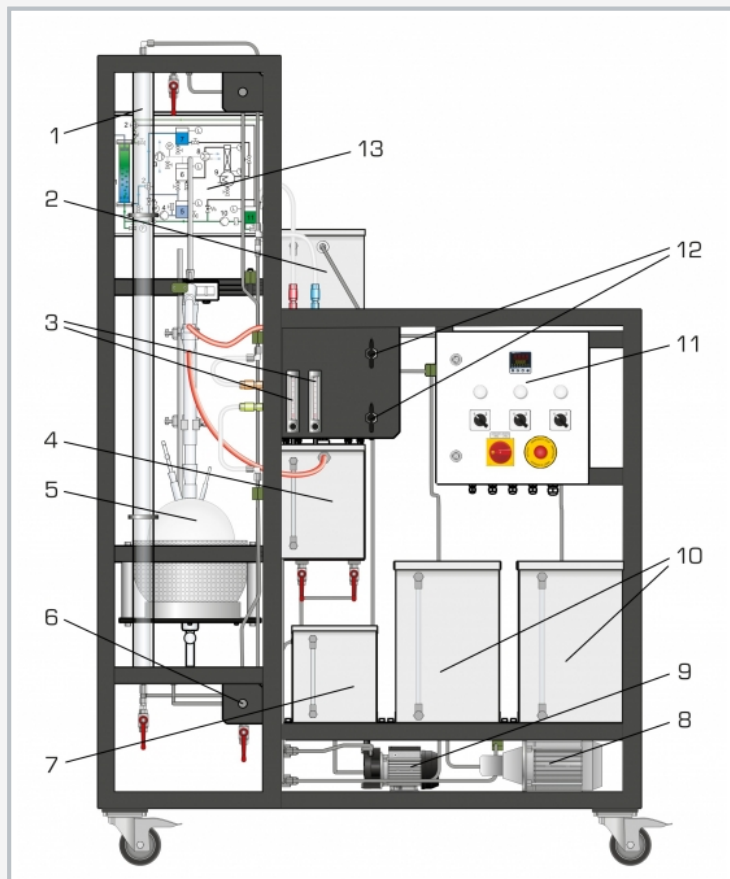

1 extraction column, 2 extract tank, 3 flow meters feed and solvent, 4 top product tank (distillation), 5 distillation unit, 6 valve for phase boundary, 7 solvent tank, 8 feed pump, 9 solvent pump, 10 feed and raffinate tank, 11 switch cabinet, 12 three-way valves, 13 process schematic

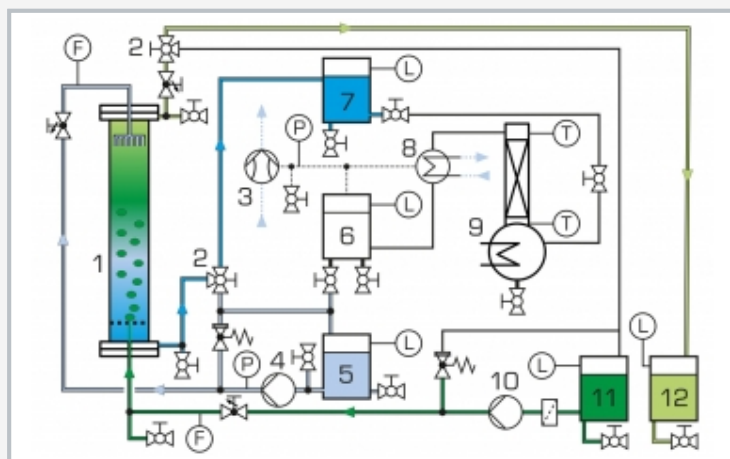

1 extraction column, 2 three-way valves, 3 water jet pump, 4 solvent pump, 5 solvent tank, 6 top product tank (distillation), 7 extract tank, 8 Liebig condenser with cooling water connection, 9 distillation column, 10 feed pump, 11 feed tank, 12 raffinate tank; F flow rate, P pressure, T temperature, L level

Specification

- [1] liquid-liquid extraction in counterflow operation with distillation for enrichment of the extract
- [2] operation as continuous or discontinuous process using 2 three-way valves
- [3] glass extraction column
- [4] distillation column and distillation bridge with Liebig condenser
- [5] electrical bottom heating via PID controller
- [6] water jet pump for reduction of evaporation temperature during distillation
- [7] stainless steel tanks for feed, solvent, raffinate, extract and top product (distillation)
- [8] 2 pumps to deliver the feed and solvent
- [9] 2 valves for adjusting the phase boundary
- [10] distillation column packed with Raschig rings

Technical data

Columns

- extraction: diameter: 40mm, height: 1500mm
- distillation: diameter: 30mm, height: 415mm

Bottom heater power output: 1200W

Tanks

- feed and raffinate: approx. 30L each
- solvent and extract: approx. 15L each
- top product (distillation): 15L
- bottom tank (distillation): approx. 5L

Feed pump

- max. flow rate: 1000mL/min
- max. head: 80m

Solvent pump

- max. flow rate: 1200mL/min
- max. head: 10m

Water jet pump: final vacuum: approx. 200mbar

Measuring ranges

- temperature: 1x 0...150°C, 1x 0...120°C
- flow rate: 2x 100...850mL/min (water)
- pressure: -1...0,6bar
- conductivity: 0...1990µS/cm

230V, 50Hz, 1 phase

230V, 60Hz, 1 phase

120V, 60Hz, 1 phase

UL/CSA optional

LxWxH: 1350x750x2150mm

Weight: approx. 180kg

Required for operation

water connection: 720L/h

Scope of delivery

- 1 trainer
- 1 set of accessories
- 1 conductivity meter
- 1 set of hoses
- 1 set of instructional material