

CE 715

Rising film evaporation



Learning objectives/experiments

- fundamental principle of film evaporation for increasing the concentration of temperature-sensitive solutions
- investigation of the variables influencing the solid concentration in the solution
- influence of pressure and feed flow rate on the separating process
- influence of flow rate and pressure of the heating steam on the separating process
- investigation of the variables influencing the energy efficiency of the process
- energy balances at heat exchangers
- system cleaning while installed

Description

- rising film evaporator for increasing the concentration of temperature-sensitive solutions
- hygienic operation due to carefully selected materials such as stainless steel and glass
- cleaning possible while installed
- counterflow process

Evaporators are used in process engineering and food technology for increasing the concentration of solutions. Part of the solvent is removed by evaporation, which means that the solution retains a higher concentration of dissolved solids. Film evaporators are used in particular for temperature-sensitive solutions such as milk.

The CE 715 allows the operating behaviour of a rising film evaporator to be investigated. The untreated solution is fed from the feed tank below into the evaporator. The evaporator is a double pipe heat exchanger that is heated by steam. The steam pressure on the casing side is adjusted with a PID controller. A cyclone is installed after the evaporator to separate the evaporated solvent and the concentrated solution. The solvent vapour removed is condensed in a water-cooled condenser and collected in a tank. The concentrated solution can also be collected in a tank or fed back into the evaporator for the concentration to be increased further.

The two tanks, the cyclone and the condenser are made of glass for better observation. The system can also be operated under a vacuum to reduce the boiling point of the solvent. All relevant pressures, temperatures and flow rates are measured to allow evaluation and monitoring of the process.

To clean the system while installed, a pump and cleaning nozzles are fitted in the condensate and concentrate tanks.

Common salt and water are the recommended materials for experiments.

CE 715

Rising film evaporation

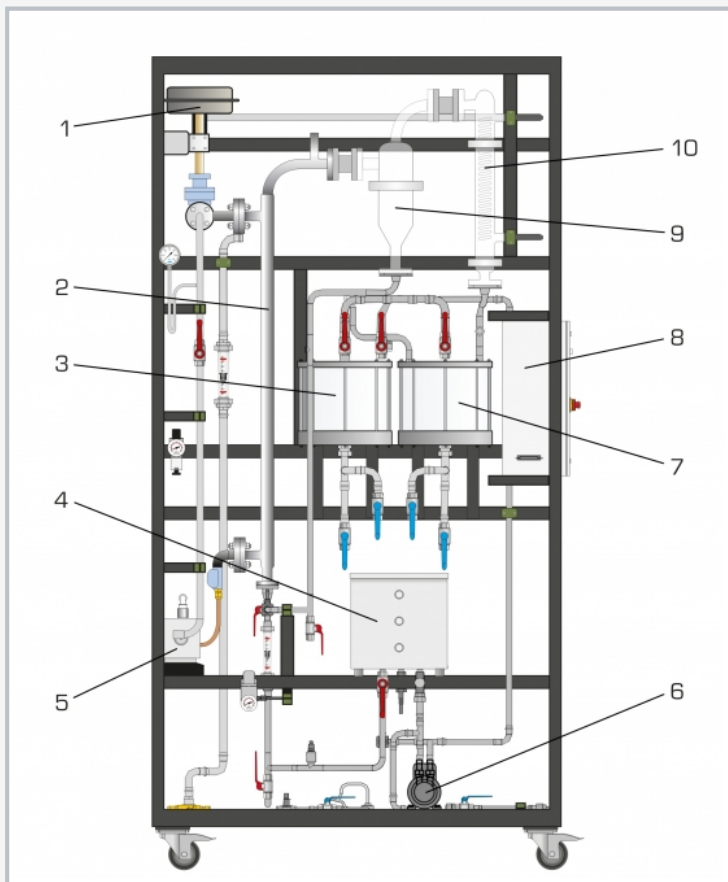

1 heating steam control valve, 2 rising film evaporator, 3 concentrate tank, 4 feed tank, 5 water jet pump, 6 cleaning pump, 7 condensate tank, 8 switch cabinet, 9 cyclone, 10 condenser

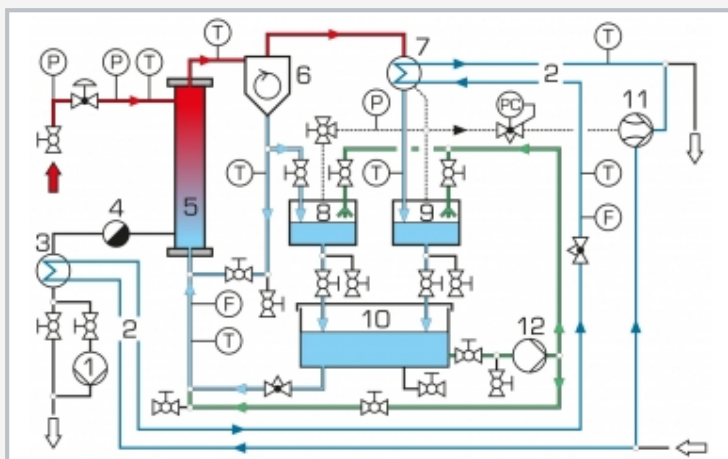

1 heating steam condensate pump, 2 cooling water, 3 condensate cooler, 4 steam trap, 5 rising film evaporator, 6 cyclone, 7 condenser, 8 concentrate tank, 9 condensate tank, 10 feed tank, 11 water jet pump, 12 cleaning pump; F flow rate, P pressure, L level, T temperature

Specification

- [1] rising film evaporator for increasing the concentration of temperature-sensitive solutions
- [2] stainless steel steam-heated single pipe evaporator
- [3] control valve for adjustment of steam pressure via PID controller
- [4] water jet pump and vacuum controller to reduce the evaporation temperature
- [5] separation of concentrated solution and evaporated solvent using glass cyclone
- [6] glass condenser for condensation of removed solvent vapour
- [7] stainless steel feed tank
- [8] glass tanks for concentrate and condensate
- [9] measurement of flow rate, pressure and temperature
- [10] steam supply from laboratory network or CE 715.01

Technical data

Rising film evaporator

- heat transfer surface: approx. 0,08m²
- length: approx. 1,2m

Control valve: Kvs value: 0,4m³/h

Water jet pump

- final vacuum: approx. 100mbar
- flow rate: approx. 90L/min

Vacuum controller: -100...0kPa

Condenser for solvent vapour

- heat transfer surface: approx. 0,2m²

Tanks

- feed: approx. 30L
- concentrate, condensate: approx. 10L each

Measuring ranges

- temperature: 7x 0...170°C
- pressure: -1...1bar; 0...6bar (abs); 0...10bar
- flow rate: 2...36L/h; 0...1000L/h

230V, 50Hz, 1 phase

230V, 60Hz, 1 phase

120V, 60Hz, 1 phase

LxWxH: ca. 1360x750x2640mm

Weight: approx. 300kg

Required for operation

Cooling water: 200...300L/h

Compressed air (control valve): 3...4bar, max. 300L/h

Heating steam: max. 2bar, 4...6kg/h

Scope of delivery

- 1 trainer
- 1 set of hoses
- 1 set of instructional material

CE 715

Rising film evaporation

Optional accessories

083.71501 CE 715.01 Electrical steam generator 12kW