



Table of Contents

Table of Contents	1
Automotive Hybrid & EV	2
Fundamentals of Automotive Technology Trainer	2
UniTrain - Electronic and Electrical Trainer	3
DC and AC Technology in the Motor Vehicle	4

Fundamentals of Automotive Technology Trainer



Fundamentals of Automotive Technology Trainer

Teaching fundamentals is always the vital cornerstone for solid and efficient education. Several training courses have been specifically developed for this topic area to teach trainees step by step the basic knowledge to be covered in detail at a later date. The courses are particularly suited for school education and require little or no previous knowledge.

Each multimedia course starts by imparting the theoretical foundations before solidifying that knowledge by means of practical measurements. The particular focus is on handling measuring instruments and the way that simple electric circuits operate.

UniTrain - Electronic and Electrical Trainer



UniTrain - Electronic and Electrical Trainer

Please choose your product:

DC and AC Technology in the Motor Vehicle



DC and AC Technology in the Motor Vehicle

The growing importance of electrical and electronic components in the motor vehicle makes the hands-on training approach to basic electronic circuits an absolute necessity. Our UniTrain-I course on DC and AC technology in the vehicle enable students to acquire this know-how through independent selflearning. They come to grips with such terms as current, voltage and resistance, train in how to operate measuring instruments and conduct experiments using Ohm's and Kirchhoff's laws. All of the required measuring instruments are already built into the UniTrain-I's multimedia training environment.

List of articles:

Pos.	Product name	Bestell-Nr.	Anz.
1	Course - Automotive 1: "DC and AC circuits in vehicles"	CO4204-7A	1

This training system provides trainees with the perfect introduction to the topics of direct and alternating current. All the relevant contents are taught with the help of easily understood animations and interactive experiments. Thanks to the numerous test pages in the course, teachers can obtain feedback on students' progress at any time, as can the individual students themselves.

Includes:

- 1 Experiment card with various resistor circuits
- 1 Experiment card with voltage divider circuits
- 1 Experiment card with circuits for investigating temperature-dependent, light-dependent and voltage-dependent resistors
- Storage case
- Disc with Labsoft browser and course software

Training contents:

- Fundamentals of electricity
- Circuits
- Measurement of voltage and current
- Calculation of current, voltage and resistance
- Series circuits
- Parallel circuits
- Mixed series and parallel circuits
- Ohm's law
- Kirchhoff's 1st law
- Kirchhoff's 2nd law
- Simple voltage dividers
- Temperature-dependent NTC (negative temperature coefficient) thermistors
- Temperature-dependent PTC (positive temperature coefficient) thermistors
- Light-dependent resistors (LDRs)
- Voltage-dependent resistors (VDRs)
- Troubleshooting (9 simulated faults activated by relays)
- Course duration: 10 h approx. (including about 1.5 h for troubleshooting)

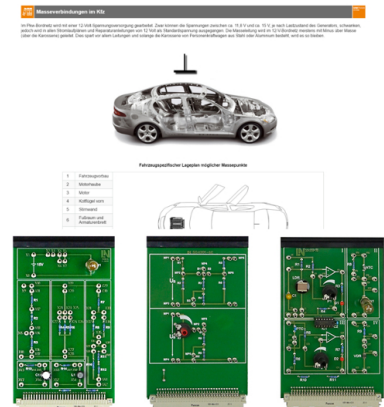

Additionally required:

The UniTrain-I system is a computer-based training and experimentation system for vocational and further training and education in the areas of basic and advanced electrical engineering and electronics. Its multimedia courses combine cognitive and hands-on (haptic) training units into a comprehensive unified concept, specifically enabling students to acquire skills in the handling of equipment. Starting with basic courses and advancing to cover a huge variety of electrical engineering and electronics topics, a wide range of multimedia courses is available for study in school or in professional and advanced training courses. The UniTrain-I system is completely self-contained and can be used anywhere at any time. The multimedia learning environment the system provides high degrees of motivation, and maximum learning effectiveness in laboratories, at work or at home. It thus becomes a guarantor for effective and efficient study. Access to the multimedia courses and control of virtual instruments and experiment hardware is provided by LabSoft, the system's open experiment platform. The courses teach the theoretical building blocks and provide experiments to be carried out using the course-specific experiment hardware. The intelligent measurement interface supplies the analog and digital measuring and control I/O and represents, in combination with the system's virtual instruments, a high quality item of laboratory equipment. In addition, students' progress can be monitored and electronically documented on the basis of fault finding experiments with faults simulated by the hardware as well as tests of knowledge. The electrical and electronic circuits needed for the experiments are connected to the system with the aid of an Experimenter module.

Pos.	Product name	Bestell-Nr.	Anz.
2	UniTrain Interface with virtual instruments (basic VI)	CO4203-2A	1

The UniTrain Interface is the central unit of the UniTrain system. It incorporates all inputs and outputs, switches, power and signal sources and measurement circuitry needed to perform experiments. The Interface is controlled via the connected PC.

Equipment:

- 32-bit processor with storage memory for measurements
- USB interfaces, transfer rate 12 Mbits/s
- WLAN/WiFi interface, 2.4 GHz, IEEE 802.11 b/g/n
- Simultaneous connection of any number of Experimenters via serial bus system
- High-quality designer casing with aluminium feet and surface-hardened Plexiglas front panel
- Suitable for accommodating in training panel frames for DIN A4 training panels
- Designed for connection of 2-mm safety measuring leads
- Multi-coloured LEDs for displaying status
- Adjustable analog output, +/- 10 V, 0.2 A, DC – 5 MHz, via BNC and 2-mm sockets
- 4 Analog differential amplifier inputs with 10 MHz band width, safe for voltages up to 100 V, sampling rate 100 mega samples, 9 measuring ranges, memory depth 4 x 8 k x 10 bits, inputs via BNC (2 inputs) or 2-mm sockets (4 inputs)
- 2 Analog inputs for current measurement, overcurrent-protected up to 5 A, sampling rate 250 kilo samples, 2 measuring ranges, resolution 12 bits, connection via 2-mm sockets
- 3 variable analog outputs +/- 20V, 1 A, DC-150 Hz (requires CO4203-2B)
- 16-bit digital signal output, of which 8 bits are accessed via 2-mm sockets, TTL/CMOS, clock frequency 0 – 100 kHz, electric strength +/- 15 V

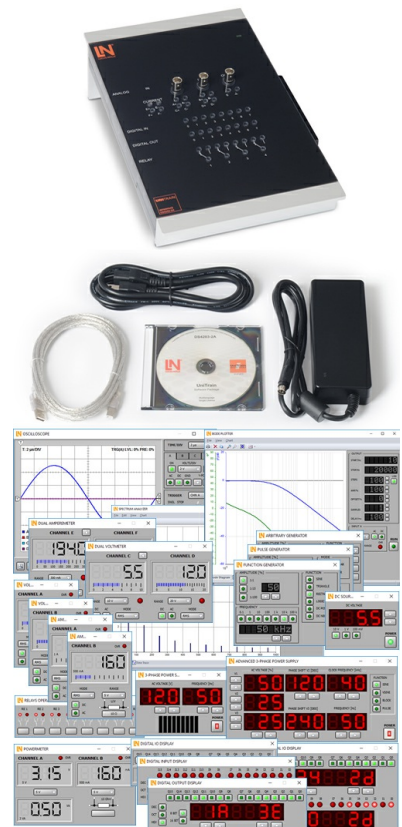

- 16-bit digital signal input, of which 8 bits are accessed via 2-mm sockets, memory depth 16 bit x 2 k, TTL/CMOS, sampling rate 0 – 100 kHz, electric strength +/- 15 V,
- 8 Relays, 24 V DC/1 A, of which 4 are accessed via 2-mm sockets
- Dimensions: 29.6 x 19 x 8.6 cm
- External power supply with wide range input 100-264 V, 47-63 Hz, output 24 V/5 A
- Weight (including power supply): 2.1 kg

Virtual instruments (meters and sources):

- 2 x Voltmeter VIs, 2 x Ammeter VIs: AC, DC, 9 ranges, 100 mV to 50 V, true RMS, AV
- 1 x Power meter, 9 ranges, 100 mV to 50 V
- 1 x VI with 8 relays, 1 x Multimeter VI: multimeter display (optional LM2330, LM2331 or LM2322) in LabSoft
- 1 x 2-channel ammeter VI: AC, DC, 2 ranges, 300 mA and 3 A, TrueRMS, AV
- 1 x 2-channel voltmeter VI: AC, DC, 9 ranges, 100 mV to 50 V, TrueRMS, AV
- 1 2-/4-channel oscilloscope: band width 10 MHz, 25 time ranges, 100 ns/div to 10 s/div, 9 ranges 20 mV/div to 10 V/div, trigger and pre-trigger, XY and XT modes, cursor function, addition and multiplication function for 2 channels
- 1 x VI Spectrum Analyzer: 9 voltage ranges 100 mV to 50 V, input frequency range 3 Hz to 1 MHz, time domain display
- 1 X VI Bode-Plotter: 9 voltage ranges 100 mV to 50 V, frequency range 1 Hz - 5MHz, time domain display and locus diagram
- 1 x Adjustable DC voltage VI 0 - 10 V
- 1 x Function generator VI: 0.5 Hz - 5 MHz, 0 - 10 V, sine, square, triangular,
- 1 x Arbitrary generator VI, 1 x Pulse generator VI
- 1 x VI with 16 digital outputs, 1 x VI with 16 x digital inputs, 1 x VI with 16 digital input/outputs. Display modes: binary, hex, decimal and octal numerals
- 1 x Three-phase power supply VI, 0 - 150 Hz, 0 - 14 Vrms, 2 A (requires CO4203-2B)
- 1 x Adjustable DC power supply VI, 3 x (-20 V - +20 V), 2 A (requires CO4203-2B)
- 1 x Three-phase power supply VI with additional phase-shift and clock rate adjustment (requires CO4203-2B)

Includes:

- Interface
- Power supply
- Power lead
- USB cable
- CD with basic software
- Operating manual

System requirements:

- Personal computer with Windows Vista, Windows 7, Windows 8, Windows 8.1, Windows 10 (32 or 64 bit)
- CD-ROM drive for installing software
- USB port for connection to Interface

3 UniTrain Experimenter

CO4203-2B

1

UniTrain Experimenter for coupling to the UniTrain Interface or to other Experimenter modules.

Equipment:

- Connects to the UniTrain Interface and additional Experimenters via UniTrain bus
- UniTrain bus connection for experiment cards
- High-quality designer casing with aluminium feet and surface-hardened Plexiglas front window
- Suitable for accommodating training panel frames for DIN A4 training panels
- Fixed and variable voltages available via 8 2-mm sockets
- Designed for connection of 2-mm safety measuring leads
- Accommodates UniTrain experiment cards
- Eject mechanism for UniTrain experiment cards with return spring
- Accommodates a breadboard for experimenting with discrete components and integrated circuits
- Accommodates a multimeter using IrDa interface
- Dimensions: 29.6 x 19 x 8.6 cm
- Weight: 1.0 kg

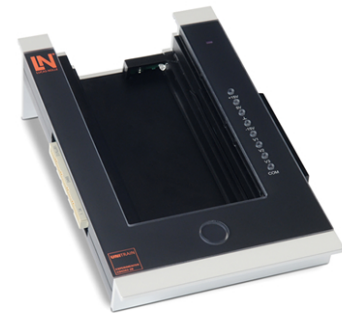

4 UniTrain measurement accessories, shunts and connection cables

CO4203-2J

1

Shunt resistors on a PCB, for current measurement using the analog inputs of the UniTrain system.

- 6 Shunt resistors: 2 x 1 ohm, 2 x 10 ohm, 2 x 100 ohm
- Screen print of symbols for identifying resistors, the voltage taps and current inputs
- 24 x 2-mm sockets
- Dimensions: 100 x 40 mm

Set of connection cables 2mm (28 pcs) for UniTrain consisting of:

- 8 x connection leads 2mm, 15cm, blue
- 4 x connection leads 2mm, 15cm, yellow
- 5 x connection leads 2mm, 45cm, black
- 2 x connection leads 2mm, 45cm, yellow
- 5 x connection leads 2mm, 45cm, red
- 2 x connection leads 2mm, 45cm, blue
- 1 x safety adapter lead 4mm to 2mm, 50cm, black
- 1 x safety adapter lead 4mm to 2mm, 50cm, red
- 10 x 2-mm connector plugs / Plug spacing 5mm, white

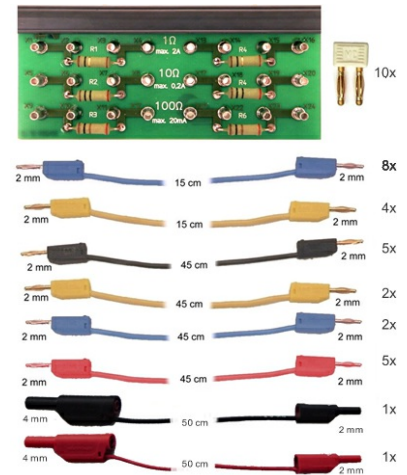

Additionally recommended

Pos.	Product name	Bestell-Nr.	Anz.
------	--------------	-------------	------

5 UniTrain storage case for one system

CO4203-2Y

1

Sturdy aluminium case with moulded foam block to accommodate a complete UniTrain system (without equipment)

- Capable of accommodating 1 Interface, 2 Experimenters, 1 power supply as well as cables and smaller accessories
- Lockable padlock; stable padlock hinge
- Colours: aluminium, black, chrome
- Dimensions: 610 x 480 x 100 mm
- Weight: 4,6 kg

