

ET 144

Electrical installation in refrigeration systems



Learning objectives/experiments

- read, understand, wire and test electric circuit diagrams
- design and operation of electrical components from refrigeration
 - ▶ start-up capacitor
 - ▶ operating capacitor
 - ▶ start-up relay
 - ▶ time relay
 - ▶ timer
 - ▶ circuit breaker
 - ▶ start-up current limiter
 - ▶ contactors
 - ▶ pressure switch
 - ▶ thermostat
 - ▶ solenoid valve
- design and testing of a safety chain
- star / delta connection
- change of direction of rotation in an alternating current circuit
- **safety aspects when handling mains voltage**

Description

- **design and wiring of typical electrical circuits from refrigeration**
- **investigation of important electrical components from refrigeration**
- **design and investigation of a safety chain**

The wiring of electrical components is a typical task in the field of refrigeration. Besides the design and operation of the individual components, knowledge about the interaction of the components in circuits is an important learning objective. Safety aspects also play an important role. With ET 144 this knowledge and these skills can be acquired.

The electrical components are arranged clearly visible. All components are connected on terminal blocks. Using the cables included in the scope of delivery it is possible to set up different circuits correctly and operationally. Lamps simulate the consumers. All components are operated and tested with mains voltage to provide high relevance for practice.

There are electrical components for the start and operation of refrigerant compressors, such as e.g. electromagnetic start-up relay and capacitor.

With a timer, circuits can be designed and examined for cyclical defrosting in refrigeration systems. This also includes the correct programming of the timer. Typical safety components, such as pressure switches, thermostats and circuit breakers are also included in the scope of delivery. These components enable the design and examination of a typical safety chain for refrigeration.

ET 144

Electrical installation in refrigeration systems

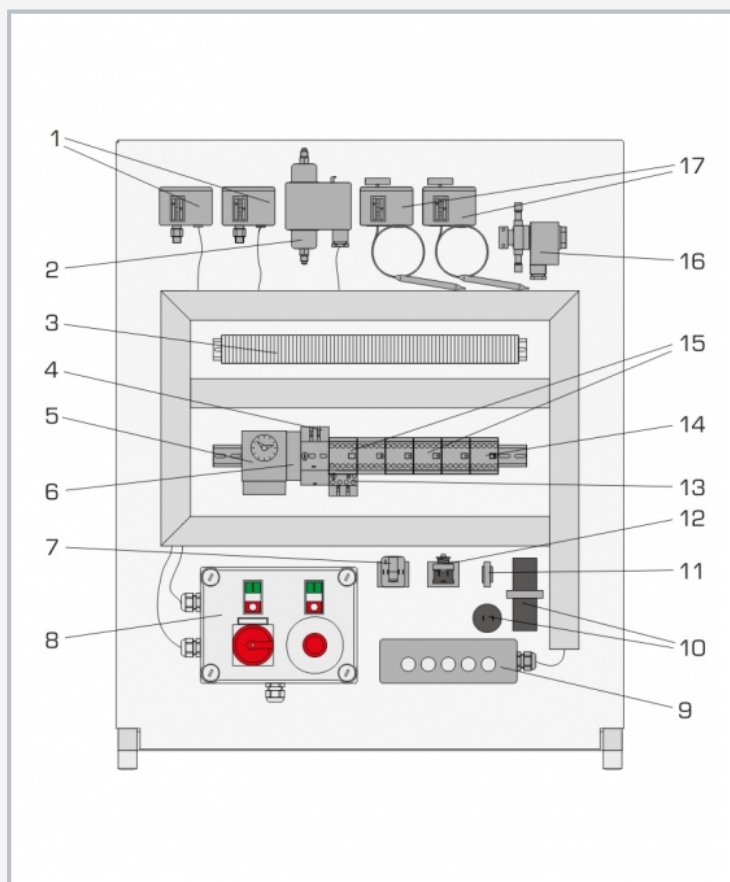

1 pressure switch, 2 differential pressure switch, 3 terminal block, 4 circuit breaker with start-up current limiter, 5 timer, 6 thermistor circuit breaker, 7 PTC start-up relay, 8 switch cabinet, 9 lamps, 10 capacitors, 11 bimetallic circuit breaker, 12 electromagnetic start-up relay, 13 adjustable protection relay, 14 time relay, 15 contactor, 16 solenoid valve, 17 thermostat

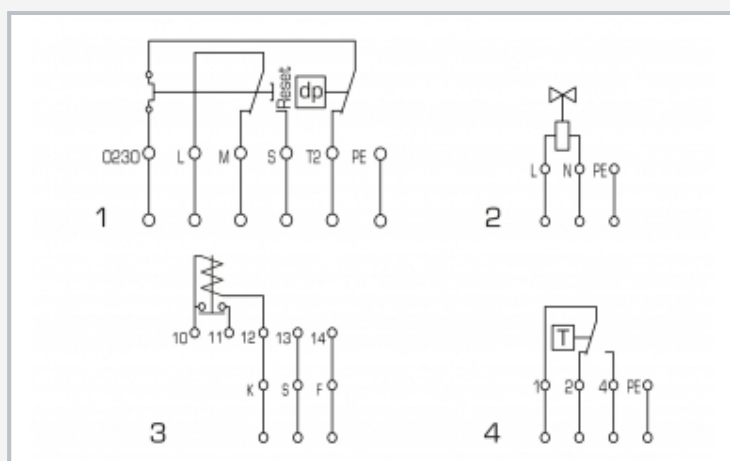

Circuit diagrams: 1 differential pressure switch, 2 solenoid valve, 3 electromagnetic start-up relay, 4 thermostat

Specification

- [1] experimental unit from the GUNT practical series for the training of mechatronics engineers for refrigeration
- [2] design and investigation of circuits with electrical components from refrigeration
- [3] electrical components mounted clearly visible and connected on terminal blocks
- [4] 1 set of cables with wire end ferrules for wiring electrical components on terminal blocks
- [5] 3 pressure switches, 2 thermostats, 1 solenoid valve, 1 timer, 4 circuit breakers, 5 contactors, 3 relays, 2 capacitors
- [6] 5 lamps to simulate consumers

Technical data

- 3 pressure switches
 - high pressure: 8...32bar
 - low pressure: -0,9...7bar
 - differential pressure: 0,3...4,5bar
- 2 thermostats: -5...20°C
- 1 timer
 - 2 switchable outputs
 - switching time: 1...60min
- 4 circuit breakers
 - bimetallic circuit breaker
 - thermistor circuit breaker
 - circuit breaker with start-up current limiter
 - adjustable protection relay
- 5 contactors
 - 2x: 3 NO, 1 NC
 - 3x: 4 NO
- 3 relays
 - electromagnetic start-up relay
 - PTC start-up relay
 - time relay

Start-up and operating capacitor: 15µF, 80µF

400V, 50Hz, 3 phases
 230V, 60Hz, 1 phase
 LxWxH: 820x420x1010mm
 Weight: approx. 42kg

Scope of delivery

- 1 experimental unit
- 1 set of accessories (cables + wire end ferrules)
- 1 set of instructional material

ET 144

Electrical installation in refrigeration systems

Optional accessories

020.30009 WP 300.09 Laboratory trolley