

ET 172

Electrical faults in refrigerant compressors



Description

- real refrigerant compressor from practice
- investigation of important electrical components from refrigeration
- simulation of 15 faults

Identifying electrical faults in refrigeration systems requires comprehensive knowledge. This knowledge includes the design and operation of the individual electrical components as well as the reading of circuit diagrams. ET 172 helps to acquire this knowledge.

The electrical components for the start and operation of a refrigerant compressor are clearly visibly arranged in a transparent showcase and already wired. The capacitor and start-up relay required for the motor are examined. Typical protection devices, such as circuit breaker and automatic fuse, are also arranged clearly visible.

The simulation of 15 different faults, e.g. coil fracture in the motor, short circuit in the operating capacitor or welded contacts in the start-up relay, is possible. For fault indication, voltages and resistances are checked at the lab jacks with the multimeter. The depiction of the circuit diagram on the front panel facilitates the allocation of the measuring points.

Learning objectives/experiments

- electrical connection of refrigerant compressors
- read and understand electrical circuit diagrams
- design and operation of the electrical components of a refrigerant compressor
 - ▶ start-up capacitor
 - ▶ start-up relay
 - ▶ operating capacitor
 - ▶ overheat protection
 - ▶ main contactor
 - ▶ automatic fuse
- fault finding in electrical components
 - ▶ in idle state
 - ▶ under mains voltage

ET 172

Electrical faults in refrigerant compressors

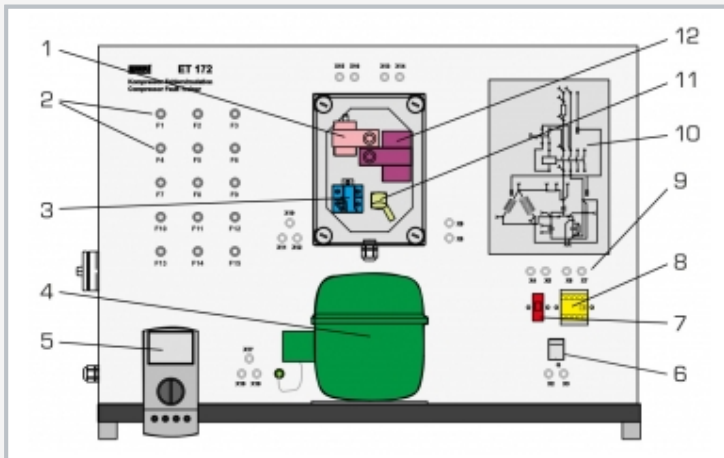

1 operating capacitor, 2 buttons for faults, 3 start-up relay, 4 refrigerant compressor, 5 multimeter, 6 main switch, 7 automatic fuse, 8 main contactor, 9 lab jacks, 10 circuit diagram, 11 overheat protection, 12 start-up capacitor

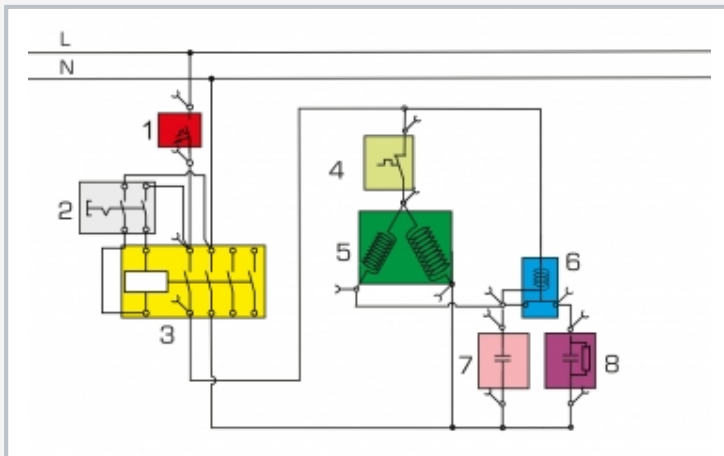

1 automatic fuse, 2 main switch, 3 main contactor, 4 overheat protection, 5 refrigerant compressor, 6 start-up relay, 7 operating capacitor, 8 start-up capacitor

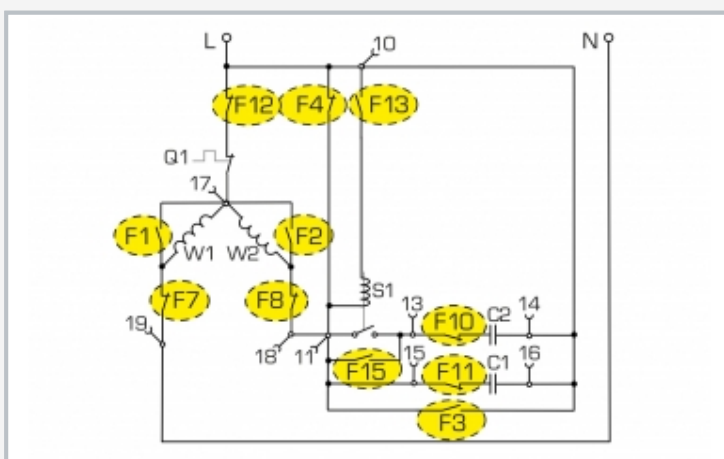

Fault simulation in the compressor: F1, F7 main winding fault, F2, F8 auxiliary winding fault, F3, F10, F11 operating and start-up capacitor fault, F12 overheat protection faulty, F13, F15 start-up relay faulty

Specification

- [1] Experimental unit from the GUNT practical series for the training of mechatronics engineers for refrigeration
- [2] Investigation of the electrical components for the operation of a refrigerant compressor
- [3] Real refrigerant compressor from practice
- [4] Electrical components for the start and operation of the compressor arranged in the transparent switch cabinet
- [5] General safety devices mounted clearly visible
- [6] Circuit diagram depicted on the front panel
- [7] Identification of 15 faults: multimeter measures voltages or resistances at the lab jacks

Technical data

Refrigerant compressor

- power consumption: approx. 870W

Electrical components for the compressor

- start-up capacitor
- start-up relay
- operating capacitor
- overheat protection (bimetallic)

General safety devices

- main contactor
- automatic fuse

230V, 50Hz, 1 phase

230V, 60Hz, 1 phase

120V, 60Hz, 1 phase

LxWxH: 900x400x650mm

Weight: approx. 60kg

Scope of delivery

- 1 experimental unit
- 1 multimeter
- 1 set of instructional material

ET 172

Electrical faults in refrigerant compressors

Optional accessories

020.30009

WP 300.09

Laboratory trolley