

ET 180

Pressure switches in refrigeration



Description

- gain expert knowledge of refrigeration through practical exercises
- checking and adjustment of pressure switches in refrigeration
- clear arrangement at the front panel
- display of switching states via lamps
- independent pressure generation via compressor

With this experimental unit the operation of the pressure switches, also called pressostats, used in refrigeration can be demonstrated.

Pressure switches are used to protect the compressor and system components against too high or too low pressures. They are also used in the so-called pump-down circuits for the controlled shut-down of the compressor. Dependent on the application, individual pressure switches or combined pressure switches are used for high and low pressures.

Pressure switches for monitoring the pressures are available. The switching states are indicated by signal lamps. The switching thresholds and hystereses can be set by the trainee. This allows him to examine and understand the switching behaviour of the pressure switch. A typical refrigerant compressor generates the test pressures. Manometers indicate the pressures. Air is used as a pressure medium. The hazard-free operation of the pressure switches uses 24V.

Learning objectives/experiments

- gain expert knowledge of refrigeration through practical exercises
- operation of a pressure switch
- difference between low and high pressure switches
- difference between NC and NO contacts of a switch
- setting the switching threshold
- setting the differential gap
- recording the switching behaviour of the pressure switch over pressure

ET 180

Pressure switches in refrigeration



1 controls, 2 compressor, 3 receiver, 4 fan, 5 vent valve, 6 high pressure pressure switch, 7 combined pressure switch, 8 low pressure pressure switch, 9 signal lamps for switching state, 10 manometer

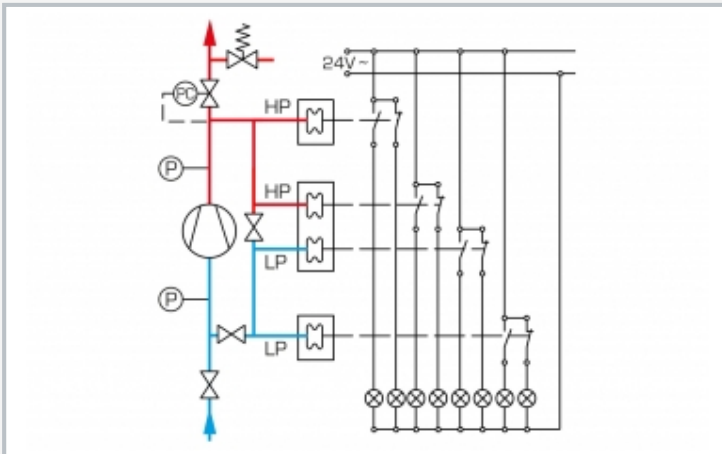

P pressure measuring point, PC pressure keeping valve, HP pressure switch, LP pressure switch; blue: low pressure, red: high pressure

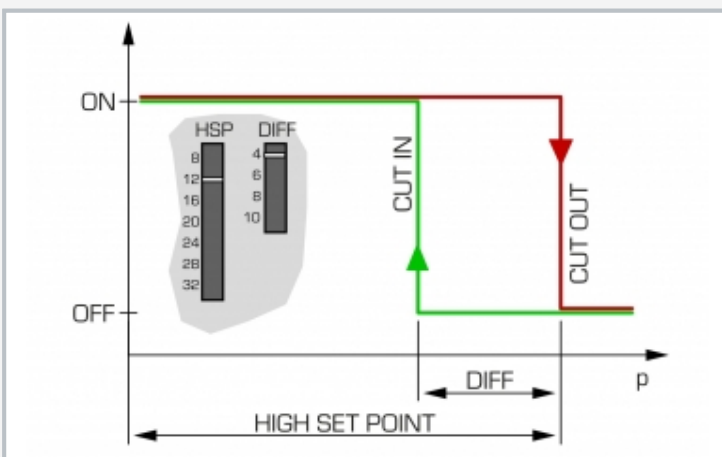

Adjustment and operation of a high pressure pressure switch: HSP switch-off pressure, DIFF switch-on difference, CUT IN switch-on, CUT OUT switch-off

Specification

- [1] experimental unit from the GUNT practical series for the training of mechatronics engineers for refrigeration
- [2] operation and adjustment of pressure switches in refrigeration
- [3] low pressure, high pressure and combined pressure switches
- [4] indication of switching states via signal lamps
- [5] pressure generation via independent refrigerant compressor, pressure medium air
- [6] pressure adjustment via pressure keeping valve
- [7] hazard-free operation of the pressure switches at 24V

Technical data

Compressor pressure range: -0,9...24bar

Pressure switches adjustment range

- low pressure: -0,9...7,0bar
- hysteresis: 0,7...4,0bar
- high pressure: 8,0...32,0bar
- hysteresis: 4...10bar

Measuring ranges

Manometer

- low pressure: -1...9bar
- high pressure: -1...24bar

230V, 50Hz, 1 phase

230V, 60Hz, 1 phase

120V, 60Hz, 1 phase

LxWxH: 1.000x650x530mm

Weight: approx. 60kg

Scope of delivery

- 1 experimental unit
- 1 set of instructional material

ET 180

Pressure switches in refrigeration

Optional accessories

020.30009 WP 300.09 Laboratory trolley