

ET 192

Replacement of refrigeration components



Description

- practical service tasks in refrigeration systems
- replace typical components of a refrigeration system: compressor, pressure switch, filter/drier, solenoid valve and expansion valve
- refrigerant displacement, replacement, evacuation, filling and siphoning off

The replacement of a faulty compressor or other components of the refrigeration system are amongst the repeated activities of a mechatronics engineer for refrigeration. ET 192 allows for training in these processes. The consequences of incorrect procedures can be demonstrated.

The components are integrated into an operational refrigeration system. This allows for the practical testing of the functionality of individual components after replacement. The following activities must be carried out e.g. after replacing a compressor:

Refrigerant displacement (pump-down) into the condenser/receiver
(should this not be possible: siphoning off the refrigerant)
Disconnection of the compressor at the service valves
Disconnection of electrical connections

Compressor replacement, correcting oil level, if necessary
Reconnecting electrical connections
Reconnecting the compressor with the service valves
Evacuating the compressor and making the connection to the system
Compressor test run, checking for leaks and replenish refrigerant, if necessary
Checking the system pressures

To carry out the service tasks, the tool set ET 150.02 and the filling and evacuation equipment ET 150.01 are required.

Learning objectives/experiments

- familiarisation with and carry out basic activities for the servicing of refrigeration systems
- replacement of
 - ▶ compressor
 - ▶ pressure switch
 - ▶ filter/drier
 - ▶ solenoid valve
 - ▶ expansion valve
- refrigerant displacement (pump-down)
- mechanical and electrical assembly and disassembly of components
- replenish refrigerant and compressor oil
- leak test
- compressor test run
- adjustment of expansion valve and pressure switch

ET 192

Replacement of refrigeration components

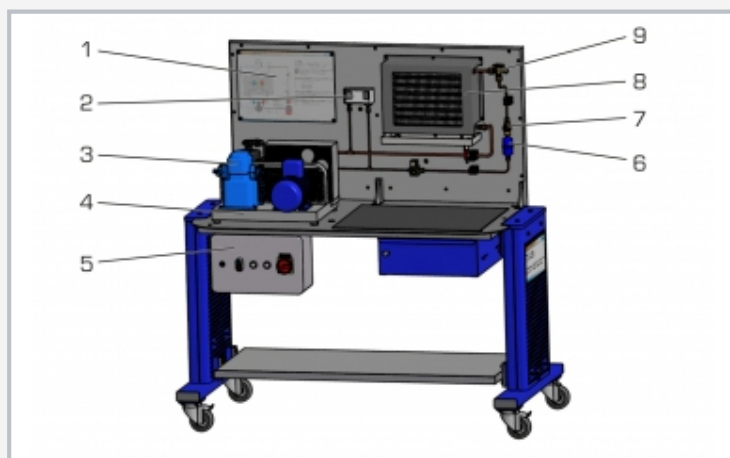

1 process schematic, 2 pressure switch, 3 condenser, 4 compressor, 5 controls, 6 filter/drier, 7 sight glass, 8 evaporator, 9 expansion valve

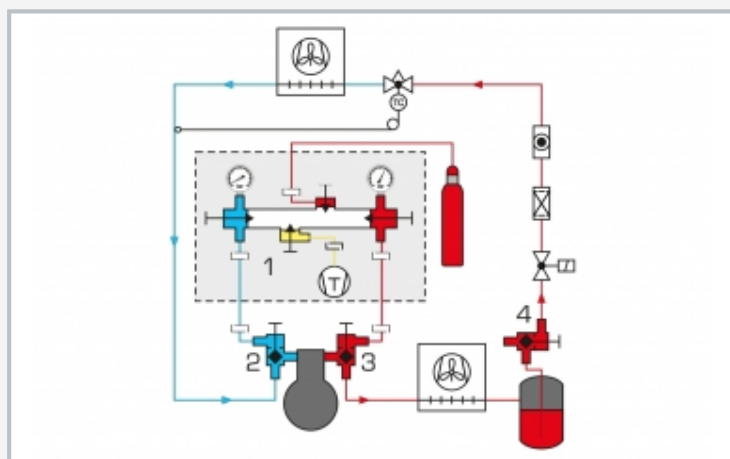

Example: valve position for normal operation, assembly aid is connected and indicates operating pressures
 1 assembly aid, 2 intake side service valve, 3 delivery side service valve, 4 receiver shut-off valve; blue: low pressure, red: high pressure

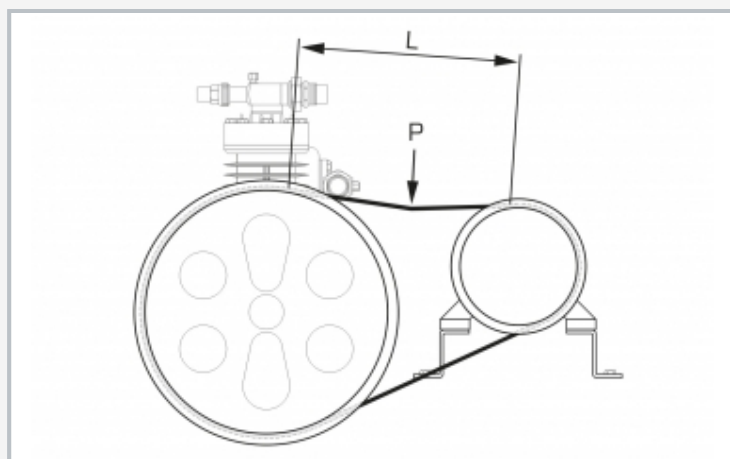

Checking and adjustment of the belt tension

Specification

- [1] trainer from the GUNT practical series for the training of mechatronics engineers for refrigeration
- [2] service exercises in refrigeration systems
- [3] complete refrigeration circuit with open compressor, air-cooled condenser, receiver and air cooling evaporator
- [4] replaceable components: compressor, filter/drier, pressure switch and solenoid valve
- [5] required accessories evacuation equipment ET 150.01 and tool set ET 150.02
- [6] overall arrangement on robust workbench
- [7] refrigerant R134a, CFC-free

Technical data

Open refrigerant compressor

- drive power: 0,75kW
- refrigeration capacity: 1245W at -5°C/36°C
- maximum system pressure: 18bar

Pressure switch

- LP: -0,2...7bar
- HP: 10...32bar

230V, 50Hz, 1 phase
 230V, 60Hz, 1 phase
 120V, 60Hz, 1 phase
 UL/CSA optional
 LxWxH: 1400x750x1650mm
 Weight: approx. 150kg

Scope of delivery

- 1 trainer
- 1 set of instructional material

ET 192

Replacement of refrigeration components

Required accessories

061.15001	ET 150.01	Refrigerant filling and evacuation equipment
061.15002	ET 150.02	Tool set