

ET 252

Solar cell measurements



Description

- **four solar cells and bypass diodes that can be freely interconnected**
- **regulated Peltier module for controlling the solar cell temperature**
- **adjustable illuminance**
- **software with tutorials and data on load profiles for recording characteristic curves**

Illuminance, temperature and electrical load are the key variables affecting photovoltaic solar cells. ET 252 allows you to conduct targeted experiments in order to understand the basic principles and practically relevant effects on cells and modules.

Four solar cells are illuminated by a lamp field with adjustable illuminance. They can be precisely maintained at a selectable set temperature thanks to a regulated Peltier module. Using the set of cables provided, the cells can be interconnected in a number of ways, via a patch panel. For example, individual cells can be bridged by bypass diodes in order to examine differences in power loss such as caused by shaded cells.

A rheostat is integrated into the patch panel to manually record current-voltage curves. Current and voltage measurements are detected via the built-in measuring unit. Automated measurements can be taken by software by specifying electrical load patterns.

Illuminance, current, voltage and temperature are all detected by corresponding sensors and can be displayed and logged in the software program.

The software also includes a comprehensive tutorial feature. This feature allows individual learning objectives to be reviewed by an automatically generated selection of various test questions and exercises.

Learning objectives/experiments

- physical behaviour of solar cells under varying illuminance and temperature
- recording of current-voltage curves
- calculating current strength and achievable output based on the single diode model
- how illuminance and temperature affect the curves
- Interconnecting solar cells in parallel and series connection
- effect of bypass diodes
- power degradation due to shading

ET 252

Solar cell measurements



1 lighting unit, 2 four monocrystalline Si solar cells, 3 control unit, 4 Peltier module, 5 patch panel

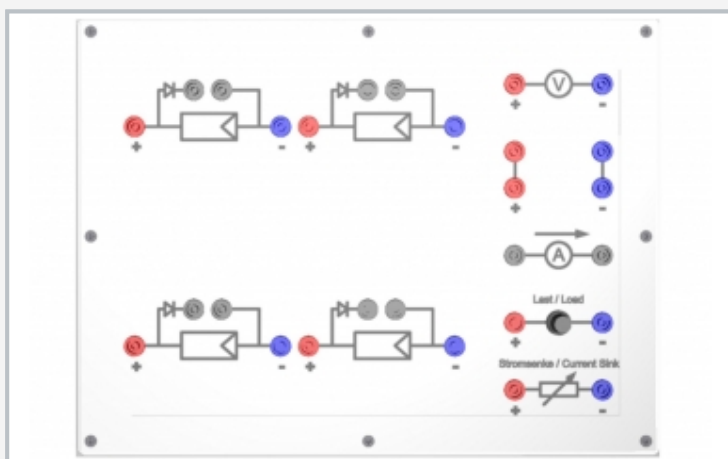

Patch panel for different connection possibilities

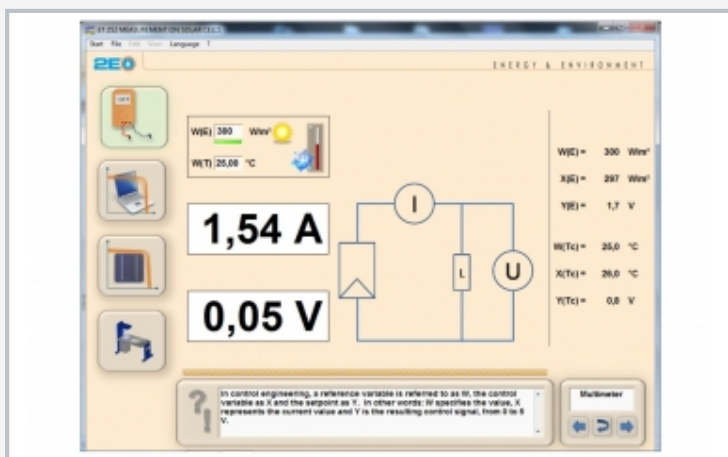

Comprehensive software with tutorial feature

Specification

- [1] trainer for solar cell measurements
- [2] four monocrystalline silicon solar cells
- [3] lighting unit with adjustable illuminance
- [4] backing for solar cells with Peltier module for regulating temperature
- [5] patch panel with bypass diodes and adjustable load resistance for selectable types of connection with individual cells
- [6] function for automated measuring of characteristic curves
- [7] reference cell as illuminance sensor
- [8] GUNT software for data acquisition via USB under Windows 7, 8.1, 10
- [9] GUNT software with operating status display and tutorial feature

Technical data

- Cell type: monocrystalline
 Cell size: 125x125mm
 Typical characteristics of a cell:
- fill factor: 76%
 - max. output: 2,45W
 - current at max. output: approx. 4,8A
 - voltage at max. output: approx. 0,5V
 - short-circuit current: approx. 5,4A
 - open-circuit voltage: approx. 0,6V

Peltier module: 20°C...60°C
 Lighting unit: 4x 100W

230V, 50Hz, 1 phase
 230V, 60Hz, 1 phase
 LxWxH: 1610x800x1480mm
 Weight: approx. 130kg

Required for operation

PC with Windows

Scope of delivery

- 1 trainer
- 1 set of cables
- 1 GUNT software CD + USB cable
- 1 set of instructional material