

ET 292

Fuel cell system



Description

- **water-cooled polymer-membrane fuel cell combined heat and power**
- **integrated control and monitoring of all operating and safety parameters**
- **GUNT software for control and data acquisition**

Fuel cells are energy converters that, unlike heat engines, convert chemical energy directly into electrical energy. Heat is generated as a by-product during this process.

The main component of ET 292 is a polymer-membrane fuel cell which is operated in combined heat and power generation. The system is supplied with high-purity hydrogen from a pressure vessel on the anode side and with oxygen from the ambient air on the cathode side. The fuel cell is operated either current-regulated or voltage-regulated via an integrated electronic load. The setpoint of the electronic load allows a precise adjustment of all operating points and a very accurate recording of characteristics.

The technically usable thermal energy is dissipated to the environment via a cooling circuit and can be accounted for via the integrated instrumentation. The water accruing during operation is collected in a water separator. In the fuel cell's dead-end mode the accruing water is disposed of via a configurable purge valve for hydrogen. The system is operated via a PC.

Auxiliary energy for pump, fan and control required for operation is provided from the mains. The moisture in the stack can be regulated via adjustment of the purge valve, so that no external humidification is required. All relevant measuring values are recorded to work out the fuel cell's energy balance. The measured values are transmitted directly to a PC via USB. The GUNT data acquisition software is included.

Learning objectives/experiments

- conversion of chemical energy into electrical and thermal energy
- function and design of a fuel cell system
- relationships of fuel cell operating parameters
- effects on the electrical performance of fuel cells
- recording and visualisation of all relevant voltage/current characteristics
- calculation of relevant variables

ET 292

Fuel cell system



1 fuel cell, 2 cathode blower, 3 low-pressure reducing valve, 4 inlet valve, 5 cooling water pump 6 main switch, 7 water separator, 8 water cooler, 9 visual flow indicator, 10 cooling water tank

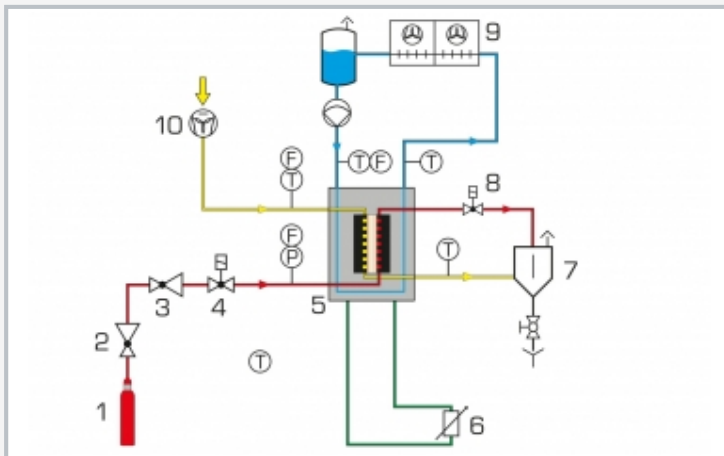

1 hydrogen pressure vessel, 2 high-pressure reducing valve, 3 low-pressure reducing valve, 4 inlet valve, 5 fuel cell, 6 electronic load, 7 water separator, 8 purge valve, 9 water cooler, 10 cathode blower; red: hydrogen, yellow: ambient air, blue: cooling water, green: load circuit; F flow rate, P pressure, T temperature

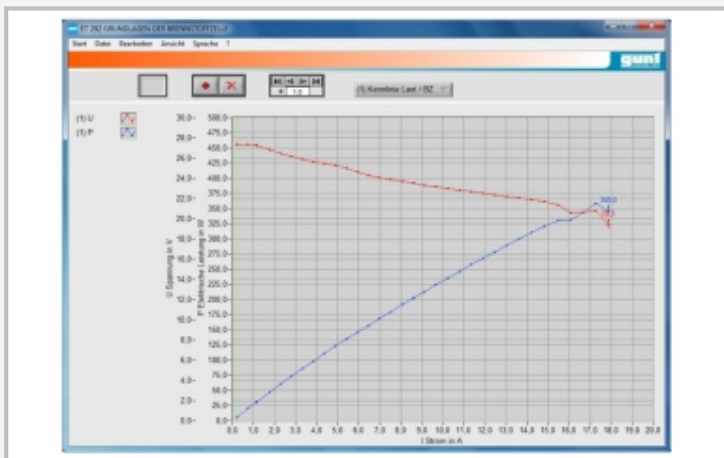

Software screenshot: characteristic of the fuel cell

Specification

- [1] investigation of a polymer-membrane fuel cell
- [2] water cooled system in combined heat and power
- [3] hydrogen supplied via standard pressure vessel
- [4] high-pressure reducing valve for hydrogen pressure vessel supplied
- [5] oxygen supplies directly from the ambient air
- [6] precise adjustment of all operating points via electronic load
- [7] operation without external humidification
- [8] sensors for flow rate, pressure, temperature, voltage and current strength
- [9] complete operation and evaluation via a PC
- [10] GUNT software with control functions and data acquisition via USB under Windows 7, 8.1, 10

Technical data

Nominal output: 300W
 Thermal power: approx. 400...500W depending on ambient conditions
 Required ambient temperature: 5...35°C
 Required inlet pressure: 2...200bar

Measuring ranges

- flow rate:
 - ▶ 0...0,5L/min (cooling water)
 - ▶ 0...20sL/min (hydrogen)
 - ▶ 0...100sL/min (air)
- pressure: 0...500mbar (hydrogen)
- temperature:
 - ▶ 0...50°C (ambient)
 - ▶ 0...70°C (stack)
- humidity: 0...100% (ambient)
- voltage: 0...40V (stack)
- current: 0,1...20A (stack)

230V, 50Hz, 1 phase
 230V, 60Hz, 1 phase
 120V, 60Hz, 1 phase
 UL/CSA optional
 LxWxH: 1750x780x1770mm
 Weight: approx. 180kg

Required for operation

Hydrogen of purity 3.0 in pressure vessel
 PC with Windows

Scope of delivery

- 1 trainer
- 1 hydrogen hose
- 1 high-pressure reducing valve for hydrogen pressure vessel
- 1 GUNT software CD + USB cable
- 1 set of instructional material