

# ET 350

## Changes of state in the refrigeration circuit



### Description

- refrigeration circuit demonstrated clearly
- transparent components offer insights into the changes of state
- energetic analyses of the refrigeration cycle

In a compression refrigeration system a refrigerant flows through the refrigeration circuit and is subject to different changes of state. Here, the physical effect is used that during the transition of the refrigerant from a liquid to a gaseous state energy is required which is removed from the environment (evaporation enthalpy).

The experimental unit ET 350 represents a typical refrigeration circuit consisting of a hermetic piston compressor, condenser, expansion valve and evaporator. The evaporator and condenser are transparent to provide good monitoring of the phase transition process during evaporation and condensation. The operation of the float valve as expansion valve is also easy to observe. Before the entry into the evaporator the aggregate state of the refrigerant can be monitored at a sight glass. A water circuit cools the condenser or supplies the cooling load for the evaporator. Cold and hot water and refrigerant flows are adjustable. The low pressure level of the refrigerant

SES36 used permits the use of an evaporator and condenser out of glass. The refrigerant is CFC-free and environmentally friendly.

Temperatures and pressures are recorded and displayed. The key points of the cyclic process can be read and entered into a log p-h diagram. The power of the compressor and flow rates of the water flows and the refrigerant are also indicated.

### Learning objectives/experiments

- design and operation of a compression refrigeration system
- observe the evaporation and condensation of the refrigerant
- represent and understand the refrigeration cycle in the log p-h diagram
- energy balances
- calculation of the coefficient of performance

# ET 350

## Changes of state in the refrigeration circuit



1 pressure switch, 2 flow meter, 3 condenser, 4 expansion valve, 5 compressor, 6 evaporator, 7 sight glass, 8 temperature display, 9 manometer

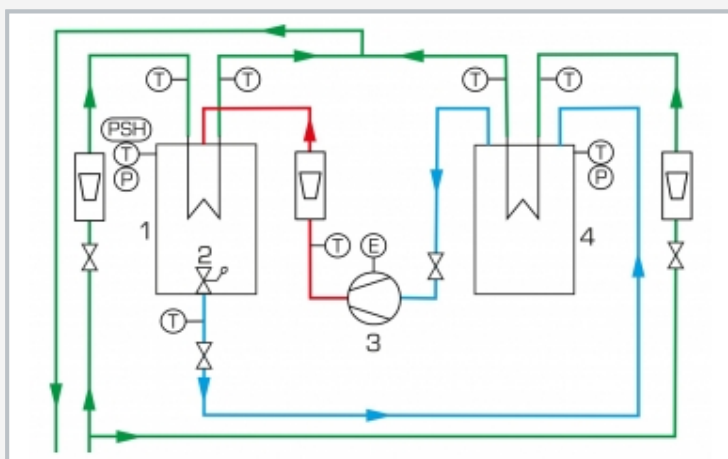

1 condenser, 2 expansion valve, 3 compressor, 4 evaporator; T temperature, P pressure, E electrical power, PSH pressure switch; blue: low pressure, red: high pressure, green: water

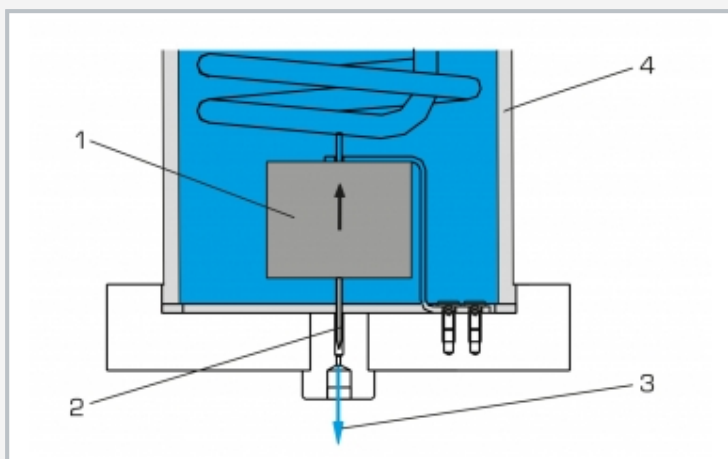

Expansion valve in the shape of a float valve: 1 float lifts the needle from the valve seat, 2 needle, 3 refrigerant escapes, 4 tank

### Specification

- [1] demonstration of the processes in a refrigeration circuit
- [2] for better process monitoring the evaporator and condenser are of transparent design
- [3] evaporator and condenser with pipe coil
- [4] expansion valve in the shape of a float valve
- [5] pressure switch to protect the compressor
- [6] temperature sensor, power meter, manometer in the refrigeration circuit, flow meter for hot and cold water and refrigerant
- [7] safety valves at the evaporator and condenser
- [8] refrigerant Solkatherm SES36, CFC-free

### Technical data

Hermetic piston compressor

- capacity: 18,3cm<sup>3</sup>

Evaporator capacity: approx. 2800mL

Condenser capacity: approx. 2800mL

Measuring ranges

- temperature: 8x -20...200°C
- pressure: 2x -1...1,5bar
- flow rate (water): 2x 0...48L/h
- flow rate (refrigerant): 1x 0...700L/h
- power: 0...1200W

230V, 60Hz, 1 phase

120V, 60Hz, 1 phase

UL/CSA optional

LxWxH: 1200x500x900mm

Weight: approx. 110kg

### Required for operation

water connection, drain

### Scope of delivery

- 1 experimental unit
- 3,5 kg refrigerant Solkatherm SES36
- 1 set of supply hoses
- 1 set of instructional material

## ET 350

### Changes of state in the refrigeration circuit

Optional accessories

020.30009

WP 300.09

Laboratory trolley