

ET 420

Ice stores



The illustration shows the trainer on the left, the dry cooling tower in the middle and the wet cooling tower on the right.

Description

- industrial refrigeration system with ice store, dry cooling tower and wet cooling tower
- energy efficiency in refrigeration and air conditioning technology

Ice stores are used in refrigeration to cover an increased additional cooling requirement (peak load). The ice stores are usually charged over night when general energy requirements and energy costs are low.

To charge and discharge the ice store a circuit with glycol-water mixture is used between the ice store and the compression refrigeration system. When charging the ice store the glycol-water mixture is cooled via a compression refrigeration system to below 0°C and thereby withdraws heat from the water in the ice store, causing the water to freeze. During discharging the melting ice withdraws heat from the glycol-water mixture causing the mixture to cool down. During this cooling process the ice store replaces or supports the compression refrigeration system.

ET 420 consists of an ice store, a refrigeration system, a circuit with glycol-water mixture, a dry and a wet cooling tower. During the evaporation of the refrigerant in the refrigeration circuit and during discharging of the ice store, heat is withdrawn from the mixture, whereas during the condensing of the refrigerant heat is added. As required the cooling towers add heat to or withdraw heat from the mixture.

The record of all required variables enables an energy balance for the individual processes. The measured values are read from digital displays and can be transmitted simultaneously via USB directly to a PC where they can be analysed using the software included.

Learning objectives/experiments

- design and operation of an energy-efficient refrigeration system
- function and operation of an ice store
 - ▶ charge
 - ▶ discharge
- energy flow balance
- energy transport via different media
- compression refrigeration cycle in the log p-h diagram
- function and operation of a wet cooling tower
- function and operation of a dry cooling tower

ET 420

Ice stores



1 displays and controls, 2 pump, 3 manometer, 4 flow meter, 5 evaporator, 6 condenser, 7 compressor, 8 ice store, 9 3-way valve, 10 compensation tank (glycol-water mixture)

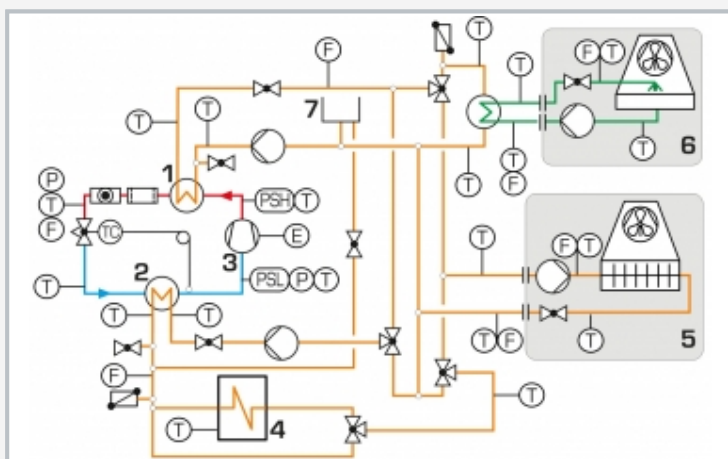

1 evaporator, 2 condenser, 3 compressor, 4 ice store, 5 dry cooling tower, 6 wet cooling tower, 7 compensation tank; pipes: green: water, blue/red: refrigerant, orange: glycol-water mixture

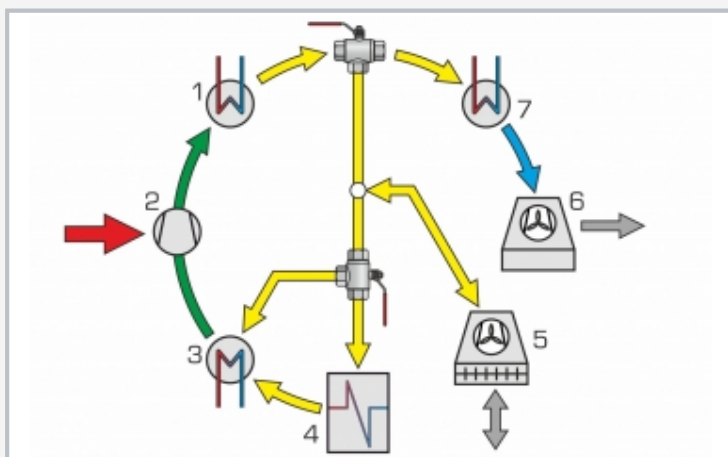

Energy flows in the system: 1 condenser, 2 compressor, 3 evaporator, 4 ice store, 5 dry cooling tower, 6 wet cooling tower, 7 heat exchanger to wet cooling tower; blue: water, yellow: glycol-water mixture, green: refrigerant, grey: air, red: electric power

Specification

- [1] investigation of the charging and discharging of an ice store
- [2] system with ice store, compression refrigeration system, dry and wet cooling towers
- [3] refrigeration circuit for R134a with compressor, condenser, evaporator and expansion valve
- [4] glycol-water circuits with pumps: cooling of the refrigerant condenser, heating of the refrigerant evaporator, charging/discharging of the ice store, operation of the dry cooling tower
- [5] water circuit with pump to operate the wet cooling tower
- [6] measurement of all relevant temperatures, pressures, flow rates and power consumption to balance the processes
- [7] GUNT software for data acquisition via USB under Windows 7, 8.1, 10

Technical data

Compressor, refrigeration capacity: approx. 1,7kW at -15/32°C

Pumps (glycol-water mixture)

■ max. flow rate: 4,5m³/h

■ max. head: 5,6m

Pump wet cooling tower (water)

■ max. flow rate: 4,5m³/h

■ max. head: 18m

Ice store: 150L

Compensation tank: 20L

Wet cooling tower, rated cooling capacity: 12kW

Dry cooling tower, rated cooling capacity: 13,8kW

Measuring ranges

■ temperature: 12x -20...100°C, 4x -50...150°C, 4x 0...60°C

■ pressure: 1x -1...9bar, 1x -1...24bar

■ flow rate: 3x 100...1200L/h, 2x 60...1500L/h, 1x 150...1600L/h, 1x 10...100L/h (R134a)

■ power: 0...2250W

230V, 50Hz, 1 phase

230V, 60Hz, 1 phase

230V, 60Hz, 3 phases

LxWxH: approx. 2200x790x1900mm (trainer)

LxWxH: approx. 1250x790x1700mm (wet cool. tower)

LxWxH: approx. 1600x900x1140mm (dry cool. tower)

Weight: approx. 650kg (in total)

Required for operation

water connection

ventilation, exhaust air

PC with Windows recommended

Scope of delivery

trainer, 1 wet cooling tower, 1 dry cooling tower, 1 set of hoses, 1 GUNT software CD + USB cable, 1 packing unit glycol, 1 set of instructional material