

## ET 426

### Capacity control in refrigeration systems



The illustration shows a similar unit.

#### Learning objectives/experiments

- key devices for changing the refrigeration capacity
  - ▶ thermostat
  - ▶ evaporation pressure controller
  - ▶ refrigeration controller
  - ▶ capacity controller
  - ▶ compressor with variable speed
- operation of a refrigeration controller with specification of temperatures for
  - ▶ controlling the refrigeration capacity
  - ▶ switching the defrost heater on and off
  - ▶ switching the fans on and off

#### Description

- examination of different capacity control methods
- open compressor with variable speed
- adjustable cooling load via heater
- controlled defrosting with temperature specification

The efficient control of the capacity and temperature in refrigeration systems is an important topic in refrigeration engineering. With ET 426 different methods of capacity control can be investigated. For this purpose a refrigeration circuit with two refrigeration chambers is available in which a cooling load is generated using an adjustable heater. Fans in both refrigeration chambers ensure an even temperature distribution.

In the first refrigeration chamber a thermostat with solenoid valve and an evaporation pressure controller control the pressure of the refrigerant in the evaporator and thereby the temperature.

Sensors record the temperature in the second refrigeration chamber and the temperature of the refrigerant upstream and downstream of the evaporator. A refrigeration controller processes the signals from the sensors. Via a solenoid valve the refrigeration controller changes the refrigerant flow in the evaporator and controls thereby the temperature in the second refrigeration chamber. The temperatures at which the fans and a defrost heater are switched on or off are also set at the refrigeration controller.

In addition the refrigeration capacity of the overall refrigeration circuit can be adjusted via the speed of the compressor. There also is the option to adjust the refrigeration capacity at a capacity controller in the compressor by-pass.

Both refrigeration chambers feature a window to be able to monitor the fan operation and formation of ice. Manometers enable the easy reading of pressures at the relevant points.

# ET 426

## Capacity control in refrigeration systems

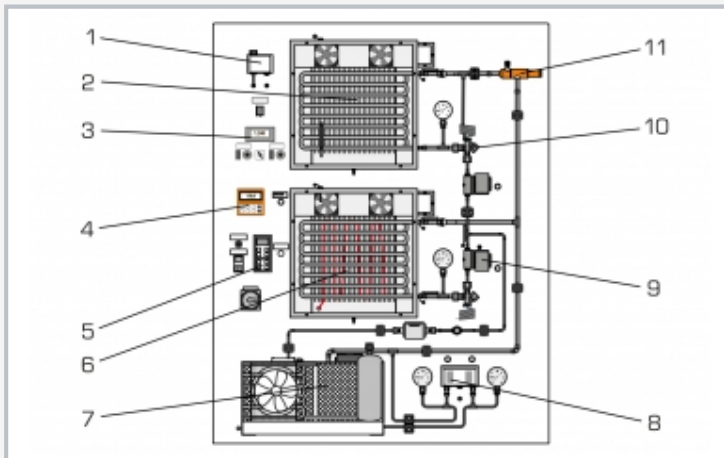

1 thermostat, 2 refrigeration chamber with heater and fan, 3 heater controls, 4 refrigeration controller, 5 compressor controls, 6 refrigeration chamber with heater, fan and defrost heater, 7 compressor and condenser, 8 combined pressure switch, 9 solenoid valve, 10 expansion valve, 11 evaporation pressure controller

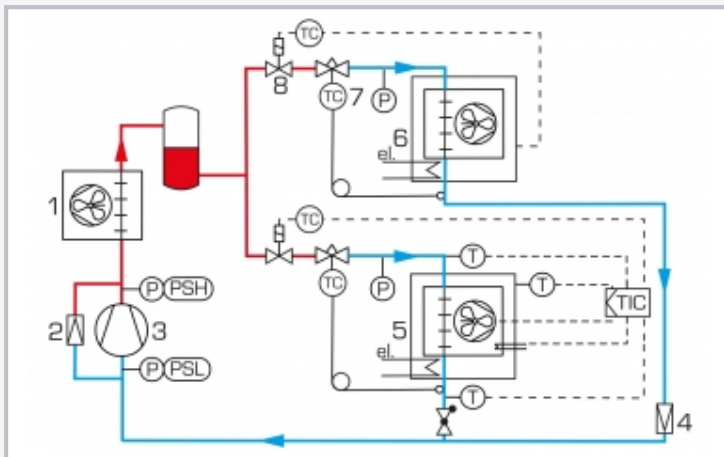

1 condenser, 2 capacity controller, 3 compressor, 4 evaporation pressure controller, 5 refrigeration chamber with heater, fan and defrost heater, 6 refrigeration chamber with heater and fan, 7 expansion valve, 8 solenoid valve with thermostat; T temperature, P pressure; PSH, PSL pressure switch, TIC refrigeration controller

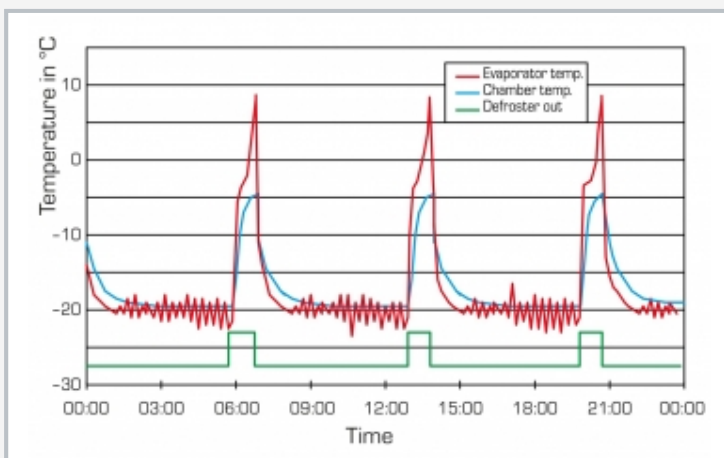

Time progression of a defrost controller (green) with temperature of evaporator (red) and refrigeration chamber (blue)

### Specification

- [1] methods for capacity control in refrigeration systems
- [2] refrigeration circuit with compressor, condenser and 2 evaporators in insulated refrigeration chambers
- [3] each refrigeration chamber with adjustable heater to generate a cooling load, thermostatic expansion valve and fan
- [4] 1 refrigeration chamber with refrigeration controller for temperature control; solenoid valve, fan and defrost heater as actuators
- [5] 1 refrigeration chamber with thermostat, solenoid valve and evaporation pressure controller for temperature control
- [6] compressor with variable speed via frequency converter
- [7] capacity controller in the compressor bypass
- [8] refrigerant R134a, CFC-free

### Technical data

#### Compressor

- refrigeration capacity: approx. 560W at -5/25°C and 1450min<sup>-1</sup>
- drive motor: 550W

2 heaters: approx. 500W

4 fans: max. volumetric air flow rate: approx. 36,5m<sup>3</sup>/h

1 defrost heater: approx. 75W

#### Refrigeration controller

- 3 inputs
- 3 outputs

Evaporation pressure controller: 0...5,5bar

Thermostat: -5...20°C

Capacity controller: 0,2...6bar

#### Measuring ranges

- compressor speed: 465...975min<sup>-1</sup>
- temperature: 3x -60...50°C
- heater power: 2x 0...1000W
- pressure: 3x -1...9bar; 1x -1...24bar

230V, 50Hz, 1 phase

230V, 60Hz, 1 phase

LxWxH: 1100x750x1900mm

Weight: approx. 150kg

### Scope of delivery

- 1 trainer
- 1 set of instructional material