

# ET 428

## Energy efficiency in refrigeration systems



The illustration shows a similar unit.

### Learning objectives/experiments

- variables affecting energy efficiency
  - ▶ controller parameters
  - ▶ refrigerant supercooling
- interconnected operation of compressors
- operation of a multicompressor controller
- methods for returning oil in a multicompressor refrigeration system
- representation of the thermodynamic cycle in the log p-h diagram

### Description

- refrigeration system with three compressors in interconnected operation
- ideal adaptation to the capacity requirement by adding and removing individual compressors
- industrial multicompressor controller to add and remove the individual compressors
- add-on heat exchanger for refrigerant supercooling
- monitoring of the lubrication oil transport in the refrigeration circuit

The efficient use of energy in refrigeration is an important topic. A higher capacity requirement is implemented in industry by connecting several small compressors in parallel. This permits the optimum adaptation to the capacity requirement by adding and removing compressors.

ET 428 includes three compressors connected in parallel for this purpose which can be switched on or off via a controller.

The components of a refrigeration circuit with three compressors are arranged clearly in the trainer. A glycol-water circuit with pump and tank with heater serves as cooling load at the evaporator. An internal heat exchanger in the refrigeration circuit allows for the refrigerant supercooling to be examined for process efficiency. The quantitative analysis of the efficiency takes place using an energy balance in the glycol-water circuit and by measuring the electrical power of the compressors.

To protect the three compressors, the refrigeration circuit is equipped with a combined pressure switch for the delivery and intake sides. To ensure a secure oil supply to the three compressors, an oil separator is provided on the delivery side of the compressors. The separated oil is returned to the compressors on the intake side. The oil is monitored through sight glasses in the respective lines.

Relevant measured values are recorded by sensors. The measured values can be read on digital displays. At the same time, the measured values can also be transmitted directly to a PC via USB. The data acquisition software is included.

# ET 428

## Energy efficiency in refrigeration systems

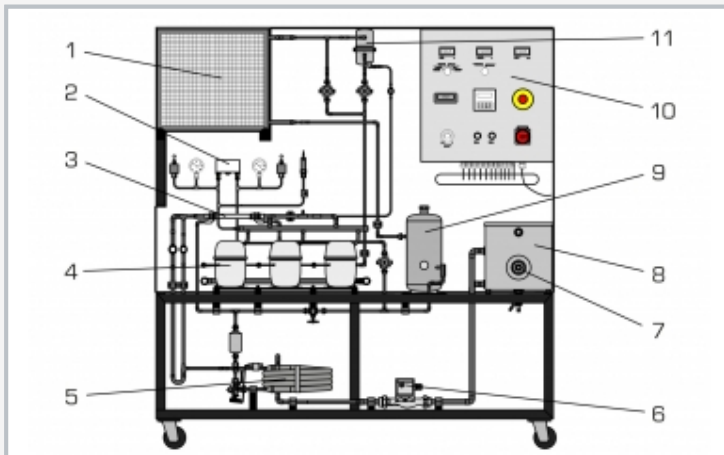

1 condenser, 2 pressure switch, 3 heat exchanger, 4 compressor, 5 evaporator, 6 pump, 7 heater, 8 cooling tank (cooling load), 9 receiver, 10 switch cabinet, 11 oil separator

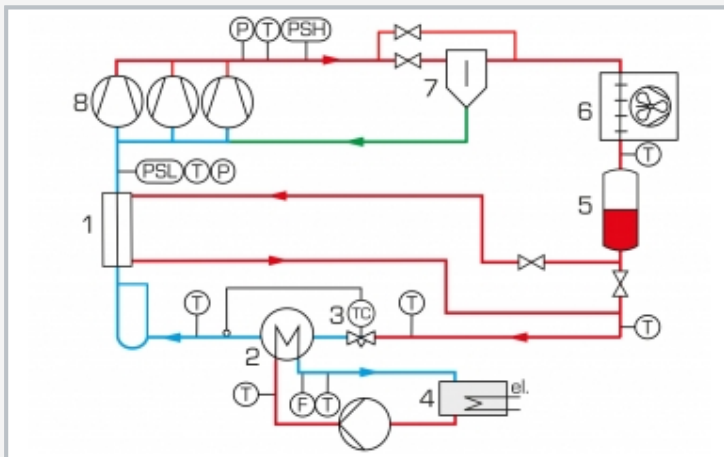

1 heat exchanger, 2 evaporator, 3 expansion valve, 4 cooling tank with heater (cooling load), 5 receiver, 6 condenser, 7 oil separator, 8 compressor; T temperature, P pressure, F flow rate, PSH, PSL pressure switch; blue: low pressure, red: high pressure, green: oil return

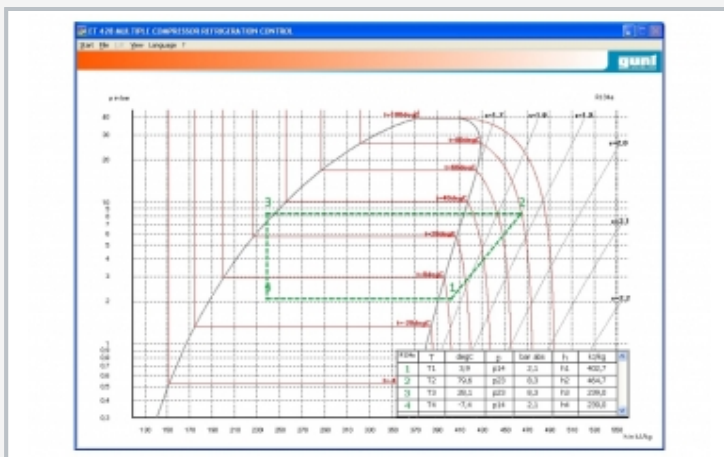

Software screenshot: log p-h diagram

### Specification

- [1] refrigeration system in multicompressor operation to investigate energy efficiency
- [2] refrigeration circuit with 3 compressors connected in parallel, condenser, thermostatic expansion valve and coaxial coil heat exchanger as evaporator
- [3] heat exchanger for refrigerant supercooling can be added via valves
- [4] glycol-water circuit includes pump and tank with heater serving as cooling load at the evaporator
- [5] multicompressor controller for the parallel operation of the compressors
- [6] separation of oil from the refrigerant on the delivery side and return to the intake side of the compressors
- [7] fan at the condenser with adjustable speed
- [8] GUNT software with control functions and data acquisition via USB under Windows 7, 8.1, 10
- [9] Refrigerant R134a, CFC-free

### Technical data

- 3 compressors
  - refrigeration capacity: each 1584W at -10°C/55°C
  - power consumption: each 1156W at -10°C/55°C
- Condenser with fan
  - capacity: 4100W
  - volumetric air flow rate: 1250m<sup>3</sup>/h
- Coaxial coil heat exchanger capacity
  - 4kW at ΔT=9K; 0,6m<sup>3</sup>/h glycol-water mixture
- Glycol-water mixture pump
  - max. flow rate: 4,2m<sup>3</sup>/h
  - max. head: 5,6m
- Heater power: 3kW
- Tank
  - glycol-water mixture: 23L
  - refrigeration circuit receiver: 5,8L

### Measuring ranges

- temperature: 4x 0...100°C, 4x -100°C...100°C
- pressure: 1x -1...9bar, 1x -1...24bar
- flow rate: 1x 1...25L/min
- power: 0...4995W (compressor)

400V, 50Hz, 3 phases  
 400V, 60Hz, 3 phases; 230V, 60Hz, 3 phases  
 UL/CSA optional  
 LxWxH: 1810x710x1920mm  
 Weight: approx. 265kg

### Required for operation

PC with Windows recommended

### Scope of delivery

- 1 trainer
- 1 GUNT software CD + USB cable
- 1 set of instructional material