

# ET 430

## Refrigeration system with two-stage compression



### Description

- **compression refrigeration system with two-stage compression to achieve particularly low temperatures**
- **injection intercooling**
- **heat exchanger for additional refrigerant supercooling**
- **real-time representation of the process in the log p-h diagram of the software**

Refrigeration systems with two-stage compression are used for the generation of particularly low temperatures. At very low temperatures large pressure differences are required between the evaporator and condenser. In a compressor the volumetric efficiency drops significantly at high pressure ratios.

Therefore, two compressors are connected in series, with each compressor only having a relatively low pressure ratio. This makes a more favourable dimensioning of the low pressure stage compressor possible. Due to the large specific volume it requires a larger capacity at lower drive power.

In addition, intercooling between the low pressure compressor (LP) and the high pressure compressor (HP) reduces the

outlet temperature of the HP compressor to harmless values and improves the efficiency of the compression.

The trainer ET 430 uses injection intercooling. A small amount of liquid refrigerant is injected from the receiver into the outlet line of the LP compressor. The liquid refrigerant evaporates and thus cools the intake gas for the HP compressor. Via an add-on heat exchanger in the injection cooler the supercooling of the liquid refrigerant can be increased upstream of the expansion valve. This allows for an increase in the evaporator capacity.

Valves allow for the injection intercooling or the heat exchanger for refrigerant supercooling to be switched off. This can demonstrate their effect on the system.

All relevant measured values are recorded by sensors and displayed. The simultaneous transmission of the measurements to the GUNT software enables analysis and the representation of the process in the log p-h diagram in real time. Additionally, two flow meters indicate the total volumetric flow rate and the volumetric flow rate in the intercooling.

### Learning objectives/experiments

- design and function of a refrigeration system with two-stage compression and injection intercooling
- effect of the inlet temperature at the HP compressor on the efficiency of the compression
  - ▶ with intercooling
  - ▶ without intercooling
- effect of the additional refrigerant intercooling
- distribution of the compressor pressure ratios
- represent and understand the refrigeration cycle process in the log p-h diagram

# ET 430

## Refrigeration system with two-stage compression



1 expansion valve, 2 refrigeration chamber, 3 displays and controls, 4 pressure switch, 5 injection valve, 6 injection cooler, 7 LP compressor, 8 HP compressor, 9 receiver, 10 flow meter, 11 heat exchanger, 12 condenser

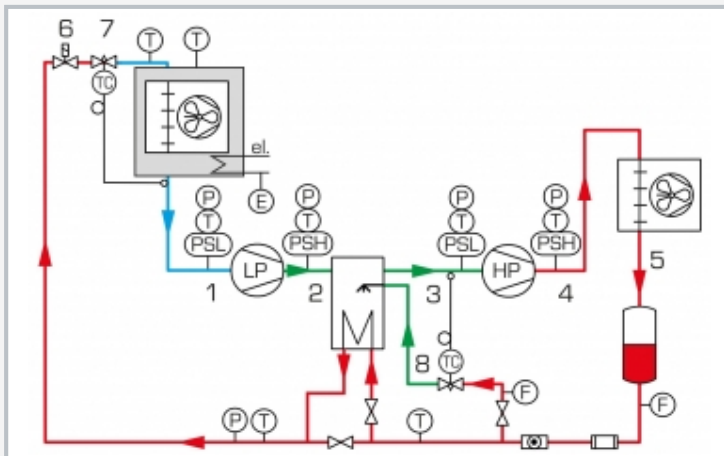

1-2 LP compression, 2-3 intercooling, 3-4 HP compression, 4-5 condensation, 5-6 supercooling, 6-7 expansion, 7-1 evaporation;  
T temperature, P pressure, E electrical power, F flow rate, PSL, PSH pressure switch

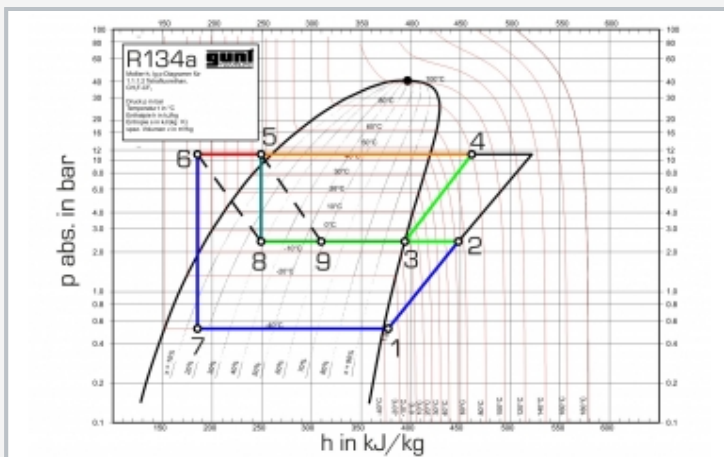

log p-h diagram of a two-stage refrigeration system with injection intercooling (for process steps see process schematic)

### Specification

- [1] refrigeration system with two-stage compression
- [2] hermetic low and high pressure compressors
- [3] adjustable intercooling via refrigerant injection
- [4] heat exchange for additional supercooling of the liquid refrigerant
- [5] closed refrigeration chamber contains evaporator with fan and adjustable electric heater as cooling load
- [6] digital display for temperatures, drive power of the compressors and cooling load power
- [7] real-time representation of the process in the log p-h diagram of the software
- [8] GUNT software for data acquisition via USB under Windows 7, 8.1, 10
- [9] refrigerant R404a, CFC-free

### Technical data

Low pressure compressor (LP)  
 ■ displaced volume: 25,93cm<sup>3</sup>  
 ■ power consumption: 550W  
 ■ refrigeration capacity: 1744W at -10/32°C

High pressure compressor (HP)  
 ■ displaced volume: 8,86cm<sup>3</sup>  
 ■ power consumption: approx. 275W  
 ■ refrigeration capacity: 583W at -10/32°C

#### Measuring ranges

- flow rate: 1x 2...29L/h, 1x 4...40L/h
- pressure: 1x -1...15bar, 2x -1...24bar
- temperature: 8x -75...125°C
- power:
  - ▶ 1x 0...562W (heater)
  - ▶ 1x 0...750W (LP compressor)
  - ▶ 1x 0...2250W (HP compressor)

230V, 50Hz, 1 phase  
 230V, 60Hz, 1 phase  
 230V, 60Hz, 3 phases  
 UL/CSA optional  
 LxWxH: 1900x790x1900mm  
 Weight: approx. 283kg

### Required for operation

PC with Windows recommended

### Scope of delivery

- 1 trainer
- 1 GUNT software CD + USB cable
- 1 set of instructional material