

ET 915.01

Refrigerator model



Description

- simple model of a domestic refrigerator for connection to the ET 915
- component operation and fault simulation via the GUNT software

ET 915.01 is part of the HSI training system for refrigeration and air conditioning technology. In combination with the base unit ET 915 the operational model of a domestic refrigerator is created. The model is plugged onto the base unit, secured using fasteners and connected with refrigerant hoses to become a complete refrigeration circuit.

ET 915.01 consists of a refrigeration chamber with a heater as cooling load, evaporator, fan and various expansion elements. The fan supports the achievement of an even temperature distribution in the chamber. A cooling load can additionally be simulated with the heater. Solenoid valves enable the operation of the system with capillary tube or with expansion valve. All components are clearly arranged on a panel.

The operation of individual system components, here the temperature control, fan, heater, compressor and solenoid valves, takes place via the software. The software offers the option to simulate faults.

Temperatures and pressures in the system are recorded by sensors and displayed dynamically in the software. The effect of parameter changes can be tracked online in the log p-h diagram. Fundamentals and individual components are represented in the educational software for ET 915.01. Performance assessments check the learning progress. With the aid of the authoring system further exercises and performance assessments can be created.

Learning objectives/experiments

- understand and get familiar with the design and operation of a simple refrigeration system
- familiarisation with the principle of operation of an evaporator
- different expansion elements
 - ▶ operation with capillary tube
 - ▶ operation with expansion valve
- operating behaviour under load
- refrigeration cycle in the log p-h diagram
- fault simulation

ET 915.01

Refrigerator model

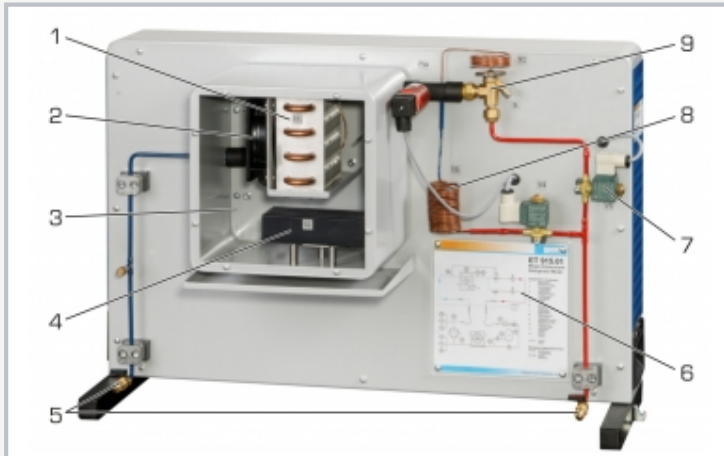

1 evaporator, 2 fan, 3 refrigeration chamber, 4 heater, 5 connections to ET 915, 6 process schematic, 7 solenoid valve, 8 capillary tube, 9 expansion valve

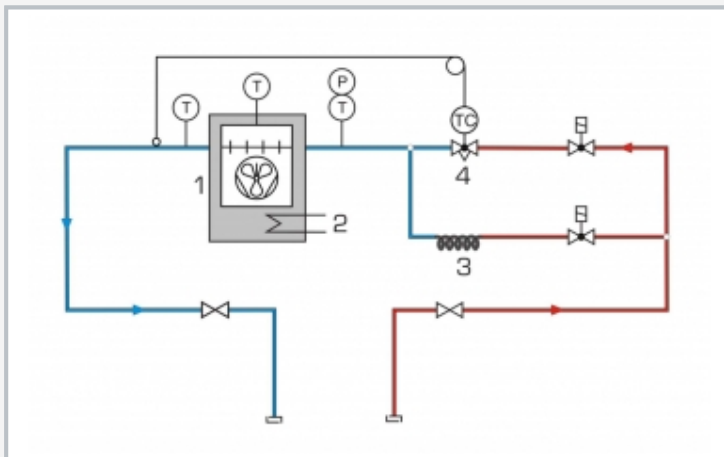

Process schematic of the refrigerator model: 1 evaporator, 2 heater, 3 capillary tube, 4 expansion valve; T temperature, P pressure; blue: low pressure, red: high pressure

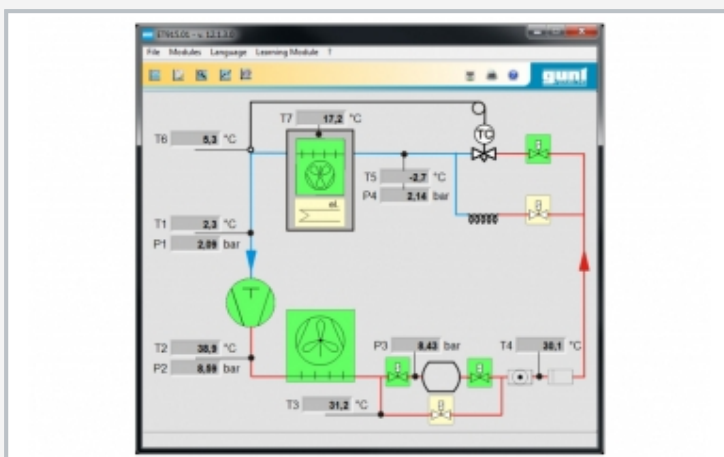

Software screenshot: process schematic

Specification

- [1] model of a refrigerator to plug onto the base unit ET 915
- [2] GUNT training system with HSI technology
- [3] refrigeration chamber with evaporator, fan and cooling load
- [4] chamber with transparent front
- [5] electric heater to generate the cooling load
- [6] expansion elements selectable via solenoid valves: expansion valve or capillary tube
- [7] sensors to record temperature and pressure
- [8] operation of solenoid valves, fan, heater and fault simulation via software
- [9] GUNT software for data acquisition via USB under Windows 7, 8.1, 10
- [10] GUNT software: educational software, data acquisition, system operation

Technical data

Refrigeration chamber, LxWxH: 270x270x220mm
 Electric PTC heater as cooling load: 210W
 Capillary tube: length 2m

Measuring ranges
 ■ temperature: 3x -50...50°C
 ■ pressure: -1...9bar

LxWxH: 850x380x550mm
 Weight: approx. 30kg

Scope of delivery

- 1 refrigerator model, filled with refrigerant
- 1 GUNT software CD + USB cable

ET 915.01

Refrigerator model

Required accessories

061.91500 ET 915 HSI training system refrigeration and air conditioning technology, base unit