

FL 170

Deformation of curved-axis beams



Learning objectives/experiments

- bending behaviour of a curved-axis beam
 - ▶ circular beam
 - ▶ semi-circular beam
 - ▶ quadrant beam
- application of the principle of virtual forces (the force method) to calculate deformation
- second moment of area
- comparison of calculated and measured deformations

Description

- **elastic deformation of curved-axis beams**
- **circular, semi-circular and quadrant beams**

In construction engineering, a distinction is made between beams and arches. An arch is a statically indeterminate supported structure with a curved axis and two fixed supports or clamp fixings. The supports of an arch (such as a double-articulated arch) absorb forces vertically and horizontally. The ends of the arch in the supports do not move. This produces the static arching effect of the system. In mechanical engineering, crane hooks and chain links are typical examples of a curved beam.

FL 170 includes three different beams, borne on statically determinate supports: a circular beam, a semi-circular beam and a quadrant beam.

The beam under test is loaded with weights. Dial gauges record its horizontal and vertical deformations.

All three beams have the same cross-section and so the same second moment of area. This enables test results to be directly compared. Semi-circular and circular beams are fixed to a support on the pillar. The quadrant beam is clamped into a support block.

The various elements of the experiment are clearly laid-out and housed securely in a storage system.

FL 170

Deformation of curved-axis beams

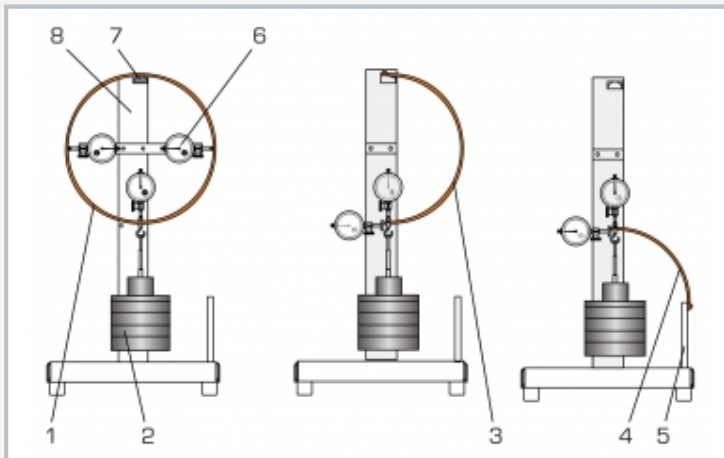

1 circular beam, 2 weight, 3 semi-circular beam, 4 quadrant beam, 5 support block, 6 dial gauge, 7 support, 8 pillar

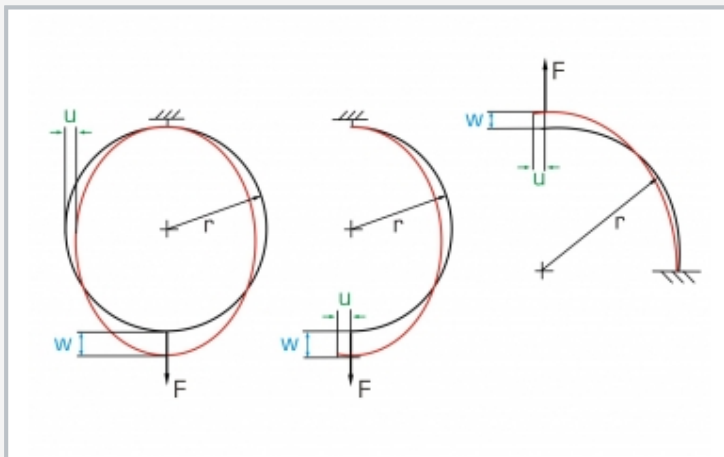

Deformations on curved-axis beams under tensile load:
F force, r radius, u horizontal displacement, w vertical displacement

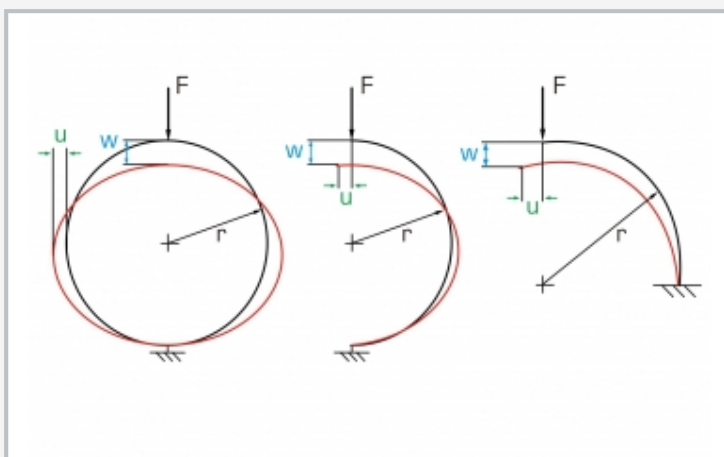

Deformations on curved-axis beams under compressive load:
F force, r radius, u horizontal displacement, w vertical displacement

Specification

- [1] elastic deformation of curved-axis beams under load
- [2] 3 different beams with the same cross-section: circular beam, semi-circular beam, quadrant beam
- [3] support block to fix the quadrant beam
- [4] pillar with support for mounting the circular or semi-circular beam
- [5] 3 dial gauges to record the horizontal and vertical deformation
- [6] storage system to house the components

Technical data

Curved-axis beam

- radius: approx. 150mm
- cross-section WxH: 20x5mm
- material: steel, galvanised

Dial gauges

- measuring range: 0...20mm
- graduation: 0,01mm

Weights

- 1x 1N (hanger)
- 2x 2N
- 1x 5N
- 1x 10N
- 4x 20N

LxWxH: 400x300x650mm

Weight: approx. 21kg

LxWxH: 1170x480x178mm (storage system)

Scope of delivery

- 1 base plate with pillar
- 3 beams
- 3 dial gauges
- 1 set of weights
- 2 hexagon socket wrenches
- 1 storage system with foam inlay
- 1 set of instructional material

FL 170

Deformation of curved-axis beams

Optional accessories

020.30009 WP 300.09 Laboratory trolley