

HL 320.07

Underfloor heating / geothermal energy absorber



Description

- **trainer for the HL 320 “Solar thermal energy and heat pump” system**
- **can be used as heat sink or heat source**
- **option for heat transfer pipes in various lengths**
- **temperature and flow sensors for connection to the HL 320.05 controller module**

Underfloor heaters transfer heat by piping systems arranged in a spiral or winding pattern beneath the floor covering. Underfloor heating requires much lower feed flow temperature than conventional radiators. Underfloor heating systems are particularly well suited for use with heating systems that use solar thermal collectors.

Besides its function as a heat sink when used as an underfloor heating system, the HL 320.07 trainer can also be used as a heat source for a heat pump in the HL 320 modular system. In this case, the direction of the heat transport is reversed.

HL 320.07 is equipped with three individually selectable piping systems of different lengths. The pipes are surrounded by a tank which can be filled with water if necessary. Sensors are mounted on the piping system to detect the temperature on the feed and return.

Heat quantities and energy balances can be calculated using these temperatures together with the measurement data from the integrated flow meter.

Carefully structured instructional materials have been created for the intended modular combinations with the HL 320.07 module. As part of the documentation for the HL 320 modular system, these materials set out the basic principles and provide a step-by-step guide through the experiments.

Learning objectives/experiments

- **energy balance in combined heating systems for domestic hot water production and heating**
- **heat transfer in an underfloor heating system**
- **use of heat sources for heat pump systems**
- **learning objectives of the HL 320 modular system**

HL 320.07

Underfloor heating / geothermal energy absorber

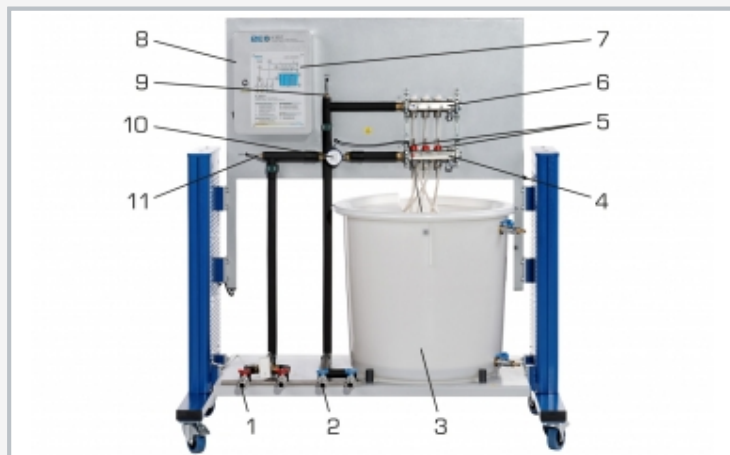

1 connection for feed, 2 connection for return, 3 tanks for hot and cold water, 4 feed distributor, 5 flow meter, 6 return distributor, 7 info panel, 8 connection box for sensors, 9 return temperature sensor, 10 flow meter, 11 return temperature sensor

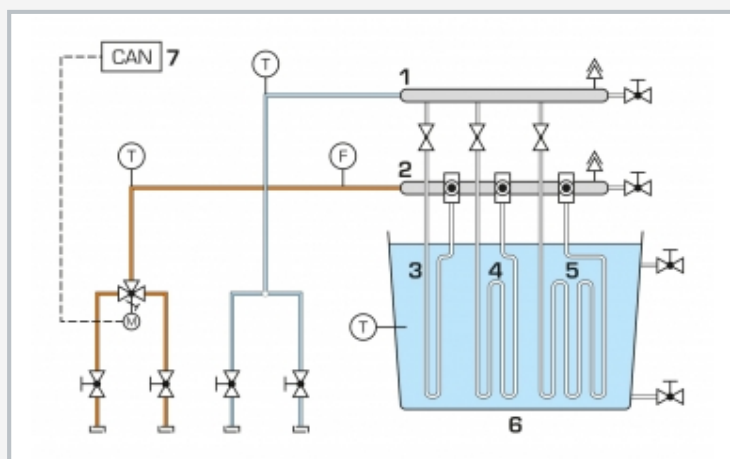

1 return distributor, 2 feed distributor, 3 10m piping circuit, 4 20m piping circuit, 5 30m piping circuit, 6 tanks for experiments with hot and cold water, 7 CAN bus; T temperature, F flow rate

	1	2	3	4	5
HL 320.01			X	X	X
HL 320.02		X			X
HL 320.03	X	X		X	X
HL 320.04	(X)	(X)		(X)	(X)
HL 320.05	X	X		X	X
HL 320.07		X	X	X	X
HL 320.08			X	X	X

Recommended combinations of the HL 320 modular system

Specification

- [1] heat sink or heat source for the HL 320 modular system
- [2] 3 selectable pipe lengths for heat transfer
- [3] flow meters and temperature sensors for determining the heat flows
- [4] tanks for hot or cold water
- [5] connections for transmitting measurement data to an external controller

Technical data

Pipes

- lengths: 10m, 20m, 30m
- material: polyethylene
- wall thickness: 2mm
- outer diameter: 16mm
- operating pressure: max. 3bar

Tank

- volume: 200L

Measuring ranges

- temperature: 3x -50...180°C
- flow rate: 30...1000L/h

LxWxH: 1500x 800x1700mm

Weight: approx. 95kg

Scope of delivery

- 1 trainer
- 1 manual

HL 320.07

Underfloor heating / geothermal energy absorber

Required accessories

Combination 2

065.32002	HL 320.02	Conventional heating
065.32003	HL 320.03	Flat plate collector
065.32005	HL 320.05	Central storage module with controller

Combination 3

065.32001	HL 320.01	Heat pump
065.32008	HL 320.08	Fan heater / air heat exchanger

Combination 4

065.32001	HL 320.01	Heat pump
065.32003	HL 320.03	Flat plate collector
065.32005	HL 320.05	Central storage module with controller
065.32008	HL 320.08	Fan heater / air heat exchanger

Combination 5

065.32001	HL 320.01	Heat pump
065.32002	HL 320.02	Conventional heating
065.32003	HL 320.03	Flat plate collector
065.32005	HL 320.05	Central storage module with controller
065.32008	HL 320.08	Fan heater / air heat exchanger

Optional accessories

Combination 2, 4, 5

065.32004	HL 320.04	Evacuated tube collector
065.31301	HL 313.01	Artificial light source