

HL 960.01

Assembly and alignment of pumps and drives



Learning objectives/experiments

- installing a pump in a system
- connecting and aligning motor and pump
- familiarisation with various alignment methods:
 - ▶ straight edge, dial gauges
- familiarisation with key system components
- electrical installation of motor and switching elements
- assembly of pipes and instrumentation
- detail installation on a standard centrifugal pump
- reading and understanding engineering drawings, product documentation and circuit diagrams
- familiarisation with maintenance procedures
- planning assembly and maintenance steps
- in conjunction with HL 960
 - ▶ operational testing in a pipe network

Description

- installing a pump in a system
- alignment of electric motor and pump by different methods

A complete work process when repairing work machines such as pumps consists of the following steps: assembly – alignment – test. The trainer described here was designed with industrial conditions in mind and is primarily intended for the practical training of maintenance engineers. It also offers a variety of topics and starting points for training in vocational schools.

The HL 960.01 trainer enables students to practise the entire maintenance process. On its own, the trainer can be used for assembly exercises with the option of aligning the drive and the pump. Combined with HL 960 Assembly station: pipes and valves and fittings, the HL 960.01 trainer can be used as a test system for the completely assembled piping system.

The trainer consists of an electric drive motor, a standard pump and a piping system with storage tank and can be operated independent of the water supply mains. Students can practise exchanging pumps for inspection or repair as part of the assembly exercise. The exercises cover the entire system and its individual subassemblies. A manometer displays the pressure at the outlet of the pump.

The position of the electric motor can be adjusted in three directions for alignment purposes. The alignment can either be checked in a conventional manner with a straight edge or with the reverse alignment method using two dial gauges. Non-contact, microprocessor-aided methods can also optionally be used (specific alignment systems are not included in the scope of delivery).

HL 960.01

Assembly and alignment of pumps and drives

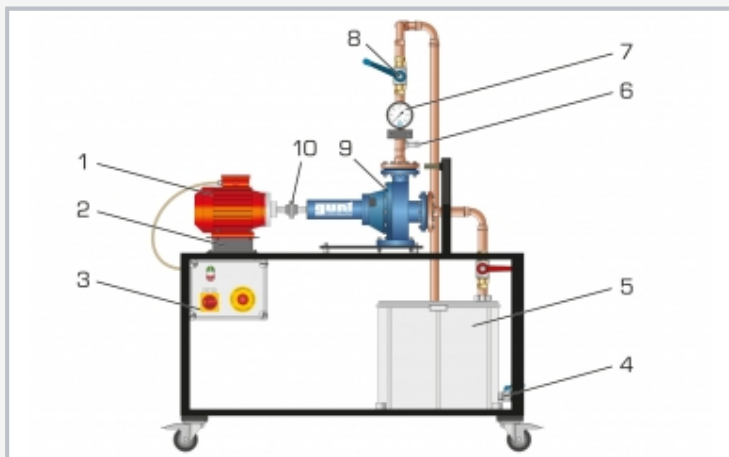

1 electric motor, 2 foundation for electric motor, 3 switch box, 4 HL 960 return connection, 5 storage tank, 6 HL 960 inlet connection, 7 manometer, 8 shut-off valve, 9 pump, 10 coupling

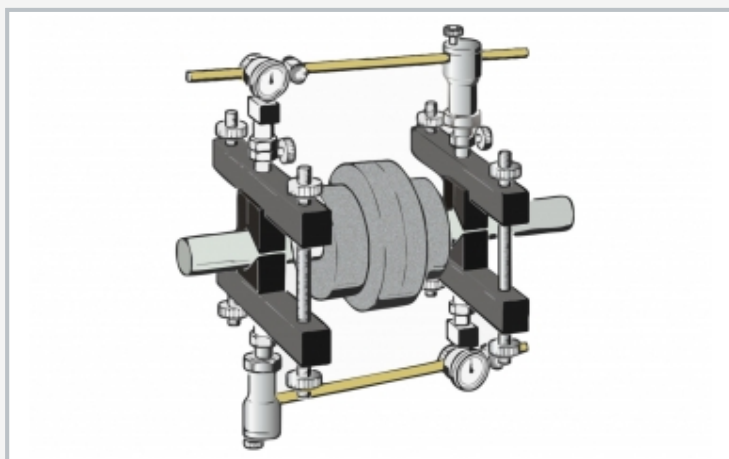

The illustration shows the principle of the dual radial dial gauge method of aligning shafts.

Specification

- [1] mobile system for alignment of a standard pump and its drive motor
- [2] asynchronous electric motor with constant speed
- [3] electric motor with positioning frame and fit plates for alignment
- [4] pump and motor connected via coupling
- [5] checking of alignment using straight-edge or dial gauges
- [6] manometer at pump outlet
- [7] pump with ball valves at inlet and outlet
- [8] closed water circuit
- [9] the system forms part of the GUNT assembly, maintenance and repair practice line

Technical data

Centrifugal pump

- max. flow rate: 300L/min
- max. head: 16,9m
- power consumption: 750W

Asynchronous motor, single phase

- power output: 1100W
- speed: 3000min⁻¹

Storage tank: 96L

Measuring ranges

- dial gauges: 0...3mm/0...20mm, resolution: 0,01mm
- manometer: 0...1,6bar

230V, 50Hz, 1 phase

230V, 60Hz, 1 phase

LxWxH: 1250x830x1520mm

Weight: approx. 122kg

Scope of delivery

- 1 trainer with centrifugal pump and drive
- 1 set of measuring aids, consisting of
 - 2 dial gauges 0...3mm,
 - straight-edge,
 - test shaft for sag measurement,
 - dial gauge with magnetic holder, 0...20mm
- 1 set of tools
- 1 set of instructional material