

HM 136

Flow through packed columns



The illustration shows a similar unit.

Learning objectives/experiments

- function of a packed column
- compare operating modes
 - ▶ with water
 - ▶ water-air operation in parallel flow
 - ▶ water-air operation in counterflow
- demonstration of
 - ▶ wall effect
 - ▶ stream formation
 - ▶ loading point
 - ▶ flooding point
- hydraulic characteristics
 - ▶ pressure loss diagram
 - ▶ holdup diagram

Description

- **transparent model of a packed column**
- **flow through the column with water or water and air**
- **parallel flow or counterflow mode**

Packed columns have a variety of uses in process engineering, waste water and air purification and in biotechnical systems. For example, in an adsorption column the two substances can be brought into close contact using the packing. When used as a fixed bed reactor, the packing carries the catalyst necessary for the reaction. Packing is available in the widest variety of shapes and materials.

Observing the desired flow conditions is vital for proper functioning. Wetting, contact time and flow resistance play a key role. These packed column properties can be studied with the HM 136 trainer, and important phenomena such as the wall effect or the flooding point can be demonstrated.

The central element of the trainer is the transparent packed column. The pressures in the top, middle and bottom of the column are measured, so that the pressure losses in the fixed bed can be determined. The column can be operated with water or water and air. When operating with water, the direction of flow can be changed, so that even a fully flooded column can be studied, such as

in a fixed bed reactor. Operating the column with water and air in counterflow simulates the application as an absorption column. The packed bed is interchangeable, so that a laboratory's own packing can also be tried out.

The experimental unit has its own air and water supply. The closed water circuit consists of storage tank, pump, flow meter and valve. The air supply includes a compressor with flow meter and valve.

HM 136

Flow through packed columns



1 digital pressure indicators, 2 air flow meter, 3 compressor for air, 4 storage tank, 5 pump for water, 6 bottom rising-falling switch valve, 7 water flow meter, 8 two-piece packed column, 9 top rising-falling switch valve

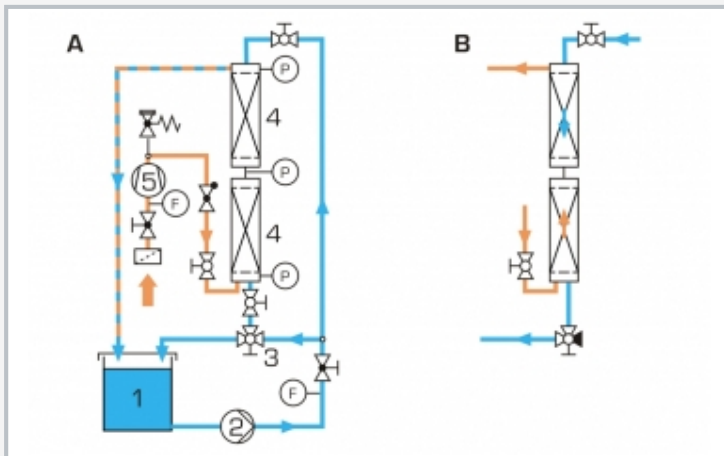

A process schematic: 1 storage tank, 2 pump, 3 switch valve, 4 packed column, 5 compressor; F flow rate, P pressure; B operating mode water falling, air rising [counterflow]

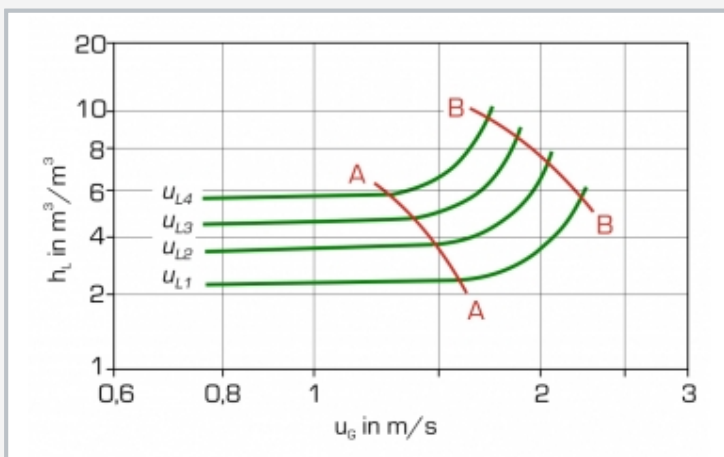

Holdup diagram: A loading point, B flooding point, h_L holdup, u_G superficial gas velocity, u_{L1-4} specific liquid load

Specification

- [1] trainer for studying the flow in packing layers
- [2] transparent DURAN glass packed column with interchangeable packed bed
- [3] operation with water or water and air
- [4] water-air operation in parallel flow or counterflow
- [5] water direction of flow can be reversed
- [6] closed water circuit with a pump and storage tank
- [7] compressor for air supply
- [8] measurement of flow rate and pressure loss

Technical data

Pump

- max. flow rate: 18L/min
- max. head: 45m
- power consumption: 250W

Compressor

- max. volumetric flow rate: 8m³/h
- max. pressure: 1bar rel.
- power consumption: 370W

Packed column

- inner diameter: 80mm
- length: 2x 500mm
- packing height: approx. 350mm

Storage tank: 55L

Measuring ranges

- flow rate (air): 1...10m³/s
- flow rate (water): 50...600L/h
- differential pressure: 2x 0...100mbar, 1x 0...300mbar

230V, 50Hz, 1 phase

230V, 60Hz, 1 phase; 120V, 60Hz, 1 phase

LxWxH: 1350x790x1980mm;

H ready for conducting experiments: 2500mm

Weight: approx. 250kg

Scope of delivery

- 1 trainer
- 1 set of accessories
- 1 set of instructional material