

HM 150.02

Calibration of pressure gauges



Description

■ operation of a Bourdon tube pressure gauge and a piston manometer

In the field of metrology, calibration describes a process for detecting deviations in a measuring instrument compared to a reference instrument or universally accepted standard value. This observed deviation is taken into account in the subsequent use of the calibrated measuring instrument and adjusted if necessary.

HM 150.02 is a device designed as an introduction to the basics of checking and calibrating a manometer.

A piston manometer is connected to a Bourdon tube pressure gauge via a pipe. Piston manometers are especially suited to producing well-defined pressures in liquids or gases and have been used for years as one of the most accurate methods for calibrating pressure gauges.

A defined force is produced by loading the piston with weights. The ratio of force / piston cross-sectional area results in a defined test pressure. Hydraulic oil is used to transfer the force. If the pressure in the system rises, the force acts against the spring of the Bourdon tube pressure gauge. The test pressure that is produced can be read on the manometer's transparent dial. The spring mechanism – and thus the way in which the Bourdon tube pressure gauge works – is clearly visible through the transparent dial.

Loading the calibrated piston manometer with weights produces a very accurate, reproducible calibration pressure, which can be used to check and calibrate the manometer.

Learning objectives/experiments

- working principle of a Bourdon tube pressure gauge
- calibrate manometers, read off applied pressure
- determine systematic errors
- principle of operation and working with a piston manometer

HM 150.02

Calibration of pressure gauges

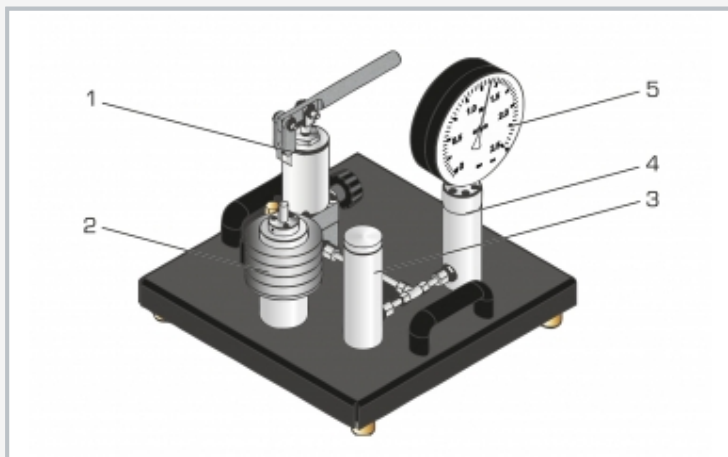

1 hydraulic pump with storage tank, 2 load weights on mount, 3 piston manometer, 4 Bourdon tube pressure gauge, 5 transparent dial

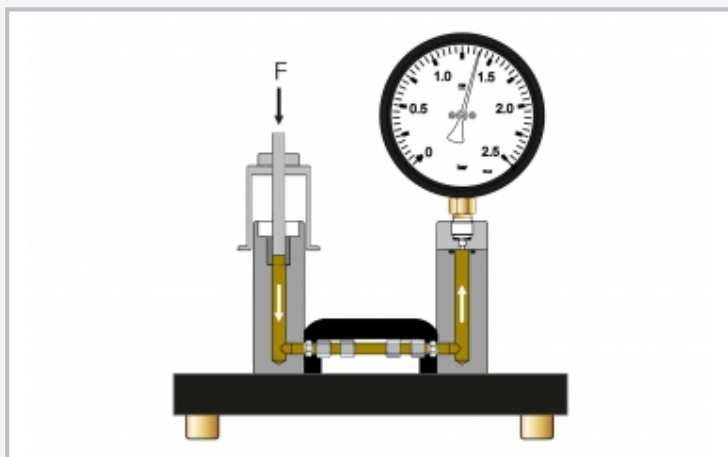

Load and pressure measurement unit are connected to each other via a pipe; when the piston is loaded the pressure in the system rises and acts against the spring on the manometer; F weight force

Specification

- [1] Bourdon tube pressure gauge for pressure measurement
- [2] transparent dial face with a view of the spring mechanism
- [3] accurately fitting piston and cylinder of the piston manometer without seals
- [4] hydraulic oil for transfer of the force
- [5] hydraulic pump with storage tank and bleed mechanism

Technical data

Piston manometer

- pressure piston: diameter: 12mm
- hydraulic cylinder: diameter: 25mm, length=225mm
- oil: ISO viscosity grade: VG 32

Set of weights

- weight holder: 385g / 0,334bar
- 1x 193g / 0,166bar
- 4x 578g / 0,5bar

Measuring ranges

- pressure: 0...2,5bar

LxWxH: 400x400x400mm

Weight: approx. 16kg

Scope of delivery

- 1 experimental unit
- 1 set of weights
- 1 oil (500mL)
- 1 set of instructional material

HM 150.02

Calibration of pressure gauges

Optional accessories

020.30009

WP 300.09

Laboratory trolley