

# HM 150.04

## Centrifugal pump



The illustration shows HM 150.04 together with HM 150.

### Description

- **characteristic curve of a centrifugal pump**
- **variable speed via frequency converter**

Centrifugal pumps are turbomachines that are used for conveying fluids. The HM 150.04 unit can be used to study a centrifugal pump and to record a typical pump characteristic curve.

The experimental unit includes a self-priming centrifugal pump, a ball valve on the outlet side and manometers on the inlet and outlet side. It is driven by an asynchronous motor. The speed is infinitely adjustable by using a frequency converter. A ball valve is used to adjust the head.

In experiments, the operating behaviour of the pump as a function of the flow rate is studied and displayed in characteristic curves. The motor's speed and electrical power are displayed digitally. Pressures on the inlet and outlet side are displayed on two manometers.

The experimental unit is positioned easily and securely on the work surface of the HM 150 base module. The pump draws in water from the tank on the base module HM 150. The flow rate is determined volumetrically by flowing back into the measuring tank on HM 150.

### Learning objectives/experiments

- recording the pump characteristic curve at a constant pump speed
  - ▶ measuring the inlet and outlet pressure
  - ▶ determining the flow rate
- recording the pump characteristics for different speeds
- power and efficiency curves
  - ▶ measuring the electrical drive power
  - ▶ determining the hydraulic power
  - ▶ calculating the efficiency

# HM 150.04

## Centrifugal pump

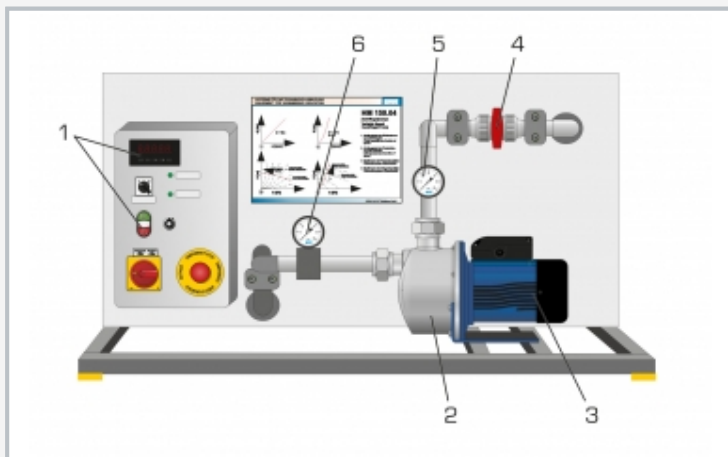

1 display and controls, 2 centrifugal pump, 3 motor, 4 ball valve for adjusting the head, 5 outlet side manometer, 6 inlet side manometer

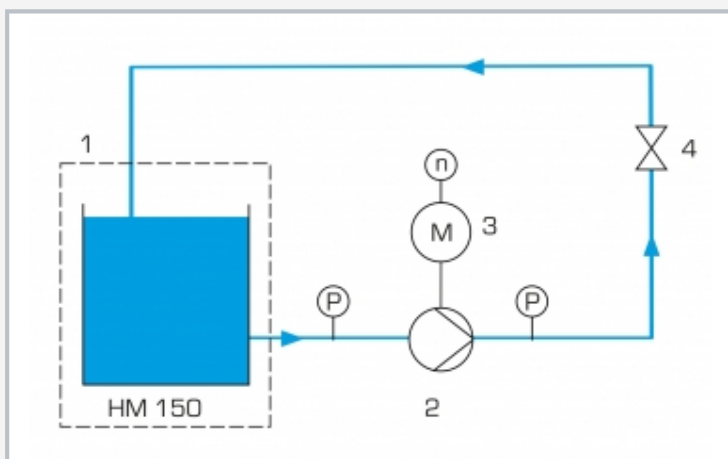

1 water supply via HM 150, 2 centrifugal pump, 3 motor, 4 ball valve for adjusting the head; P pressure, n speed

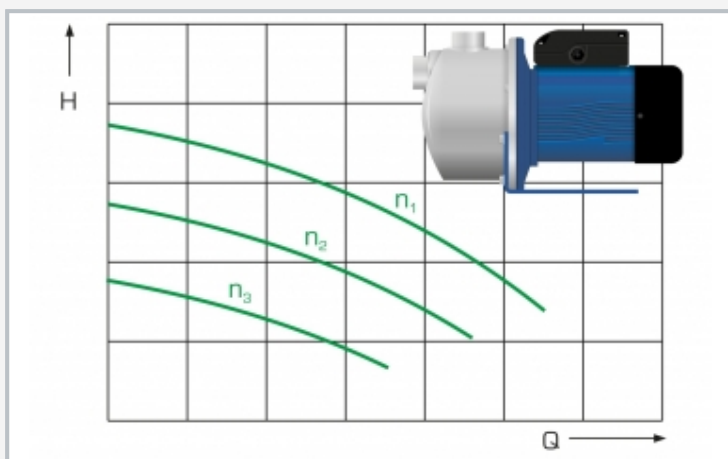

Pump characteristic curves at different speeds:  
H head, Q flow rate, n speed

### Specification

- [1] investigation of a centrifugal pump
- [2] drive with variable speed via frequency converter
- [3] ball valve to adjust the head
- [4] manometers on the inlet and outlet side of the pump
- [5] digital display of speed and power
- [6] flow rate determined by base module HM 150
- [7] water supply using base module HM 150

### Technical data

Centrifugal pump, self-priming

- max. flow rate: 3000L/h
- max. head: 36,9m

Asynchronous motor

- nominal power: 370W

Measuring ranges

- pressure (outlet side): -1...5bar
- pressure (inlet side): -1...1,5bar
- speed: 0...3000min<sup>-1</sup>
- power: 0...1000W

Measuring ranges

- pressure (outlet): -1...5bar
- pressure (inlet): -1...1,5bar
- speed: 0...3000min<sup>-1</sup>
- power: 0...1000W

230V, 50Hz, 1 phase

230V, 60Hz, 1 phase; 120V, 60Hz, 1 phase

UL/CSA optional

LxWxH: 1100x640x600mm

Weight: approx. 46kg

### Required for operation

HM 150 (closed water circuit)

### Scope of delivery

- 1 experimental unit
- 1 set of instructional material

# HM 150.04

## Centrifugal pump

Required accessories

070.15000      HM 150      Base Module for Experiments in Fluid Mechanics