

HM 150.05

Hydrostatic pressure in liquids



Description

■ determination of forces on surfaces under hydrostatic pressure

The weight of fluids at rest causes a pressure that is known as hydrostatic pressure or gravitational pressure. This pressure acts on any area that is in communication with the fluid, exerting a force that is proportional to the size of the area.

The effect of hydrostatic pressure is highly important in many fields of engineering: in shipbuilding, in hydraulic engineering when designing locks and weirs, in sanitation and building services.

The HM 150.05 experimental unit offers typical experiments to study hydrostatic pressure in liquids at rest. The effect of the hydrostatic pressure of water can be clearly shown at different water levels and angles of inclination.

The experimental unit consists of a transparent, tilting water tank with a scale for measuring volumes. Another scale is used to adjust the angle of inclination of the water tank. The device is balanced by a lever arm using different weights and the compressive force measured.

Learning objectives/experiments

- pressure distribution along an effective area in a liquid at rest
- lateral force of the hydrostatic pressure
- determination of the centre of pressure and centre of area
- determination of the resulting compressive force

HM 150.05

Hydrostatic pressure in liquids

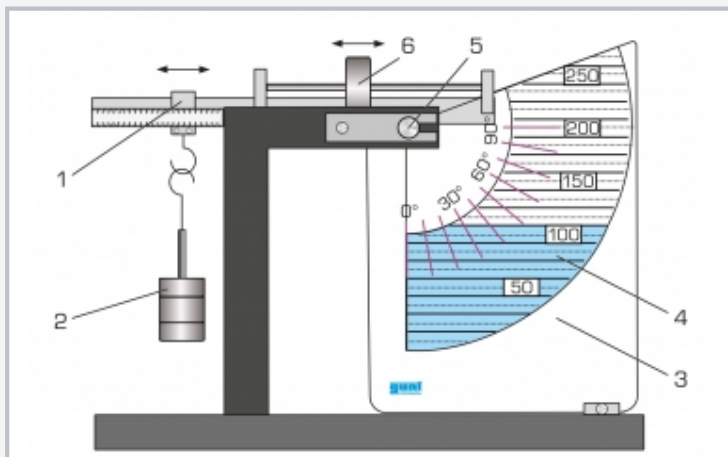

1 hanger with scale, 2 weights, 3 transparent plastic disc with angular and fill level scale, 4 water tank, 5 axis of rotation, 6 movable weight

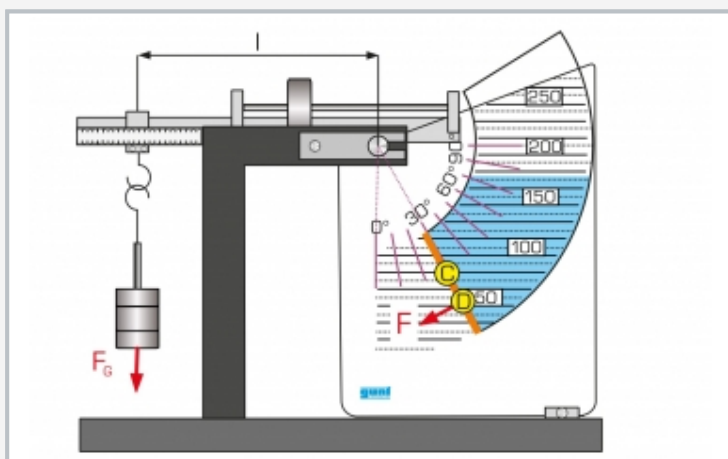

Measuring principle for different inclination angles of the water tank:
blue: water level, orange: effective area; F force, F_G weight, l lever arm of the weight, C centre of gravity of the area, D centre of pressure

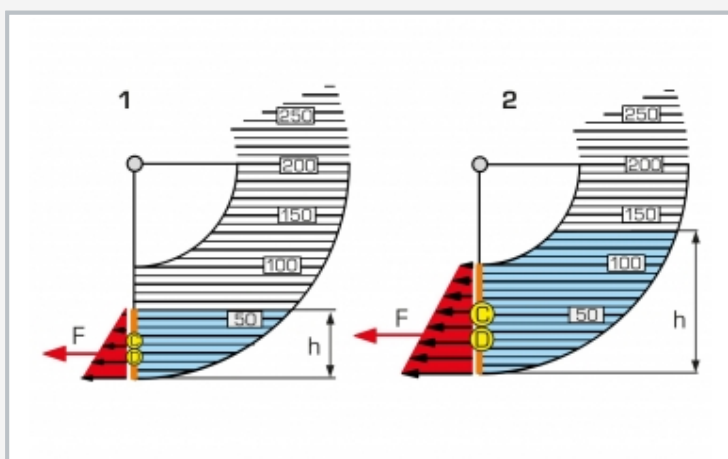

Pressure profiles at different water levels: 1 water level less than 100mm, 2 water level greater than 100mm; red: pressure profiles, orange: effective area; F force, h water level, C centre of area of the area, D centre of pressure

Specification

- [1] investigation of the hydrostatic pressure in fluids at rest
- [2] tiltable water tank with fill level scale
- [3] lever arm with different weights

Technical data

Water tank

- inclination angle: $0^\circ \dots 90^\circ$
- content: $0 \dots 1,8L$
- scale: $0 \dots 250mm$
- effective area, max. $75 \times 100mm$

Lever arm

- max. length 250mm

Weights

- 1x 2,5N
- 1x 2N
- 2x 1N
- 1x 0,5N

LxWxH: 400x500x450 mm

Weight: approx. 12kg

Scope of delivery

- 1 experimental unit
- 1 set of weights
- 1 set of tools
- 1 set of instructional material

HM 150.05

Hydrostatic pressure in liquids

Optional accessories

020.30009

WP 300.09

Laboratory trolley