

HM 150.09

Horizontal flow from a tank



Description

- visualisation of the trajectory of the outlet jet
- study of openings with different diameters and contours
- determination of the contraction coefficient

Hydrodynamics considers the relationship between the trajectory, the outlet contour and the outlet velocity during flow from tanks. These considerations have practical applications in hydraulic engineering or in the design of bottom outlets in dams, for example.

HM 150.09 allows a user to study and visualise the profile of a water jet. Additionally, the contraction coefficient can be determined as a characteristic for different contours.

The experimental unit includes a transparent tank, a point gauge and a panel for visualising the jet paths. An interchangeable insert is installed in the tank's water outlet to facilitate the investigation of various openings. Four inserts with different diameters and contours are provided along with the unit.

To visualise the trajectory, the issued water jet is measured via a point gauge that consists of movable rods. The rods are positioned depending on the profile of the water jet. This results in a trajectory that is transferred to the panel.

The tank contains an adjustable overflow and a scale. In this way, a precise adjustment and accurate reading of the fill level are possible. The experimental unit is positioned easily and securely on the work surface of the HM 150 base module. The water is supplied and the flow rate measured by HM 150. Alternatively, the experimental unit can be operated by the laboratory supply.

Learning objectives/experiments

- recording the trajectory of the water jet at different outlet velocities
- study of how the level in the tank affects the outlet velocity
- determination of the contraction coefficient for different contours and diameters
- comparison of the actual and theoretical outlet velocity

HM 150.09

Horizontal flow from a tank

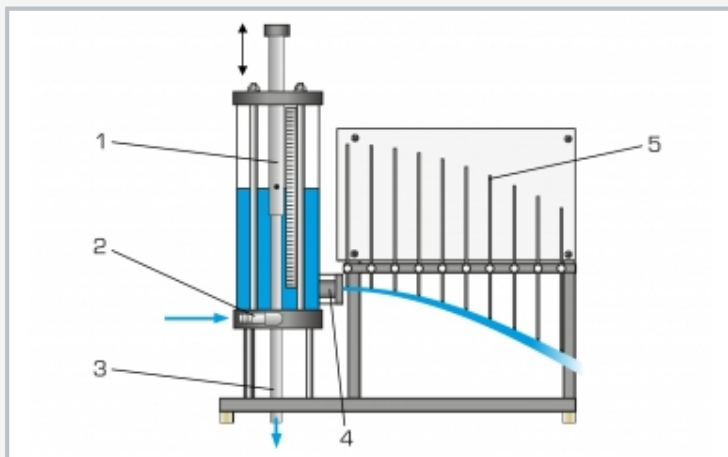

1 tank with adjustable overflow, 2 water supply, 3 water overflow, 4 water outlet, 5 point gauge for the water jet

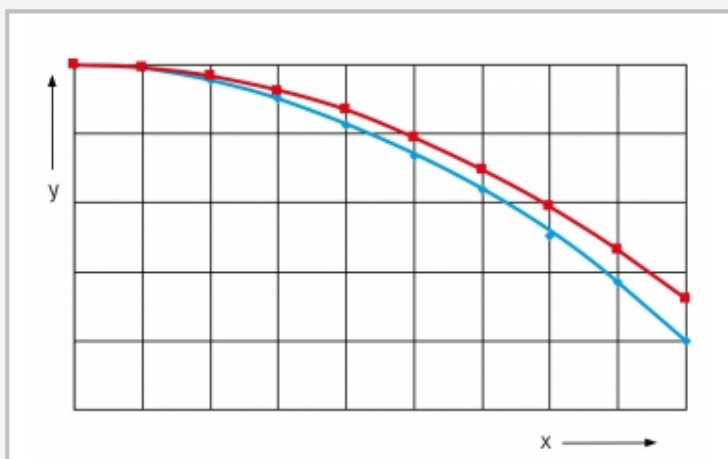

Measured and calculated (theoretical) trajectory of the outlet jet; red: theoretical, blue: measured

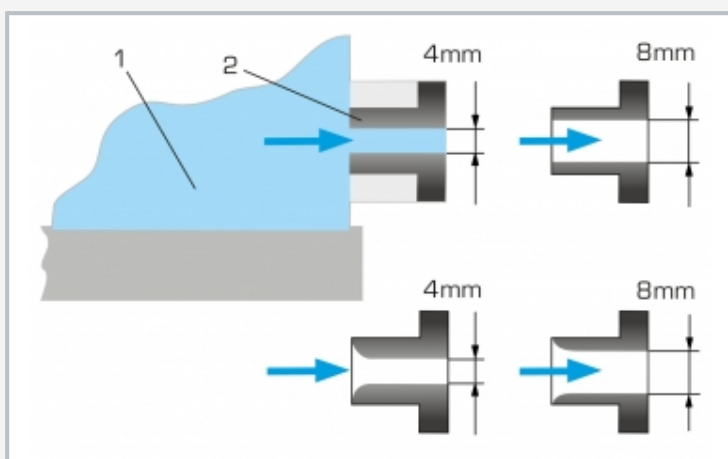

Interchangeable inserts to study different openings
1 tank, 2 insert; top: outlet from the tank through square contour, bottom: outlet from the tank through rounded contour

Specification

- [1] study of horizontal flows from tanks
- [2] determining the contraction coefficient for different outlet contours and diameters
- [3] tank with adjustable overflow and scale
- [4] four interchangeable inserts with different diameters and contours
- [5] point gauge with eight movable rods for visualisation of the jet path
- [6] white panel for recording the trajectory
- [7] flow rate determined by HM 150 base module
- [8] water supply using HM 150 base module or via laboratory supply

Technical data

Tank

- height: 510mm
- diameter: 190mm
- contents: approx. 13,5L

Inserts with rounded contour

- 1x diameter: 4mm
- 1x diameter: 8mm

Inserts with square contour

- 1x diameter: 4mm
- 1x diameter: 8mm

Point gauge, 8 movable rods

- length: 350mm

LxWxH: 865x640x590mm

Weight: approx. 27kg

Required for operation

HM 150 (closed water circuit) or water connection, drain

Scope of delivery

- 1 experimental unit
- 4 inserts
- 1 set of instructional material

HM 150.09

Horizontal flow from a tank

Optional accessories

070.15000

HM 150

Base module for experiments in fluid mechanics