

# HM 150.11

## Losses in a pipe system

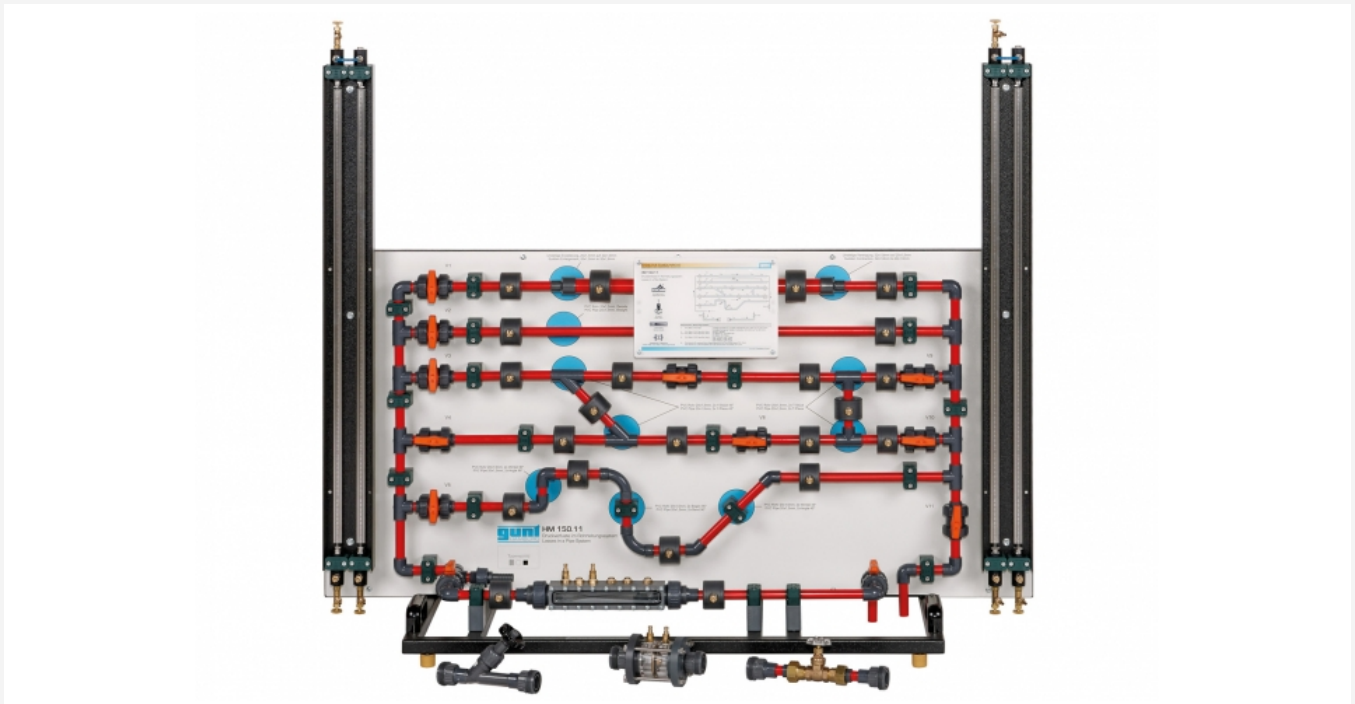

### Description

- **pressure losses in the piping system**
- **pressure measurement without interaction via annular chambers**
- **transparent measuring objects for determining flow rate**

Pressure losses occur during the flow of real fluids due to friction and turbulence (vortices). Pressure losses in pipes, piping elements, fittings and measuring instruments (e.g. flow meter, velocity meter) cause pressure losses and must therefore be taken into account when designing piping systems.

HM 150.11 allows to study the pressure losses in pipes, piping elements and shut-off devices. In addition, the differential pressure method is presented for measuring the flow rate.

The experimental unit contains six different pipe sections capable of being shut off individually. The pipe sections are equipped with piping elements such as bends, elbows and branches. In one pipe section, different shut-off devices and measuring objects are installed to determine the flow rate. The measuring objects are made of transparent material and provide excellent insight into the inner structure. The pressure measuring points in the piping system are designed as annular chambers. This creates a largely interference-free pressure measurement.

The experiments measure the pressure losses in pipes and piping elements, such as branches and bends. The opening characteristic of the shut-off devices are also recorded. The pressures are measured with tube manometers.

The experimental unit is positioned easily and securely on the work surface of the HM 150 base rate module. The water is supplied and the flow rate measured by HM 150. Alternatively, the experimental unit can be operated by the laboratory supply.

### Learning objectives/experiments

- pressure losses in pipes, piping elements and fittings
- how the flow velocity affects the pressure loss
- determining resistance coefficients
- opening characteristics of angle seat valve and gate valve
- familiarisation with various measuring objects for determining flow rate:
  - ▶ Venturi nozzle
  - ▶ orifice plate flow meter and measuring nozzle

# HM 150.11

## Losses in a pipe system

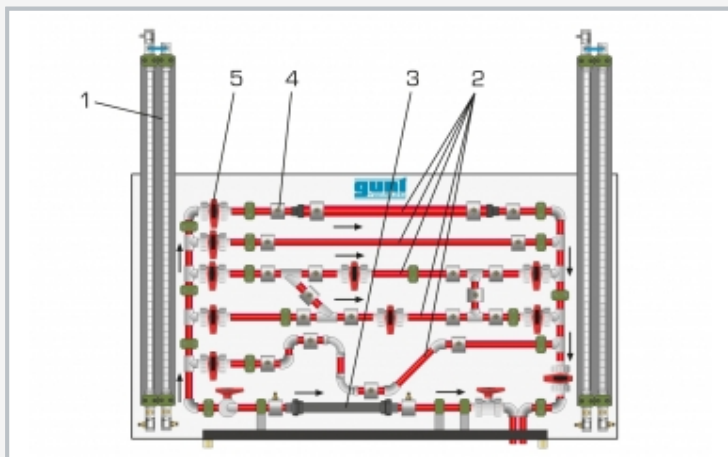

1 tube manometers, 2 various pipe sections, 3 pipe section for interchangeable shut-off/measuring objects, 4 annular chamber, 5 ball valve

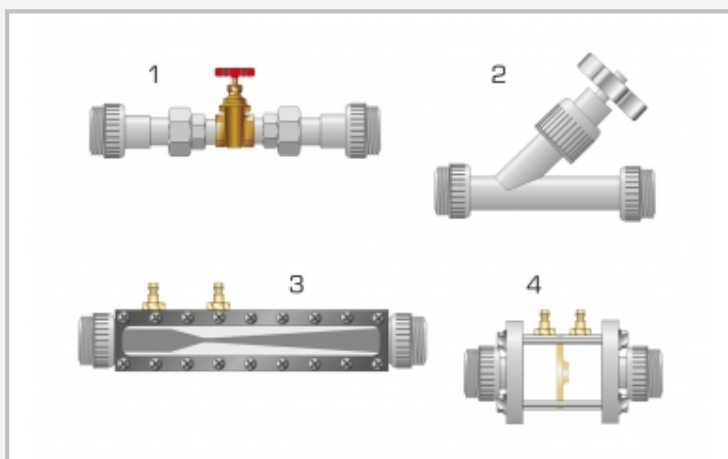

Shut-off devices and measuring objects for determining flow rate: 1 gate valve, 2 angle seat valve, 3 Venturi nozzle, 4 orifice plate flow meter or measuring nozzle

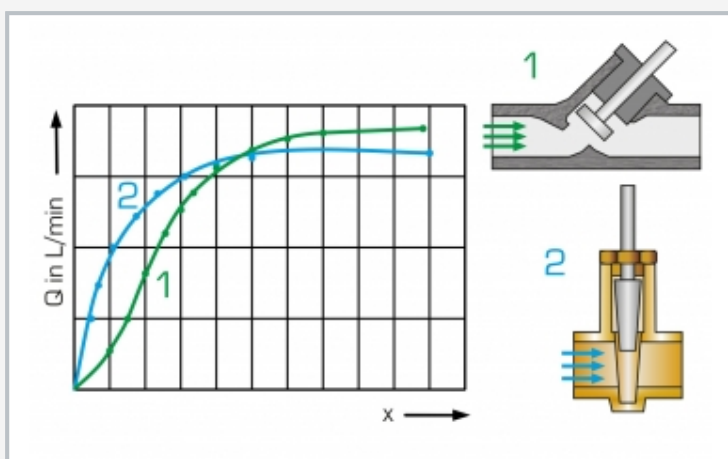

Opening characteristics of shut-off devices; Q flow rate, x opening, blue: angle seat valve, green: gate valve; 1 angle seat valve, 2 gate valve

### Specification

- [1] investigation of pressure losses in piping elements and shut-off devices
- [2] different measuring objects for determining flow rate according to the differential pressure method
- [3] six pipe sections capable of being individually shut off, with different piping elements: sudden contraction, sudden enlargement, Y-pieces, T-pieces, corners and bends
- [4] one pipe section to hold interchangeable shut-off/measuring objects
- [5] measuring objects made of transparent material: Venturi nozzle, orifice plate flow meter and measuring nozzle
- [6] shut-off devices: angle seat valve, gate valve
- [7] annular chambers allow measurement of pressure without interaction
- [8] 2 twin tube manometers for measuring the pressure difference
- [9] flow rate determined by HM 150 base module
- [10] water supply using HM 150 base module or via laboratory supply

### Technical data

Pipe section to hold fittings or measuring objects

- 20x1,5mm, PVC

Pipe sections

Inside diameter: d

- straight: d=20x1,5mm, length: 800mm, PVC
  - sudden contraction: d=32x1,8-20x1,5mm, PVC
  - sudden enlargement: d=20x1,5-32x1,8mm, PVC
  - with 2x Y-piece 45° and 2x T-piece
  - with 2x 90° elbow/bend: d=20x1,5mm, PVC and 2x 45° elbow: d=20x1,5mm, PVC
- 2x twin tube manometers: 0...1000mmWC

Measuring ranges

- pressure: 0...0,1 bar

LxWxH: 1550x640x1300mm

Weight: approx. 58kg

### Required for operation

HM 150 (closed water circuit) or water connection, drain

### Scope of delivery

- 1 experimental unit
- 2 shut-off devices (angle seat valve, gate valve)
- 1 Venturi nozzle
- 1 orifice plate flow meter or measuring nozzle
- 1 set of hoses
- 1 set of tools
- 1 set of instructional material

# HM 150.11

## Losses in a pipe system

Optional accessories

070.15000

HM 150

Base Module for Experiments in Fluid Mechanics