

HM 150.15

Hydraulic ram – pumping using water hammer



Learning objectives/experiments

- demonstrate formation and effect of water hammer
- principle of a ram
- function of an air vessel
- effect of air volume in the air vessel and the flow velocity on the pump behaviour
- efficiency analysis

Description

- **formation and effect of water hammer**
- **principle of a ram**
- **transparent tank and visible check valve for optimal observation of the function**

Abruptly interrupting the water flow can cause water hammer in the pipeline. This generally undesired effect is used specifically in special equipment (hydraulic ram) to raise water to a higher level. Unlike conventional pumps, no additional mechanical drive is required here.

HM 150.15 can be used to demonstrate the formation and effect of water hammer and to study how a hydraulic ram works. The water is fed to the ram via a long pipe at a gradient.

Above a certain water velocity the waste valve in the ram closes automatically, due to the flow forces. This happens suddenly, so that the kinetic energy of the water in the pipe is converted into potential pressure energy. The pressure opens a check valve and the water flows into an air vessel. The air cushion in the air vessel dampens the water hammer and ensures a uniform lift into the elevated tank. After the water hammer has subsided, the waste valve opens due to the dead weight, the water in the pipe starts to flow again and the process repeats itself.

The operation of the waste valve as a function of the weight load, the valve lift and the flow rate is studied. Furthermore, it is possible to show how the volume of air in the air vessel affects the lift.

Valves are used to adjust the flow rate. Transparent tank, a visible check valve in the air vessel and the visible movement of the waste valve all permit excellent observation of the function. All components are clearly mounted on a front plate.

The water is supplied and flow rate measured by the base module HM 150. Alternatively, the experimental unit can be operated by the laboratory supply.

HM 150.15

Hydraulic ram – pumping using water hammer

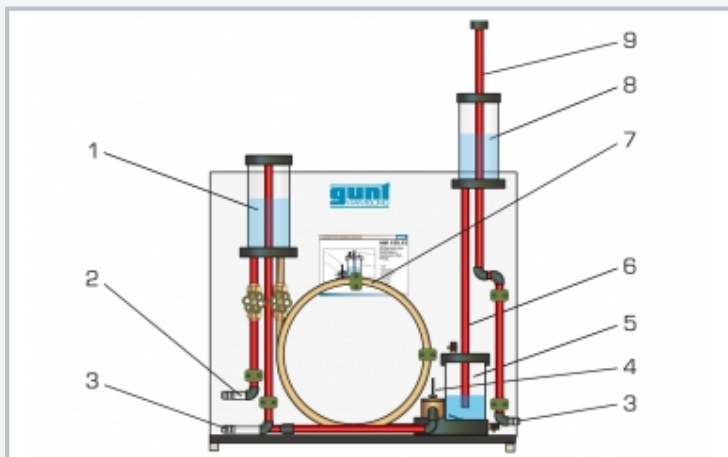

1 inlet tank with fixed overflow, 2 water connection, 3 water discharge, 4 waste valve with lift, 5 air vessel with air volume and check valve, 6 riser, 7 pipe, 8 elevated tank, 9 adjustable overflow

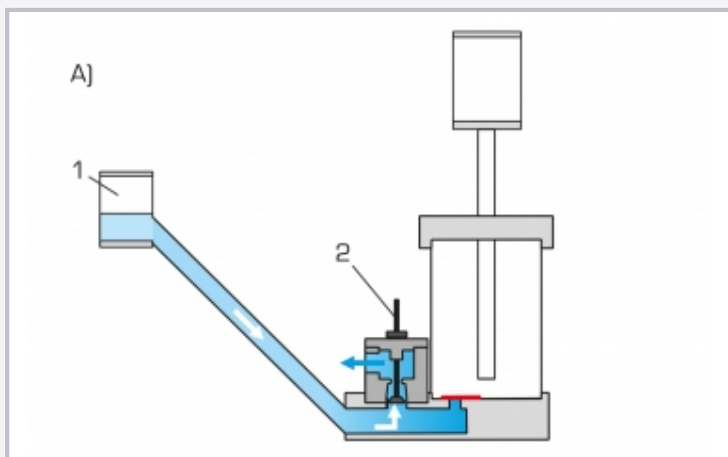

Principle of operation of a hydraulic ram: A) waste valve open, check valve closed, water outlet through waste valve; 1 inlet tank, 2 waste valve

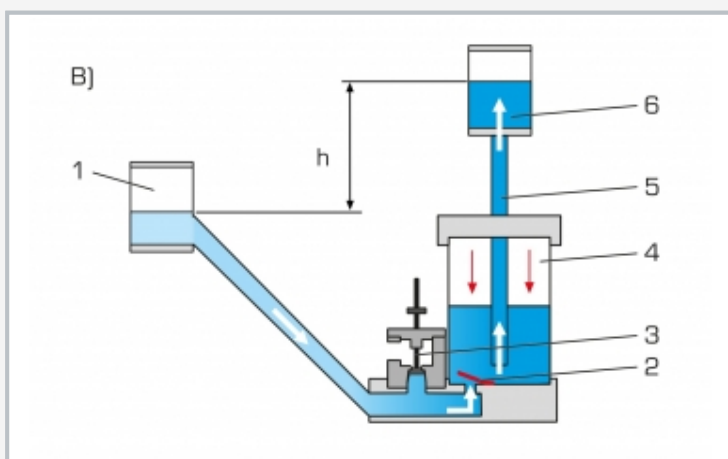

B) waste valve closed, check valve open, water inlet to air vessel and elevated tank; 1 inlet tank, 2 check valve, 3 waste valve, 4 air vessel with air volume, 5 riser, 6 elevated tank; h head

Specification

- [1] formation and effect of water hammer
- [2] pumping using water hammer
- [3] fixed overflow tank is used as a water source, e.g. river, pool
- [4] elevated tank with variable pump head
- [5] waste valve with adjustable lift, closes cyclically due to flow force of the water
- [6] tank with check valve and air volume is used as an air vessel
- [7] air volume in the air vessel is varied by vent valve
- [8] flow rate measurement using base module HM 150
- [9] closed water supply using base module HM 150 or via lab supply

Technical data

Ram

- max. head 0,27m
- max. flow rate: 90L/h

LxWxH: 1100x640x1400mm

Weight: approx. 57kg

Required for operation

HM 150 (closed water circuit) or water connection, drain

Scope of delivery

- 1 experimental unit
- 1 set of hoses
- 1 set of weights
- 1 set of instructional material

HM 150.15

Hydraulic ram – pumping using water hammer

Optional accessories

070.15000

HM 150

Base Module for Experiments in Fluid Mechanics