

## HM 283

### Experiments with a centrifugal pump



#### Description

- **determination of characteristic pump variables**
- **closed water circuit**
- **GUNT software for data acquisition, visualisation and operation**
- **part of the GUNT-Labline fluid energy machines**

Centrifugal pumps are turbomachines which are used to transport fluids. The rotation of the pump impeller generates centrifugal forces. These forces are used to deliver the water.

The experimental unit provides the basic experiments to get to know the operating behaviour and the important characteristic variables of centrifugal pumps.

HM 283 features a closed water circuit with water tank and a centrifugal pump with variable speed via frequency converter. The pump housing is transparent. This enables to observe the pump impeller in operation and the occurrence of cavitation. Valves in the inlet and outlet of the pump allow the setting of different pressure conditions.

The experimental unit is fitted with sensors for pressure, temperature and flow rate. The microprocessor-based measuring technique is well protected in the housing. All the advantages of software-supported experiments and evaluation are offered by the GUNT software and the microprocessor. The connection to a PC is made by USB.

#### Learning objectives/experiments

- principle of operation of a centrifugal pump
- recording of pump characteristics
- effect of speed on head
- effect of speed on flow rate
- determination of pump efficiency
- cavitation effects
- effect of incorrect direction of rotation

# HM 283

## Experiments with a centrifugal pump



1 water tank, 2 temperature sensor, 3 valve at inlet, 4 pressure sensor at inlet, 5 pump, 6 pressure sensor at outlet, 7 motor, 8 flow meter, 9 valve at outlet

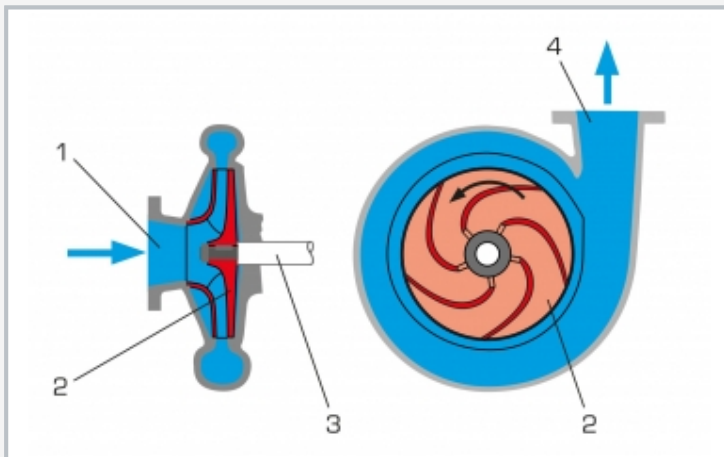

Principle of operation of a centrifugal pump  
1 water inlet, 2 pump impeller, 3 pump shaft, 4 water outlet

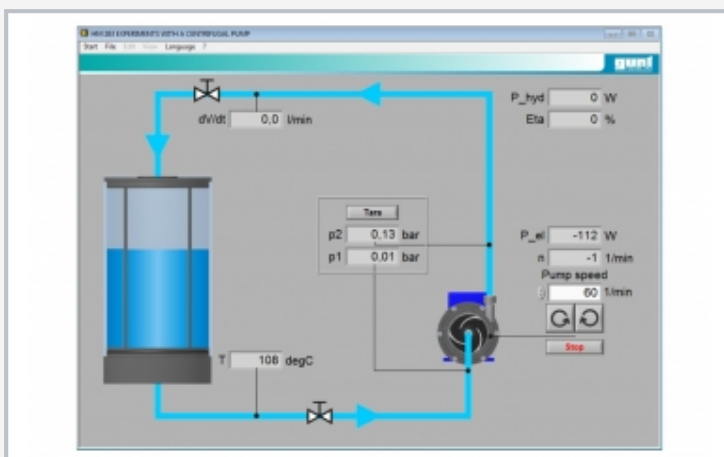

Operating interface of the powerful software

### Specification

- [1] functioning and operating behaviour of a centrifugal pump
- [2] closed water circuit contains centrifugal pump with drive motor and a transparent water tank
- [3] transparent housing for observing the pump impeller
- [4] variable speed via frequency converter
- [5] adjustment of pressure conditions at inlet and outlet side of the pump by valves
- [6] sensors for pressure at inlet and outlet side of the pump, temperature and flow rate
- [7] microprocessor-based measuring technique
- [8] GUNT software with control functions and data acquisition via USB under Windows 7, 8.1, 10

### Technical data

- Centrifugal pump with drive motor
- power consumption: 370W
  - speed: 0...3000min<sup>-1</sup>
  - max. flow rate: approx. 40L/min
  - max. head: approx. 10m

Water tank: approx. 15L

#### Measuring ranges

- pressure (inlet): ± 1 bar
- pressure (outlet): 0...5bar
- flow rate: 3,5...50L/min
- temperature: 0...130°C

230V, 50Hz, 1 phase  
230V, 60Hz, 1 phase; 120V, 60Hz, 1 phase  
UL/CSA optional  
LxWxH: 660x590x720mm  
Weight: approx. 46kg

### Required for operation

PC with Windows

### Scope of delivery

- 1 experimental unit
- 1 GUNT software CD + USB cable
- 1 set of instructional material

# HM 283

## Experiments with a centrifugal pump

Optional accessories

020.30009

WP 300.09

Laboratory trolley