

HM 285

Experiments with a piston pump



Description

- illustrative model of a typical positive displacement pump
- closed water circuit
- GUNT software for data acquisition, visualisation and operation
- part of the GUNT-Labline fluid energy machines

Piston pumps belong to the group of positive displacement pumps. They transport the medium by a reciprocating motion of a piston in the pump working space, called stroke. The stroke creates a suction hence vacuum effect used to deliver the water. Piston pumps are used when high pressures are to be generated. The flow rate of piston pumps is independent of the head and is determined only by speed. Its good suction performance is outstanding.

The experimental unit provides the basic experiments to get to know the operating behaviour and the important characteristic variables of piston pumps.

HM 285 features a closed water circuit with water tank, a piston pump with variable speed via a frequency converter and an air vessel. The piston of the pump is mounted in a transparent housing and can be observed during operation. The cycle that takes place (intake and discharge of water) can be shown clearly in the p-V diagram. The pulsating pressure curve of the pump can be damped with the aid of the air vessel. Flow rate and head are adjusted via a needle valve and overflow valve.

The experimental unit is fitted with sensors for pressure and flow rate. One pressure sensor measures the pressure at the outlet of the pump, another one measures the pressure in the inside of the cylinder. The position of the piston rod is measured by an angle sensor. This allows the determination of the cylinder volume. The microprocessor-based measuring technique is well protected in the housing. All the advantages of software-supported experiments and evaluation are offered by the GUNT software and the microprocessor. The connection to a PC is made by USB.

Learning objectives/experiments

- principle of operation of a piston pump
- recording of pump characteristics
- pressure curves of delivery pressure and cylinder pressure
- influence of pulsation damping
- p-V diagram
- determination of efficiencies

HM 285

Experiments with a piston pump



1 overflow valve, 2 pressure sensor at outlet, 3 water tank, 4 air vessel, 5 piston pump, 6 motor, 7 flow meter, 8 needle valve for adjusting the flow rate

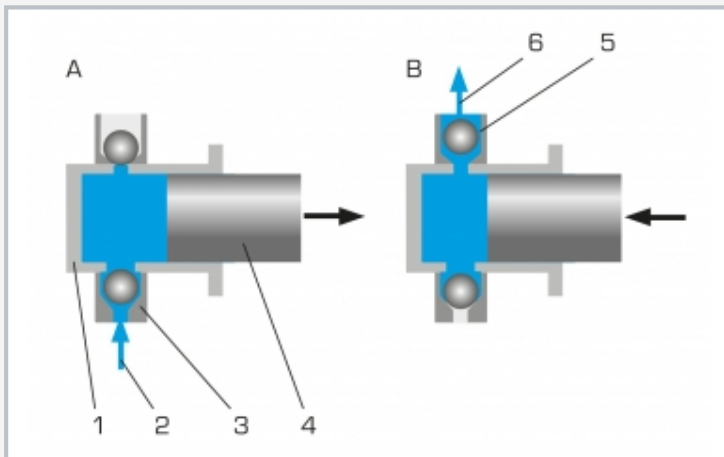

Principle of operation of a piston pump: A intake, B discharge
1 cylinder, 2 water inlet, 3 valve at inlet, 4 plunger piston, 5 valve at outlet, 6 water outlet

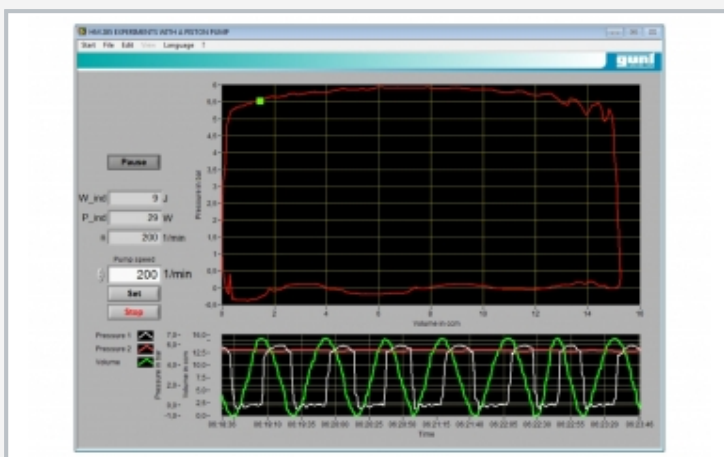

Operating interface of the powerful software

Specification

- [1] functioning and operating behaviour of a piston pump
- [2] closed water circuit contains piston pump with variable speed via frequency converter, transparent water tank and air vessel
- [3] transparent housing for observing the pump piston
- [4] needle valve for adjusting the flow rate
- [5] overflow valve for adjusting the head
- [6] pulsation damping of the head using air vessel with bleed valve
- [7] sensors for pressure at outlet and in the cylinder of the pump, flow rate and crank angle
- [8] microprocessor-based measuring technique
- [9] GUNT software with control functions and data acquisition via USB under Windows 7, 8.1, 10

Technical data

- Piston pump
- speed: 30...180min⁻¹
 - max. flow rate: 135L/h
 - max. head: 40m
- Drive motor
- power: 180W
- Gear transmission ratio: $i=7,5$
 Overflow valve: 1...4bar
- Measuring ranges
- pressure (cylinder): 0...5bar
 - pressure (outlet): 0...5bar
 - crank angle: 0...360°
 - flow rate: 0,2...6L/min

- 230V, 50Hz, 1 phase
- 230V, 60Hz, 1 phase; 120V, 60Hz, 1 phase
- UL/CSA optional
- LxWxH: 670x590x740mm
- Weight: approx. 49kg

Required for operation

PC with Windows

Scope of delivery

- 1 experimental unit
- 1 GUNT software CD + USB cable
- 1 set of instructional material

HM 285

Experiments with a piston pump

Optional accessories

020.30009

WP 300.09

Laboratory trolley