

HM 365.20

Oil pump supply unit



Description

- closed oil circuit for supplying the oil pumps
- GUNT software for data recording and visualisation
- part of the GUNT-FEMLine

Oil pumps are driven machines. Depending on the viscosity of the oil they work either according to the positive displacement principle for high viscosity oils, or as rotodynamic pumps for low viscosity oils. Oil pumps are used to deliver oil required in machines or plants for the purpose of lubrication or cooling. Another area of application is the use of oil to transfer energy in the field of hydraulics.

The supply unit HM 365.20 provides the working medium oil for several oil pumps (HM 365.21 to HM 365.24). The pumps are powered by the drive unit HM 365.

The trainer includes a closed oil circuit with an internal oil tank. The individual pumps are placed on the work surface and connected via hoses. To power the pump, it is connected to the drive unit HM 365 with a V-belt. The supply unit is equipped with a closed-circuit air/oil cooling system that cools the oil.

The flow rate is measured with an oval wheel flow meter. A temperature sensor records the temperature in the piping system. The trainer has pressure sensors to measure the inlet and outlet pressures. The measured values are read from digital displays on the supply unit and can be transmitted simultaneously via USB directly to a PC, where they can be analysed using the included software.

Learning objectives/experiments

- in combination with HM 365 and a pump of the series HM 365.21 – HM 365.24
 - ▶ recording of pump characteristics
 - ▶ determination of the power requirement of the pump
 - ▶ determination of the hydraulic power of the pump
 - ▶ determination of the pump efficiency
 - ▶ determination of the system characteristics and the operating point of the pump

HM 365.20

Oil pump supply unit

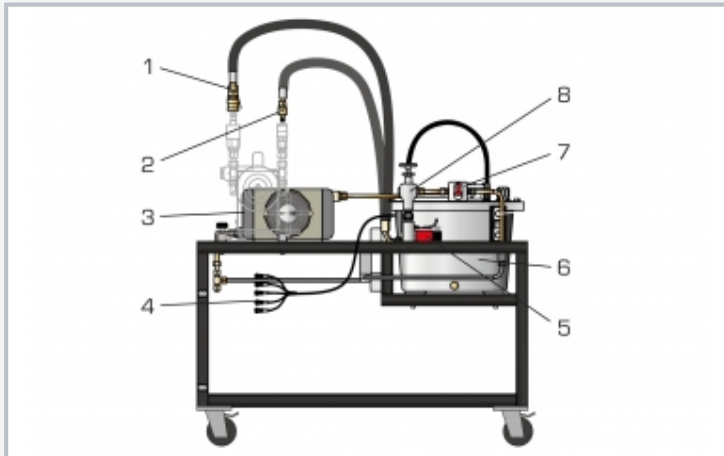

1 inlet, 2 outlet, 3 closed-circuit cooling system (air/oil), 4 connections for display unit, 5 pressure sensor, 6 oil tank, 7 oval wheel flow meter, 8 adjustable pressure valve

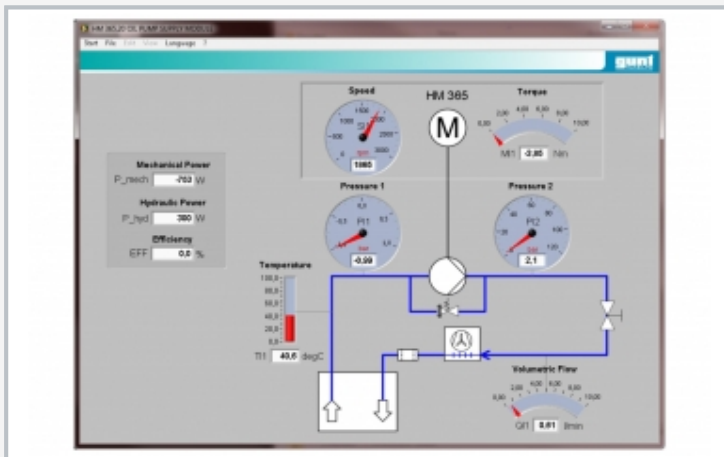

GUNT software screenshot: process schematic



Functional experimental setup: drive unit HM 365 (left), HM 365.20 with pump under investigation (right)

Specification

- [1] supply unit for operation of different oil pumps HM 365.21 to HM 365.24
- [2] closed oil circuit
- [3] connection of pumps via hydraulic hoses with quick-release couplings
- [4] pressure sensors at the inlet and outlet included in the scope of delivery of the pumps
- [5] measurement of the oil temperature in the pipeline system with PT100
- [6] closed-circuit cooling via air/oil heat exchanger
- [7] flow measurement with oval wheel flow meter
- [8] digital display of flow, pressure and temperature
- [9] GUNT software for data acquisition via USB under Windows 7, 8.1, 10

Technical data

Oil container: 27L
 Oil: HLP-ISO 32
 Oil cooling 2...3kW

Measuring ranges
 pressure (inlet): ± 1 bar
 pressure (outlet): 0...120bar
 temperature: 0...1000°C
 flow rate: 0...10L/min

230V, 50Hz, 1 phase
 230V, 60Hz, 1 phase
 120V, 60Hz, 1 phase
 LxWxH: 1200x850x1300mm
 Weight: approx. 80kg

Required for operation

PC with Windows recommended

Scope of delivery

- 1 supply unit
- 1 display unit
- 1 CD with GUNT software + USB cable
- 2 hoses with quick-release couplings
- 1 set of instructional material

HM 365.20

Oil pump supply unit

Required accessories

070.36500	HM 365	Universal drive and brake unit
-----------	--------	--------------------------------

Optional accessories

070.36521	HM 365.21	Screw pump
070.36522	HM 365.22	External gear pump
070.36523	HM 365.23	Vane pump
070.36524	HM 365.24	Internal gear pump