

HM 365.45

Axial-flow pump



Learning objectives/experiments

- in combination with HM 365
 - ▶ determination of the pressure/volume characteristics
 - ▶ determination of the power requirement of the pump
 - ▶ determination of the hydraulic power
 - ▶ determination of the efficiency
 - ▶ determination of the head
 - ▶ determination of the system characteristics

Description

- **Operating behaviour of an axial-flow pump**
- **GUNT software for data recording and visualisation**
- **Part of the GUNT-FEMLine**

In an axial-flow pump the pumping medium flows through the impeller (here a propeller) in the axial direction. In axial-flow pumps, the pressure build-up is not achieved by the centrifugal force but, like the aerodynamic principle, by the propeller blade. Therefore these pumps are also known as propeller pumps. They are not self-priming and the propeller must always be covered by the pumping medium. Axial propeller pumps are used when high flow rates and a small head are needed. The typical areas of application for propeller pumps are drainage systems, wastewater treatment plants and cooling water supply systems.

The HM 365.45 trainer includes an axial propeller pump, a tank and pipelines with generously designed pipe cross-sections. The pump is powered in conjunction with the HM 365 Universal Drive and Brake Unit. The closed water circuit means that the trainer can be used independently of the water system.

The trainer is equipped with measuring elements for the pressures at the inlet and outlet of the pump. A temperature sensor measures the water temperature. The flow rate is measured with an electromagnetic flow meter. The measured values are read from digital displays and can be transmitted simultaneously via USB directly to a PC, where they can be analysed using the software included.

HM 365.45

Axial-flow pump

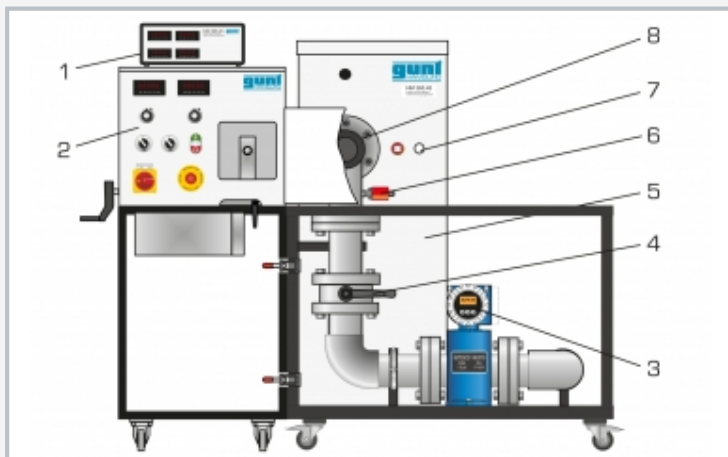

1 measuring amplifier, 2 drive unit HM 365, 3 flow meter, 4 valve, 5 water tank, 6 pressure sensor, 7 temperature sensor, 8 V-belt pulley of the axial-flow pump

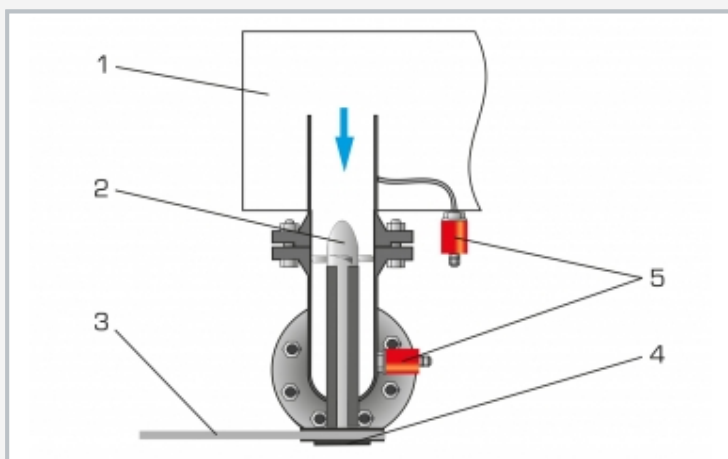

1 tank, 2 pump impeller, 3 drive belt, 4 V-belt pulley, 5 pressure sensors

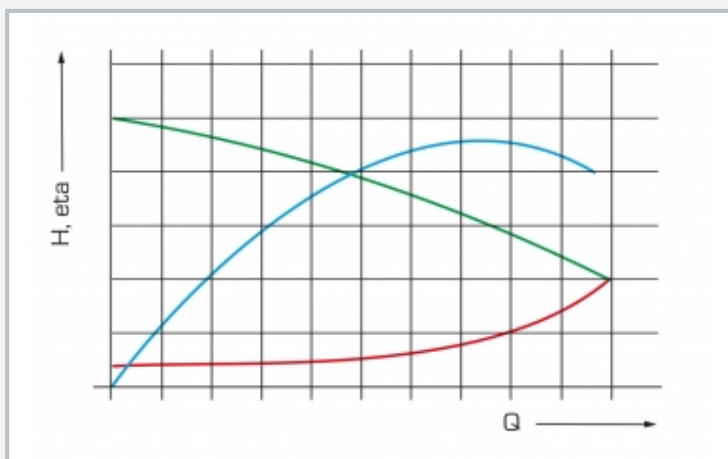

Pump characteristics: Q flow rate; red: system characteristics, green: pump head H, blue: pump efficiency eta

Specification

- [1] investigation of an axial-flow pump
- [2] closed water circuit
- [3] powered by HM 365 Universal Drive and Brake Unit
- [4] water tank with sight glass
- [5] determination of the flow rate with the electromagnetic flow rate sensor
- [6] digital display of flow rate, pressure and temperature
- [7] GUNT software for data acquisition via USB under Windows 7, 8.1, 10

Technical data

Pump

- output: 1000W at 1000min⁻¹
- max. flow rate: 700L/min
- max. head: 1,75m

Tank: 160L

Measuring ranges

- flow rate: 0...1200L/min
- temperature: 0...100°C
- pressure (inlet): ±1 bar
- pressure (outlet): 0...0,6bar

230V, 50Hz, 1 phase
 230V, 60Hz, 1 phase
 120V, 60Hz, 1 phase
 UL/CSA optional
 LxWxH: 1110x800x1380mm
 Weight: approx. 170kg

Scope of delivery

- 1 trainer
- 1 measuring amplifier
- 1 GUNT software CD + USB cable
- 1 set of instructional material

HM 365.45

Axial-flow pump

Required accessories

070.36500 HM 365 Universal drive and brake unit