

HM 450.01

Pelton turbine

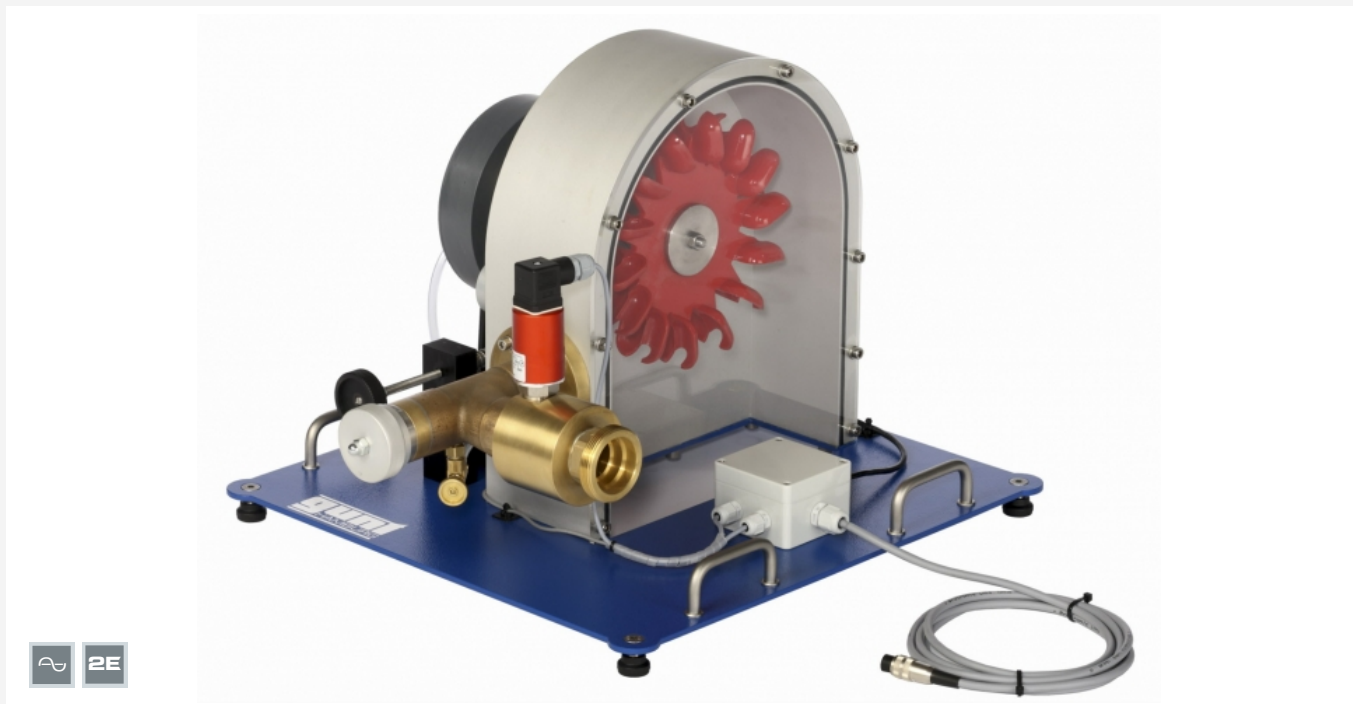

Description

- Pelton turbine with visible operating area
- closed water circuit and data processing software for use with the HM 450C trainer

The Pelton turbine is a type of free-jet resp. impulse turbine which convert the pressure energy of water into kinetic energy entirely in the distributor. Pelton turbines are used at large heads and relatively low flow rates. The turbine power is adjusted by means of the nozzle cross-section. In practice, Pelton turbines are used for driving synchronous generators, where they run at constant speed.

The Pelton turbine HM 450.01 is an accessory for the HM 450C trainer. The experimental unit consists of the Pelton wheel, a needle nozzle used as distributor, a band brake for loading the turbine and a housing with a transparent front panel. The transparent cover enables you to observe the water flow, the Pelton wheel and the nozzle during operation. You can change the nozzle cross-section and thus the flow rate by adjusting the nozzle needle.

The pressure at the turbine inlet is recorded with a pressure sensor. A force sensor and a speed sensor are attached to the band brake. Thus, the mechanical power output of the turbine can be determined. Speed, torque and pressure are displayed on the switch cabinet of HM 450C and processed further in the software. Water supply and flow rate measurement are provided by HM 450C.

Learning objectives/experiments

- determination of mechanical output
- determination of efficiency
- recording of characteristic curves
- investigation of the influence of the nozzle cross-section on the power output

HM 450.01

Pelton turbine

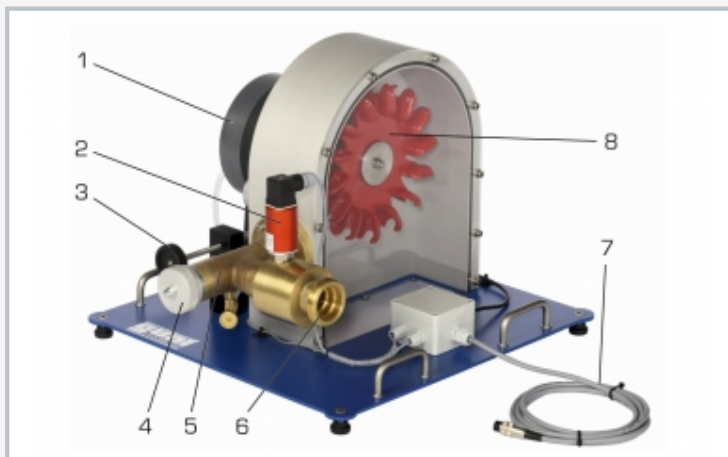

1 band brake, 2 pressure sensor, 3 handwheel for adjusting the brake, 4 handwheel for adjusting the nozzle cross-section, 5 needle nozzle, 6 water inlet, 7 connecting cable to HM 450C, 8 Pelton wheel

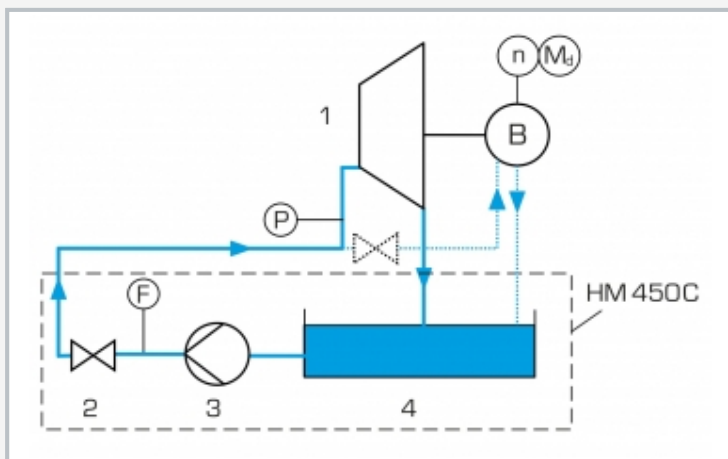

1 Pelton turbine, 2 flow control valve, 3 pump, 4 tank; blue dashed lines: cooling water; B brake; F flow rate, P pressure, n speed, M_d torque

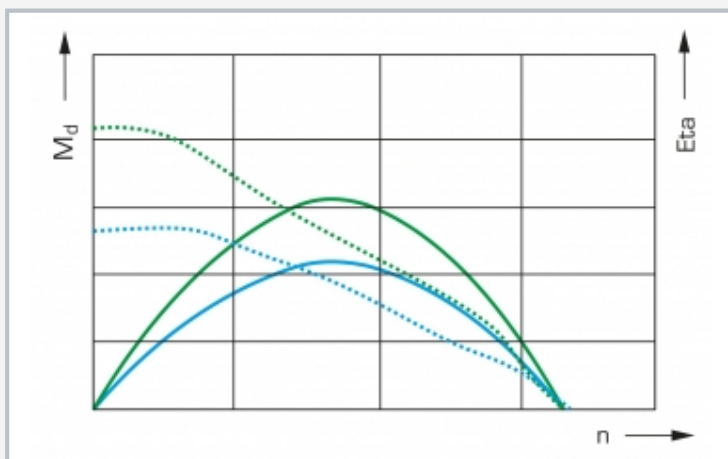

Efficiency and torque (dashed lines) depending on the speed at different powers and fully opened nozzle: green: 100% power, blue: 65% power, Eta: efficiency, n speed, M_d torque

Specification

- [1] recording the curves of a Pelton turbine and investigating the influence of the nozzle cross-section
- [2] transparent front panel for observing the operating area
- [3] loading the turbine by use of a band brake
- [4] adjustable nozzle needle for setting different nozzle cross-sections
- [5] non-contact speed measurement at the turbine shaft and force sensor at the brake for measuring the torque
- [6] force sensor at the turbine inlet
- [7] speed, torque and pressure displayed on the switch cabinet of HM 450C
- [8] water supply, flow rate measurement and data processing software via HM 450C

Technical data

Turbine

- output: approx. 350W at 1000min^{-1} , 150L/min, $H=20\text{m}$
- max. speed: 1500min^{-1}
- Pelton wheel
 - ▶ 14 blades
 - ▶ medium diameter: 165mm

Measuring ranges

- torque: 0...9,81Nm
- pressure: 0...4bar abs.
- speed: 0...4000 min^{-1}

LxWxH: 600x490x410mm

Weight: approx. 27kg

Scope of delivery

- 1 experimental unit
- 1 set of instructional material

HM 450.01

Pelton turbine

Required accessories

070.450C0 HM 450C Characteristic variables of hydraulic turbomachines