

# HM 450C

## Characteristic variables of hydraulic turbomachines



The illustration shows HM 450C together with the two turbines HM 450.01 (left) and HM 450.02 (right).

### Description

- **characteristic variables of water turbines and centrifugal pumps**
- **pelton turbine HM 450.01 and Francis turbine HM 450.02 extend the scope of experiments**
- **pumped storage plant**

Turbomachines such as pumps and turbines are energy converters. Turbines convert flow energy into mechanical energy and pumps convert mechanical energy into flow energy.

HM 450C can be used to investigate a centrifugal pump. Experiments can be performed on two key water turbine designs: Pelton and Francis turbine, available as accessories HM 450.01 and HM 450.02.

The closed water circuit comprises a tank, a standard centrifugal pump with variable speed and a flow control valve to adjust the back pressure.

The speed is detected contact-free by means of an inductive displacement sensor on the motor shaft. To determine the drive power, the drive motor is mounted on swivel bearings and equipped with a force sensor to measure the drive torque. Pressures at the inlet and outlet of the pump are measured. The flow rate is measured by

means of an electromagnetic flow meter. The measured values are displayed digitally and processed further on a PC. The PC is used to calculate the power output data of the examined turbomachine and to represent them in characteristics.

One of the turbines HM 450.01 or HM 450.02 can also be placed on top of the storage tank. The centrifugal pump supplies the turbine with water. The measured values of the turbine are transferred via cable to HM 450C. A special feature of HM 450C is the ability to operate pump and turbine at the same time. Relevant measured values are recorded contemporaneously at both turbomachines. Thus the trainer can be used as a pumped storage plant.

### Learning objectives/experiments

- centrifugal pump
  - ▶ measuring inlet and outlet pressures of the pump
  - ▶ determining delivery height
  - ▶ determining hydraulic output
  - ▶ determining mechanical output
  - ▶ recording characteristics at various speeds
  - ▶ determining the efficiency
- with accessories Pelton turbine HM 450.01 or Francis turbine HM 450.02
  - ▶ measuring torque and speed
  - ▶ determining efficiency of the turbine
  - ▶ recording characteristics
  - ▶ demonstration of a pumped storage plant

# HM 450C

## Characteristic variables of hydraulic turbomachines



1 electromagnetic flow meter, 2 flow control valve, 3 storage tank, 4 pressure sensor at pump inlet, 5 centrifugal pump, 6 drive motor including measurement of torque, 7 pressure sensor at pump outlet, 8 switch cabinet with displays and controls

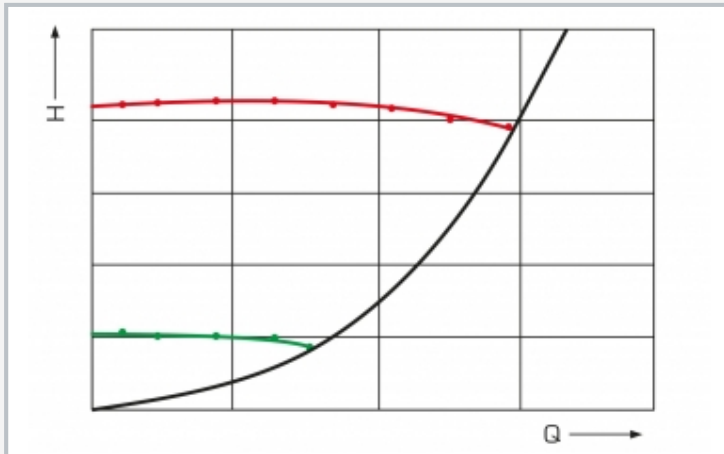

Pump characteristics: H head, Q flow rate; red: characteristics at  $n=2900\text{min}^{-1}$ , green: characteristics at  $n=1450\text{min}^{-1}$ , black: system characteristic

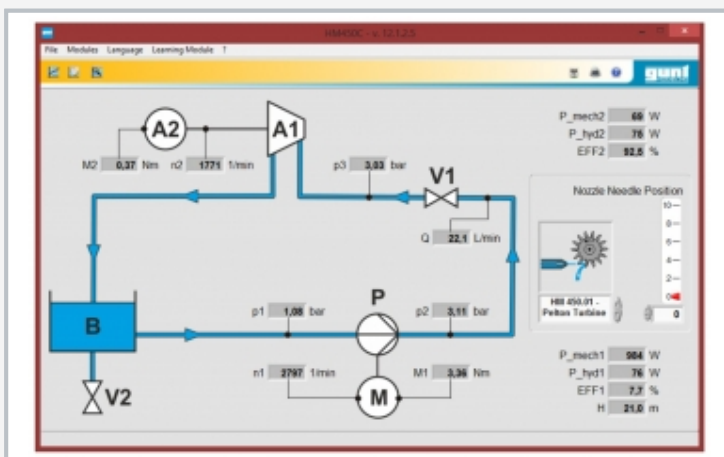

Software screenshot: Francis turbine process schematic

### Specification

- [1] determining characteristic variables of a centrifugal pump
- [2] determining characteristic variables of water turbines together with the accessories HM 450.01 and HM 450.02
- [3] experiments on a pump in a closed water circuit with storage tank and flow control valve to adjust the back pressure
- [4] experiments on turbines: closed water circuit for supplying turbines
- [5] pipes and fittings made of PVC
- [6] 3-phase AC motor for pump with variable speed via frequency converter
- [7] non-contact speed measurement at the turbine shaft and force sensor at the brake for measuring the torque
- [8] digital displays for pressures, flow rate, speed and torque
- [9] GUNT software for data acquisition via USB under Windows 7, 8.1, 10

### Technical data

Standard centrifugal pump

- max. head: 23,9m
- max. flow rate:  $31\text{m}^3/\text{h}$

Drive motor with variable speed

- power output: 2,2kW
- speed range: 0...3000 $\text{min}^{-1}$

Storage tank: 250L

Measuring ranges

- pressure: 2x 0...4bar abs.
- flow rate: 0...40 $\text{m}^3/\text{h}$
- torque: 0...20Nm
- speed: 2x 0...4000 $\text{min}^{-1}$

230V, 50Hz, 1 phase

230V, 60Hz, 1 phase

230V, 60Hz, 3 phases

UL/CSA optional

LxWxH: 1900x790x1900mm

Weight: approx. 243kg

### Required for operation

PC with Windows recommended

### Scope of delivery

- 1 trainer
- 1 GUNT software CD + USB cable
- 1 set of instructional material

# HM 450C

## Characteristic variables of hydraulic turbomachines

Optional accessories

070.45001	HM 450.01	Pelton Turbine
070.45002	HM 450.02	Francis Turbine