

## Hall effect in metals (Item No.: P2530300)

### Curricular Relevance



#### Difficulty



Difficult

#### Preparation Time



1 Hour

#### Execution Time



2 Hours

#### Recommended Group Size



2 Students

#### Additional Requirements:

#### Experiment Variations:

#### Keywords:

Normal Hall effect, anomalous Hall effect, charge carriers, Hall mobility, electrons, defect electrons

## Overview

### Short description

#### Principle

The Hall effect in thin zinc and copper foils is studied and the Hall coefficient determined. The effect of temperature on the Hall voltage is investigated.

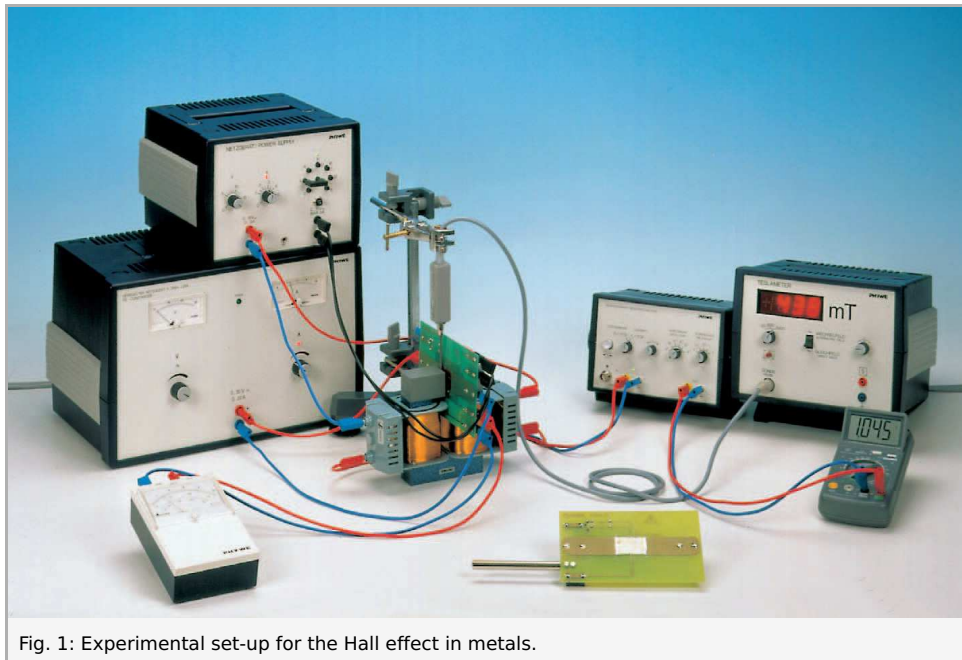

## Equipment

Position No.	Material	Order No.	Quantity
1	Hall effect, Cu, carrier board	11803.00	1
2	Hall effect, zinc, carrier board	11804.01	1
3	Coil, 300 turns	06513.01	2
4	Iron core, U-shaped, laminated	06501.00	1
5	Pole pieces, plane, 303048 mm, 2	06489.00	1
6	Power supply 0-30 VDC/20 A, stabil	13536.93	1
7	Power supply, universal	13500.93	1
8	Universal measuring amplifier	13626.93	1
9	Teslameter, digital	13610.93	1
10	Hall probe, tangent., prot. cap	13610.02	1
11	Digital multimeter	07134.00	1
12	Meter, 10/30 mV, 200 °C	07019.00	1
13	Universal clamp with join	37716.00	1
14	Tripod base -PASS-	02002.55	1
15	Support rod -PASS-, square, l = 250 mm	02025.55	1
16	Right angle clamp -PASS-	02040.55	2
17	Connecting cord, l = 750 mm, red	07362.01	6
18	Connecting cord, l = 750 mm, blue	07362.04	5
19	Connecting cord, l = 750 mm, black	07362.05	2

## Task

1. The Hall voltage is measured in thin copper and zinc foils.
2. The Hall coefficient is determined from measurements of the current and the magnetic induction.
3. The temperature dependence of the Hall voltage is investigated on the copper sample.

## Set-up and Procedure

The layout follows Fig. 1 and the wiring diagram in Fig. 2.

- Arrange the field of measurement on the plate midway between the pole pieces.
- Carefully place Hall probe in the centre of the magnetic field.
- The measuring amplifier takes about 15 min. to settle down free from drift and should therefore be switched on correspondingly earlier.
- To keep interfering fields at a minimal level, make the connecting cords to the amplifier input as short as possible.
- Take the transverse current  $I$  for the Hall probe from the powersupply unit 13536.93. It can be up to 15 A for short periods.

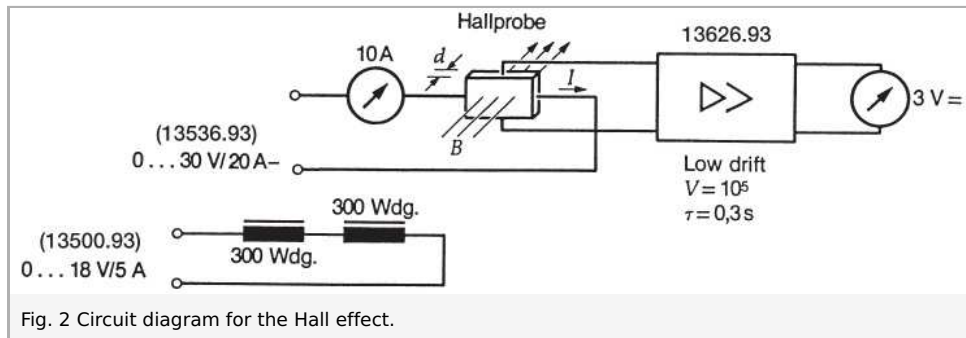

Fig. 2 Circuit diagram for the Hall effect.

The Hall probe will show a voltage at the Hall contacts even in the absence of a magnetic field, because these contacts are never exactly one above the other but only within manufacturing tolerances. Before measurements are made, this voltage must be compensated with the aid of the potentiometer as follows:

- Disconnect the transverse current  $I$ .
- Set the measuring amplifier to an output voltage of 1 V, for example, by adjusting the compensation-voltage. ( $R_e = 104 \Omega$ , amplification = 105).
- Connect the transverse current.
- Twist the connecting cords between hall voltage sockets and amplifier input in order to avoid as much as possible stray voltages..
- Adjust the compensating potentiometer, using a screwdriver, until the instrument again shows an output voltage of 1 V.
- Repeat this operation several times to obtain a precise adjustment.

The determination of the Hall voltage is not quite simple since voltages in the microvolt range are concerned where the Hall voltages are superposed by parasitic voltages such as thermal voltages, induction voltages due to stray fields, etc. The following procedure is recommended:

- Set the transverse current  $I$  to the desired value.
- Set the field strength  $B$  to the desired value (on the power supply, universal, 13500.93).
- Set the output voltage of the measuring amplifier to about 1.5 V by adjusting the compensation-voltage.
- Using the mains switch on the power supply unit, switch the magnetic field on and off and read the Hall voltages at each on and off position of the switch (after the measuring amplifier and the multi-range meter have recovered from their peak values). The difference between the two values of the voltage, divided by the gain factor 105, is the Hall voltage  $U_H$  to be determined.

## Theory and evaluation

If a current  $I$  flows through a strip conductor of thickness  $d$  and if the conductor is placed at right angles to a magnetic field  $B$ , the Lorentz force

$$\vec{F} = Q(\vec{v} \times \vec{B})$$

acts on the charge carriers in the conductor,  $n$  being the drift velocity of the charge carriers and  $Q$  the value of their charge. This leads to the charge carriers concentrating in the upper or lower regions of the conductor, according to their polarity, so that a voltage - the so-called Hall voltage  $U_H$  - is eventually set up between two points located one above the other in the strip:

$$U_H = \frac{R_H \cdot B \cdot I}{d}$$

$R_H$  is the Hall coefficient.

The type of charge carrier can be deduced from the sign of the Hall coefficient: a negative sign implies carriers with a negative charge ("normal Hall effect"), and a positive sign, carriers with a positive charge ("anomalous Hall effect"). In metals, both negative carriers, in the form of electrons, and positive carriers, in the form of defect electrons, can exist. The deciding factor for the occurrence of a Hall voltage is the difference in mobility of the charge carriers: a Hall voltage can arise only if the positive and negative charge carriers have different mobilities.

The measurements for copper shown in Fig. 3 are related by the expression  $U_H \sim B$ . Linear regression using the relation  $U_H = a + bB$  shows these values to be represented by a straight line with the slope  $b = -0.0384 \cdot 10^{-6} \text{ m}^2/\text{s}$  and a standard deviation  $s_b = 0.0004 \cdot 10^{-6} \text{ m}^2/\text{s}$ . From this, with  $d = 18 \cdot 10^{-6} \text{ m}$  and  $I = 10 \text{ A}$ , we derive the Hall coefficient

$$R_H = -(0.576 \pm 0.006) \cdot 10^{-10} \text{ m}^3/\text{As}.$$

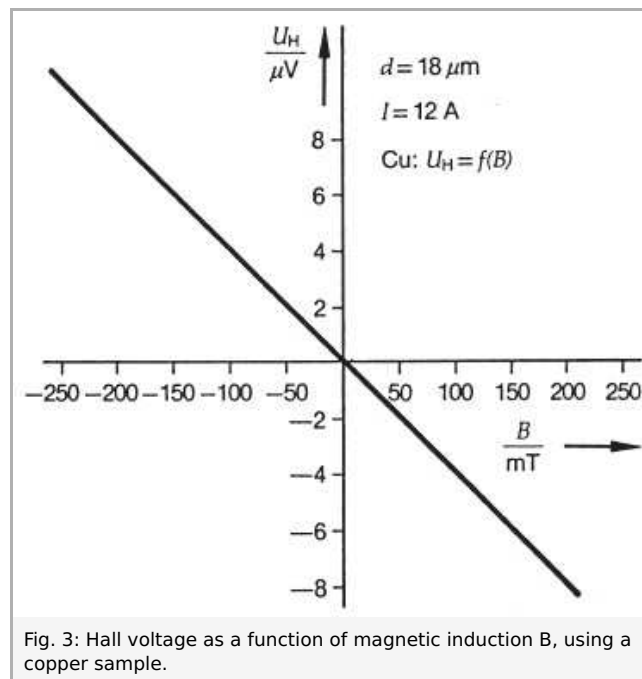

Fig. 3: Hall voltage as a function of magnetic induction  $B$ , using a copper sample.

The measurements shown in Fig. 4 confirm for copper the relation  $U_H \sim I$ . Linear regression with the relation  $U_H = a + bI$  yields a straight line with slope  $b = -0.770 \cdot 10^{-6} \text{ V/A}$  and standard deviation  $s_b = 0.005 \cdot 10^{-6} \text{ V/A}$ . From this, with  $d = 18 \cdot 10^{-6} \text{ m}$  and  $B = 0.25 \text{ T}$ , we derive the Hall coefficient

$$R_H = -(4.31 \pm 0.004) \cdot 10^{-10} \text{ m}^3/\text{As}.$$

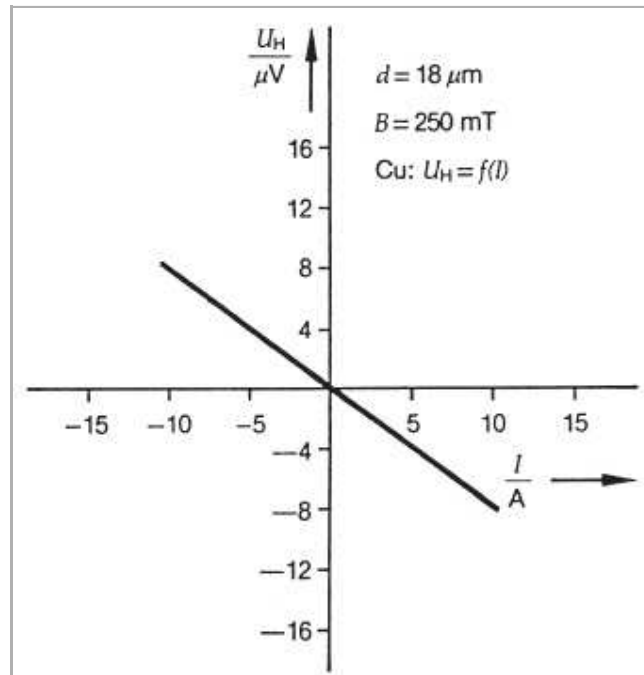

Fig. 4: Hall voltage as a function of current  $I$ , using a copper sample.

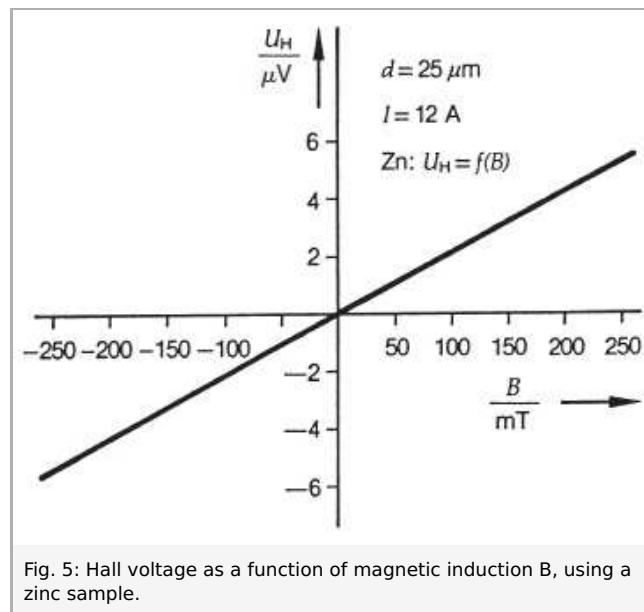
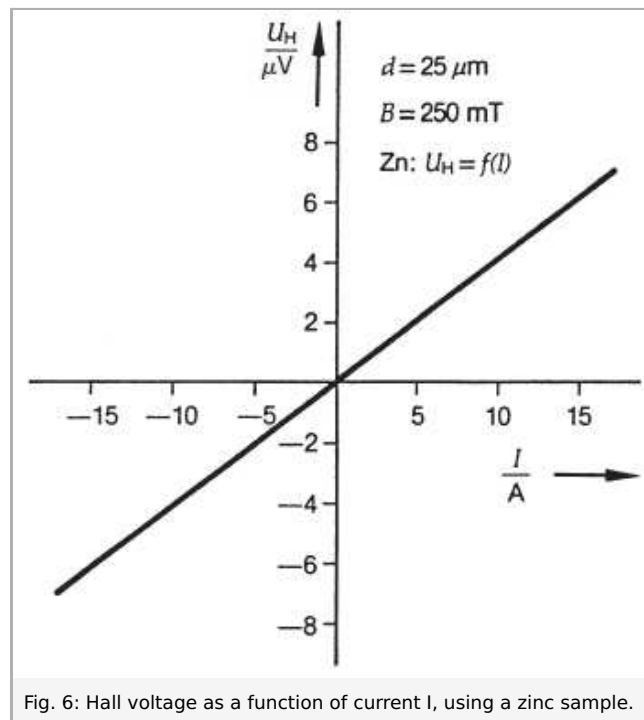

Fig. 5: Hall voltage as a function of magnetic induction  $B$ , using a zinc sample.

The zinc sample shows an anomalous Hall effect, in that the Hall voltage has a positive sign. The measurements shown in Fig. 5 confirm for zinc the relationship  $U_H \sim B$ . Linear regression using the expression  $U_H = a + bB$  gives a straight line with slope  $b = 20.7 \cdot 10^{-6} \text{ m}^2/\text{s}$  and standard deviation  $s_b = 0.4 \cdot 10^{-6} \text{ m}^2/\text{s}$ . From this, with  $d = 25 \cdot 10^{-6} \text{ m}$  and  $I = 12 \text{ A}$ , we obtain the Hall coefficient

$$R_H = (4.31 \pm 0.01) \cdot 10^{-11} \text{ m}^3/\text{As}$$



The measurements shown in Fig. 6 confirm for zinc the relation  $U_H \sim I$ . Linear regression using the expression  $U_H = a + bI$  gives a straight line with slope  $b = 0.40 \cdot 10^{-6} \text{ VA}$  and standard deviation  $s_b = 0.01 \cdot 10^{-6} \text{ V/A}$ . From this, with  $d = 25 \cdot 10^{-6} \text{ m}$  and  $B = 0.25 \text{ T}$ , we obtain the Hall coefficient

$$R_H = (4.00 \pm 0.01) \cdot 10^{-11} \text{ m}^3/\text{As}.$$

If the sample temperature is varied, we find, disregarding disturbing thermal voltages, that the Hall voltage in metals is not temperature dependent.

If the measured values of the Hall coefficients are compared with those given in the literature

(copper:  $R_H = -0.53 \cdot 10^{-10} \text{ m}^3/\text{As}$ ; zinc:  $R_H = 10 \cdot 10^{-10} \text{ m}^3/\text{As}$ ), it is noteworthy that the values for zinc show a distinct difference. This, it may be presumed, is attributable to disturbing secondary effects particularly at the contact points. Among these we may mention the Ettinghausen effect, the Peltier effect, the Seebeck effect, the first Righi-Leduc effect and the first Ettinghausen-Nernst effect. It is possibly due also to impurities in the test material (99.95% purity).