

# MT 157

## Assembly exercise: butterfly valve and non-return valve



The illustration shows the tool box with parts sets and tools. In the foreground the valves and fittings as they are assembled from the parts sets.

### Description

- **practical exercise based on the assembly of a butterfly valve and a non-return valve**
- **comprehensive and well-structured instructional material**

Non-return valves are used where flow reversal is not permitted. They must fully seal off the reverse direction while offering the lowest possible resistance in the forward flow direction. If the differential pressure of the medium falls below the value as dictated by the spring force, the valve closes. Non-return valves are installed in pipelines, and must close if the pressure drops or if a high back-pressure occurs. They are largely maintenance-free and low-wearing.

Butterfly valves are installed in the pipelines of water supply pumping stations and filter systems; in power plant cooling circuits; in the chemical industry for process water, including acidic and alkaline media; and in sewage treatment plants. They seal drip-tight like gate valves, and take up little space, as they are usually similar in size to the pipe cross-section.

Butterfly valves are constructed for ultra-large nominal widths (DN5300). Their operating pressure is normally in the range 4...16bar.

Butterfly valves may be operated by hand, by electric motor via a spur gear segment or worm gear, or by a hydraulic piston. The valve is closed by rotating its shaft through 90°.

The MT 157 practice kit forms part of the GUNT assembly, maintenance and repair practice line designed for training at technical colleges and in company training centres. A close link between theory and practice is key to the learning content.

MT 157 enables two typical industrially relevant valves and fittings to be assembled and disassembled. Students become familiar with all the components and their modes of operation. The parts are clearly laid out and well protected in a tool box. Systematic assembly and disassembly of the valves and fittings is practiced. The accompanying material details the individual steps involved in assembly, and provides additional information on the areas of application, mode of operation and design of the valves and fittings.

### Learning objectives/experiments

- design and function of a butterfly valve
- design and function of a non-return valve
- assembly and disassembly, including for the purposes of maintenance and repair
- replacing components (e.g. seal)
- comparison of 2 different valves and fittings
- reading and understanding engineering drawings and operating instructions
- leak testing (together with hydraulic valves and fittings test stand MT 162)

# MT 157

## Assembly exercise: butterfly valve and non-return valve



Non-return valve, disassembled

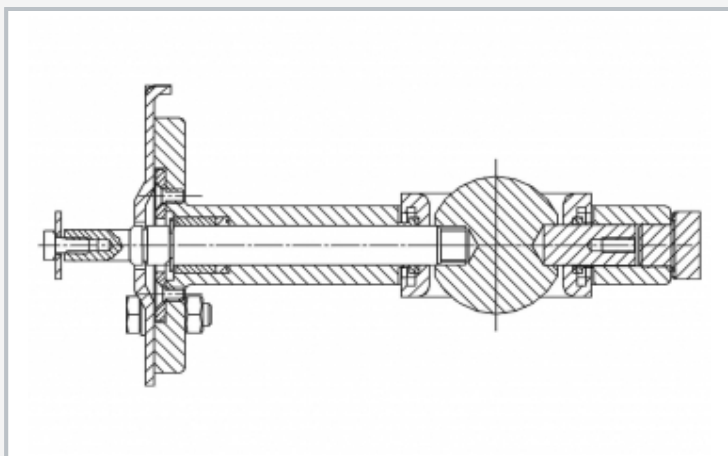

Sectional drawing of the butterfly valve

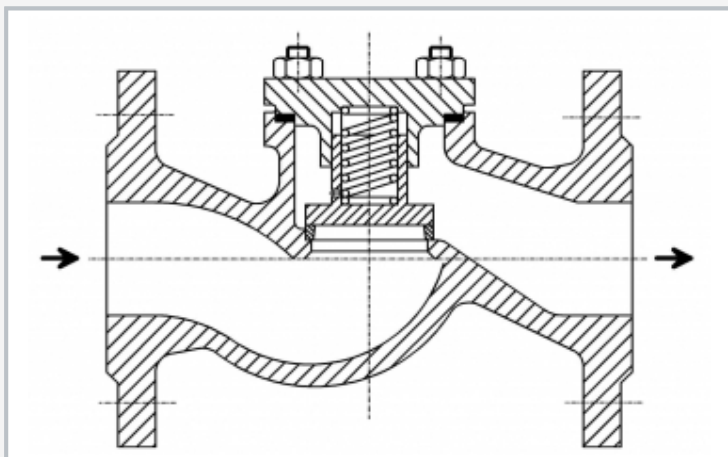

Sectional drawing of the non-return valve

### Specification

- [1] learning concept for assembly exercises on valves and fittings
- [2] butterfly valve with manual adjuster, as set of parts
- [3] typical non-return valve, as set of parts
- [4] complete assembly tool kit
- [5] valve parts and tools housed in a sheet-steel tool box
- [6] the kit forms part of the GUNT assembly, maintenance and repair practice line

### Technical data

Butterfly valve with flange connections

- DN40, PN16
- materials: housing: grey cast iron; disk, shafts: stainless steel; sleeve: rubber; hand lever: aluminium; bush: bronze

Non-return valve with flange connections:

- DN25, PN16
- materials: housing: grey cast iron; taper, spring: stainless steel; flat seal: graphite

LxWxH: 720x360x310mm (box)

Weight: approx. 35kg

### Scope of delivery

- 1 complete set of butterfly valve parts
- 1 set of replacement parts, consisting of: 1 seal, 1 sleeve, 8 bolts M8x25
- 1 complete set of non-return valve parts
- 1 set of tools, consisting of: 3 single-end wrenches: size 10, 13, 22; 1 Allen key, size 3; 1 slotted screwdriver 5,5x1; 1 set of circlip pliers, 1 soft-faced hammer
- 2 rectangular boxes for small parts
- 1 sheet-steel tool box with foam inlay
- 1 set of instructional material, consisting of: technical description of system, complete set of drawings with individual parts and parts list, description of assembly and disassembly processes, also in relation to repair operations

# MT 157

## Assembly exercise: butterfly valve and non-return valve

Optional accessories

051.16200

MT 162

Hydraulic valves and fittings test stand