

MT 158

Assembly exercise: ball valve and shut-off valve



The illustration shows the tool box with parts sets and tools. In the foreground the valves and fittings as they are assembled from the parts sets.

Description

- **practical exercise based on the assembly of a ball valve and a shut-off valve**
- **comprehensive and well-structured instructional material**

Shut-off valves, of the design presented here, are used to shut off and restrict the flow of media. They must be capable of complete flow shut-off. Closure of the valve should be such that the volumetric flow does not suddenly drop to zero in order to prevent shock loads. The valve taper is moved by the spindle and makes a metallic seal against the seating ring pressed into the housing. The spindle is sealed by a packing gland. The joint between the housing and the clamp cover is sealed by a flat seal.

Ball valves are used where media flows or pressures in pipelines need to be stopped quickly and easily, e.g. when valves and fittings are to be removed from a pressurised pipeline. They have a very low flow resistance when open, require little space due to the compact design, and have a self-cleaning sealing face. The sealing body is a ball with a cylindrical bore allowing full flow when the valve is fully open. The ball is rotated through 90° by way of a lever with spindle, enabling it to open or close the valve fully.

The practice kit MT 158 forms part of the GUNT assembly, maintenance and repair practice line designed for training at technical colleges and in company training centres. A close link between theory and practice is key to the learning content.

MT 158 enables two typical shut-off valves to be assembled and disassembled. Students become familiar with all the components and their modes of operation. The parts are clearly laid out and well protected in a tool box. Systematic assembly and disassembly of valves and fittings is practiced. The accompanying material details the individual steps involved, and provides additional information on the areas of application, mode of operation and design of the fittings.

Learning objectives/experiments

- design and function of a ball valve
- design and function of a shut-off valve
- assembly and disassembly, including for the purposes of maintenance and repair
- replacing components (e.g. seal)
- comparison of 2 different valves and fittings
- reading and understanding engineering drawings and operating instructions
- leak testing (together with hydraulic valves and fittings test stand MT 162)

MT 158

Assembly exercise: ball valve and shut-off valve

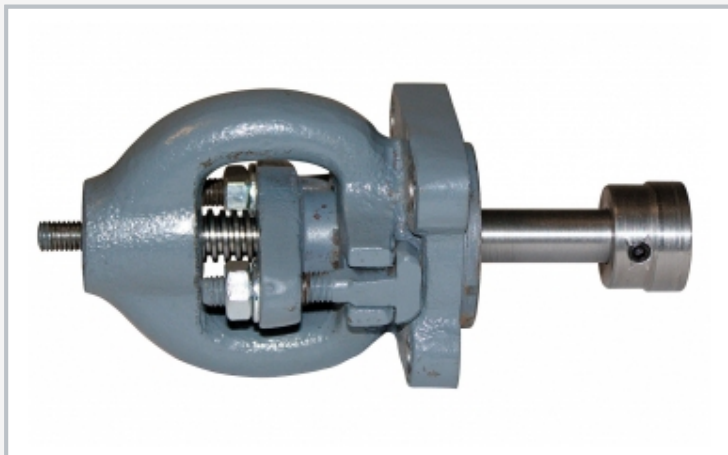

Assembly unit 2 of the shut-off valve, assembled

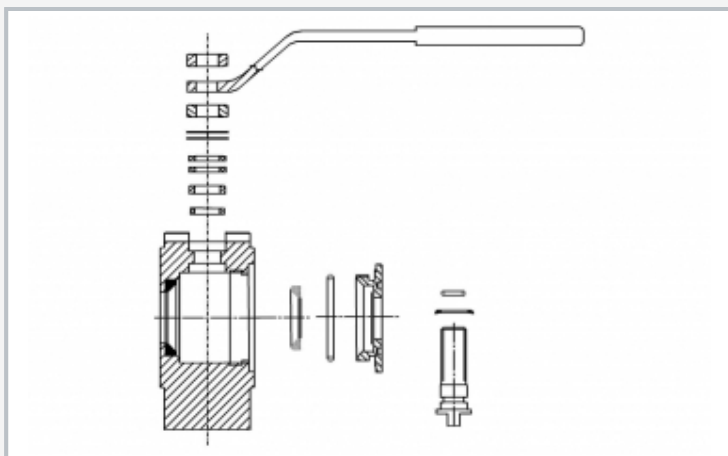

Assembly drawing of the ball valve

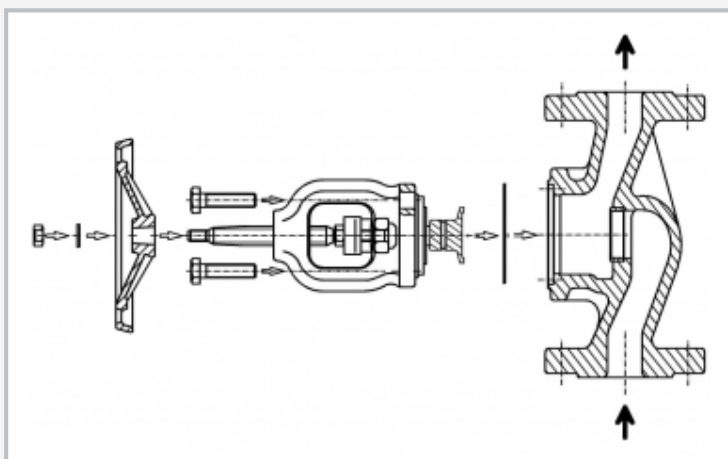

Assembly drawing of the shut-off valve

Specification

- [1] learning concept for assembly exercises on valves and fittings
- [2] shut-off valve, as set of parts
- [3] 2-way ball valve, as set of parts
- [4] complete assembly tool kit
- [5] valve parts and tools housed in a sheet-steel tool box
- [6] the kit forms part of the GUNT assembly, maintenance and repair practice line

Technical data

Shut-off valve with flange connections

- DN25, PN16
- housing, hand wheel, clamp cover, packing gland frame: grey cast iron
- taper, seating ring, spindle, ring segment etc.: stainless steel

Ball valve with flange connections

- DN25, PN16
- housing: C22
- ball: brass
- spindle, lever, disks etc.: galvanized steel

LxWxH: 720x360x310mm (box)

Weight: approx. 35kg

Scope of delivery

- 1 complete set of shut-off valve parts
- 1 set of replacement parts, consisting of:
 - 2 packing glands for spindle sealing
 - 16 steel balls for seating ring assembly
 - 2 seals
- 1 complete set of ball valve parts
- 1 set of replacement parts, consisting of:
 - 2 seal sets
- 1 set of tools, consisting of:
 - 2 single-end wrenches: size 13, 17
 - 1 Allen key, size 3
 - 1 pin-type face wrench, adjustable
 - 1 slotted screwdriver 5,5x1
 - 1 punch
 - 1 soft-faced hammer
 - 1 set of nuts and bolts
- 2 rectangular boxes for small parts
- 1 sheet-steel tool box with foam inlay
- 1 set of instructional material, consisting of:
 - 1 technical description of system
 - 1 complete set of drawings with individual parts and parts list
 - 1 description of assembly and disassembly processes, also in relation to repair operations

MT 158

Assembly exercise: ball valve and shut-off valve

Optional accessories

051.16200 MT 162 Hydraulic valves and fittings test stand