

MT 171

Assembly hydrodynamic journal bearing



The illustration shows the tool box with assembly kit and parts compartment insert. A fully assembled journal bearing is shown in the foreground.

Description

- **practical assembly kit of a hydrodynamic journal bearing**
- **part of the GUNT-Practice Line for assembly, maintenance and repair**

Journal bearings generally execute a sliding motion between a bearing journal and a bearing shell. This sliding motion is usually lubricated by an intermediate medium. Hydrodynamic journal bearings give wear-free continuous duty for large diameters at high speeds, and are suitable for high and shock-type loading. They are usually constructed as split bearings. Frictional heat occurring during operation must be dissipated by the lubricant.

MT 171 is a horizontally split hydrodynamic pedestal journal bearing. The bearing shells are supported by a spherical face in the bearing housing so as to ensure uniform transfer of any forces that arise on the bottom part of the housing. The journal bearing is lubricated by a loose lubricating ring. Standard commercially available mineral oils can be used. An auxiliary shaft is supplied together with the bearing as an aid to assembly and functional testing.

The MT 171 assembly kit is part of the GUNT-Practice Line for assembly, maintenance and repair, which has been designed for technical colleges and company training centres. The close link between theory and practice-based learning content is evident. MT 171 enables a hydrodynamic journal bearing to be assembled and disassembled. Students become familiar with all the components and how they work.

The individual parts are laid out clearly and are well protected in a tool box. The accompanying material details the individual steps involved in assembly, and provides additional information on the areas of application, mode of operation and design of the journal bearing.

Learning objectives/experiments

- function and design of a hydrodynamic journal bearing
- principles of lubrication and sealing elements
- assembly and disassembly, including for the purposes of maintenance and repair
- read and understand engineering drawings and operating instructions

MT 171

Assembly hydrodynamic journal bearing

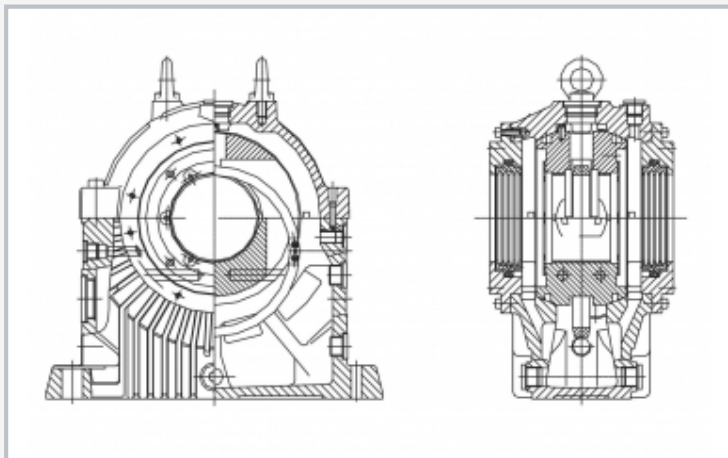

Sectional drawing of a hydrodynamic journal bearing

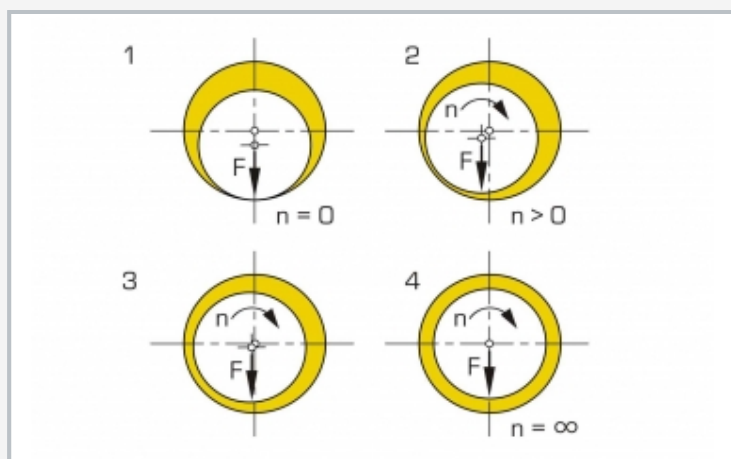

Operation of a hydrodynamic journal bearing: 1 to 4 build-up of a load-bearing oil film at increasing speed

Specification

- [1] assembly kit of an upright hydrodynamic journal bearing
- [2] part of the GUNT-Practice Line for assembly, maintenance and repair
- [3] journal bearing to DIN 31690
- [4] stainless-steel drive shaft
- [5] lubrication via oil lubricating ring
- [6] floating edge seal to the face of the shaft seal
- [7] contact surfaces of the housing halves sealed with non-hardening sealant
- [8] complete set of tools for assembly
- [9] journal bearing parts and tools housed in a sheet-steel tool box

Technical data

Bearing bore

■ $\varnothing=80\text{mm}$

Drive shaft

■ nominal diameter: $\varnothing=80\text{mm}$

Materials

■ bearing housing: grey cast iron

■ bearing shells: steel supports, coated with white metal

■ seal: ultra-heat-resistant, fibre-reinforced plastic

■ shaft: stainless steel

LxWxH: 690x360x312mm (tool box)

Weight: approx. 60kg

Scope of delivery

- 1 complete assembly kit of a hydrodynamic journal bearing
- 1 drive shaft
- 1 set of tools
- 1 sealing compound, non-hardening
- 1 set of instructional material