

# MT 180

## Assembly & maintenance exercise: centrifugal pump



The illustration shows the tool box with kit and tool inlay, and in the foreground the fully assembled pump.

### Description

- **practical exercise on the assembly and maintenance of a standard centrifugal pump**
- **comprehensive and well-structured instructional material**

Centrifugal pumps are rotodynamic pumps and operate normally primed. They are in widespread use, and are deployed primarily in the pumping of water. Their applications include use in shipbuilding, the process industries and in water supply systems. They are compact and relatively simple in design. The water is conveyed by centrifugal force generated by the rotation of the pump impeller. Standard pumps are – as the term suggests – standard items. As a result they are relatively inexpensive to purchase and maintain. In the lifecycle of a pump, maintenance and repair work is usually required as in many cases pumps are not considered as pure replacement items.

The MT 180 kit forms part of the GUNT assembly, maintenance and repair practice line designed for training at technical colleges and in company training centres. A close link between theory and practice is key to the learning content.

The kit is ideally suited to project based learning with a particular emphasis on 'hands-on' work. Independent working by the students is assisted and encouraged. Learning in a small team offers a useful learning format.

MT 180 enables a typical standard centrifugal pump to be assembled and maintained. Students become familiar with all the pump components and their modes of operation. The parts are clearly laid out in a tool box. Systematic assembly and disassembly of a pump is practiced.

The instructional material details the individual steps involved in the exercise, and provides additional information on the areas of application, mode of operation and design of the pump.

### Learning objectives/experiments

- design and function of a centrifugal pump and its components
- assembly and disassembly for maintenance and repair purposes
- replacing components (e.g. seals or bearings)
- troubleshooting, fault assessment
- planning and assessment of maintenance and repair operations
- reading and understanding engineering drawings and operating instructions

# MT 180

## Assembly & maintenance exercise: centrifugal pump

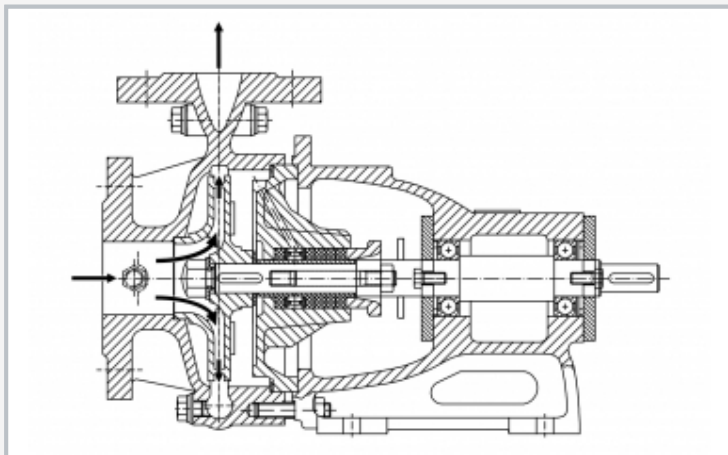

Sectional drawing of the centrifugal pump

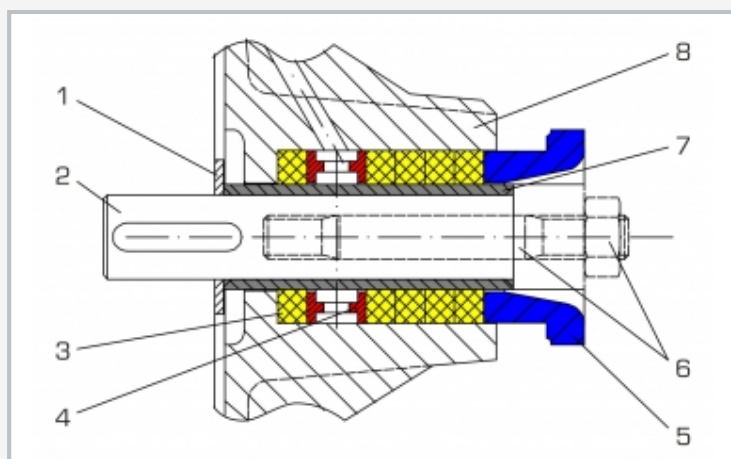

Packing gland: 1 disk, 2 shaft, 3 gland packing, 4 locking ring, 5 packing gland frame, 6 stud bolt with hexagon nut, 7 shaft sheath, 8 housing cover



Assembly of the centrifugal pump: fixing of the bearing cover with screws

### Specification

- [1] learning concept for maintenance and repair exercises on a single-stage, normally primed centrifugal pump with a spiral housing
- [2] pump according to DIN 24255
- [3] enclosed pump impeller with 5 blades, designed for pure liquids
- [4] pump shaft sealing, based on the gland principle
- [5] 2 assembly aids and a complete tool set
- [6] pump parts and tools housed in a tool box
- [7] the kit forms part of the GUNT assembly, maintenance and repair practice line

### Technical data

Single-stage centrifugal pump

- power consumption: max. 1100W
- max. flow rate: 19m<sup>3</sup>/h
- max. head: 25m
- speed: 3000min<sup>-1</sup>
- intake connection: DN50
- delivery connection: DN32
- housing and impeller: grey cast iron

LxWxH: 690x360x312mm (tool box)

Weight: approx. 35kg

### Scope of delivery

- 1 complete kit of a standard centrifugal pump
- 1 set of tools, consisting of: 2 combination wrenches size 13, 17; 1 double-ended box spanner size 24/26 with tommy bar; 1 bearing puller, three-arm; 1 slotted screwdriver, 5,5; 1 soft-faced hammer; 2 assembly aids for assembly / disassembly of bearings
- 1 set of replacement parts, consisting of: 1 flat seal; 1 gland packing
- 1 tool box with compartment insert and foam inlay
- 1 set of instructional material, consisting of: technical description of system, complete set of drawings with individual parts and parts list, description of maintenance and repair processes, suggested exercises; 1 operator's manual for the industrial pump