

MT 181

Assembly & maintenance exercise: Multistage centrifugal pump



The illustration shows the tool box with kit and tools. The fully assembled pump is shown in the foreground.

Description

- **practical exercise on the assembly and maintenance of a multistage centrifugal pump**
- **comprehensive and well-structured instructional material**

Centrifugal pumps are rotodynamic pumps and operate normally primed. They are in widespread use, and are deployed primarily in the pumping of water. Their range of applications include use in shipbuilding, the process industries and in water supply systems. Very high delivery pressures can be generated by connecting multiple impellers in series. Centrifugal pumps are compact and relatively simple in design. The water is conveyed by centrifugal force generated by the rotation of the pump impeller. In the lifecycle of a pump, maintenance and repair work is usually required as in many cases pumps are not considered as pure replacement items.

The MT 181 kit forms part of the GUNT assembly, maintenance and repair practice line designed for training at technical colleges and in company training centres. A close link between theory and practice is key to the learning content.

The kit is ideally suited to project-based learning with a particular emphasis on 'hands-on' work. Independent working by the students is assisted and encouraged. Learning in a small team offers a useful learning format.

MT 181 enables a typical multistage centrifugal pump to be assembled and maintained. Students become familiar with all the pump components and their modes of operation. The parts are clearly laid out in a tool box. Systematic assembly and disassembly of a pump is practiced.

The instructional material details the individual steps involved in the exercise, and provides additional information on the areas of application, mode of operation and design of the pump.

Learning objectives/experiments

- design and function of a multistage pump and its components
- assembly and disassembly for maintenance and repair purposes
- replacing components (e.g. seals, bearings or impellers)
- troubleshooting, fault assessment
- planning and assessment of maintenance and repair operations
- reading and understanding engineering drawings and operating instructions

MT 181

Assembly & maintenance exercise: Multistage centrifugal pump

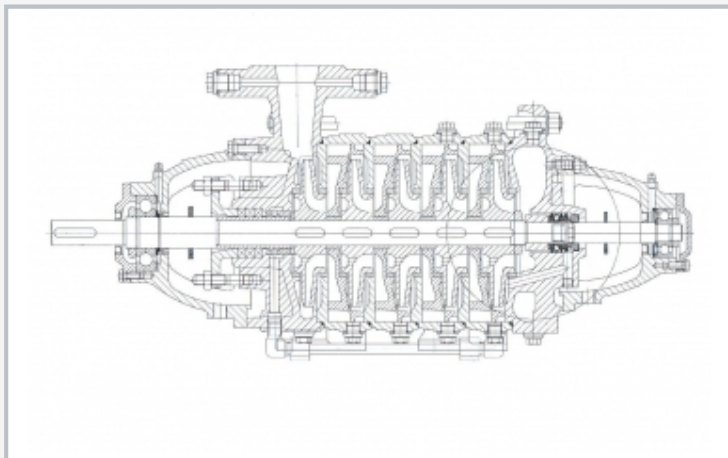

Sectional drawing of a similar multistage centrifugal pump (MT 181 has four stages; the intake and delivery connections are on the same side)

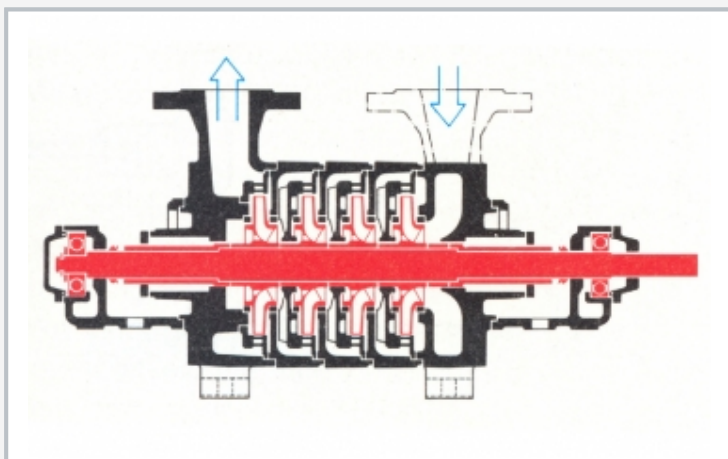

Schematic view of a four-stage centrifugal pump



Assembly of the four-stage centrifugal pump: assembling the packing gland rings

Specification

- [1] learning concept for maintenance and repair exercises on a four-stage, normally primed centrifugal pump
- [2] shaft sealing based on the gland principle (delivery side) and with floating ring seal (intake side)
- [3] driven by motor (not included) and clutch via pump shaft
- [4] 4 assembly aids and complete tool set
- [5] pump parts and tools housed in a tool box
- [6] the kit forms part of the GUNT assembly, maintenance and repair practice line

Technical data

Four-stage centrifugal pump

- power consumption: max. 1400W
- max. flow rate: 18m³/h
- max. head: 28m
- speed: 1450min⁻¹
- intake connection: DN50
- delivery connection: DN40
- housing and impellers: grey cast iron

LxWxH: 690x360x312mm (tool box)

Weight: approx. 58kg

Scope of delivery

- 1 complete kit of a 4-stage centrifugal pump
- 1 set of tools, consisting of: 8 combination wrenches size 10, 13, 17, 24, 27, 36, 2x size 19; 1 bearing puller, two-arm; 2 screwdrivers; 1 set of forcing pliers for shaft circlips; 1 punch; 1 soft-faced hammer; 1 tool for slot nut; 1 brace; 2 striker sleeves for assembly / disassembly of bearings
- 1 set of replacement parts, consisting of: 1 set of packing gland rings; 1 seal; 1 slot nut
- 1 tin of corrosion-proofing spray
- 1 box for small parts
- 1 tool box with foam inlay
- 1 set of instructional material, consisting of: technical description of system, complete set of drawings with individual parts and parts list, description of maintenance and repair processes, suggested exercises; 1 operator's manual for the industrial pump