

# MT 183

## Assembly & maintenance exercise: Diaphragm pump



The illustration shows the tool box with kit and tools. The fully assembled pump is shown in the foreground.

### Description

- **practical exercise on the assembly and maintenance of a diaphragm pump**
- **comprehensive and well-structured instructional material**

Diaphragm pumps are positive displacement pumps and operate in an oscillatory manner, normally primed. Since diaphragm pumps operate absolutely leakage-free, they are particularly suitable – provided the appropriate pump materials are used – for handling aggressive fluids such as acids and caustic solutions as well as radioactive, combustible, odorous and toxic liquids. Another advantage is that they can run dry. Diaphragm pumps are often used for volumetric metering (metering pumps).

The materials used in the construction of the diaphragm pump employed here make it particularly suitable for use in chemical engineering. It is equipped with a stroke length adjuster, and is deployed as a metering pump.

The MT 183 kit forms part of the GUNT assembly, maintenance and repair practice line designed for training at technical colleges and in company training centres. A close link between theory and practice is key to the learning content. The kit is ideally suited to project-based learning with a particular emphasis on 'hands-on' work. Independent working by the students is assisted and encouraged. Learning in a small team offers a useful learning format.

MT 183 enables a typical diaphragm pump to be assembled and maintained. Students become familiar with all the pump components and their modes of operation. The parts are clearly laid out in a toolbox. Systematic assembly and disassembly of a pump is practiced.

The instructional material details the individual steps involved in the exercise, and provides additional information on the areas of application, mode of operation and design of the pump.

### Learning objectives/experiments

- design and function of a diaphragm pump and its components
- assembly and disassembly for maintenance and repair purposes
- replacing components (e.g. seals or bearings)
- troubleshooting, fault assessment
- planning and assessment of maintenance and repair operations
- reading and understanding engineering drawings and operating instructions

# MT 183

## Assembly & maintenance exercise: Diaphragm pump

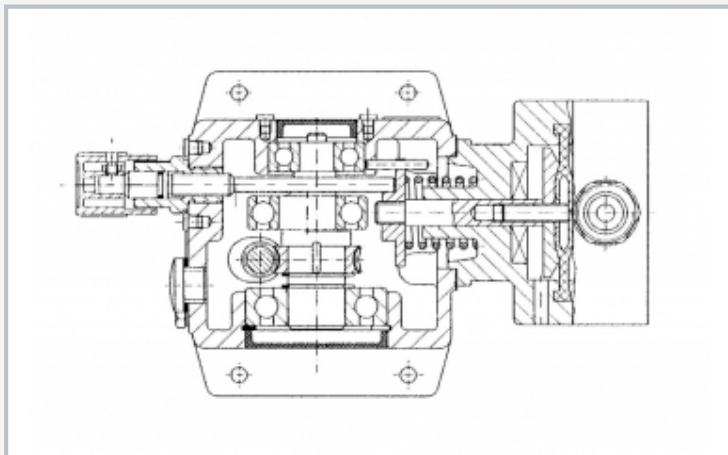

Sectional drawing of the diaphragm pump

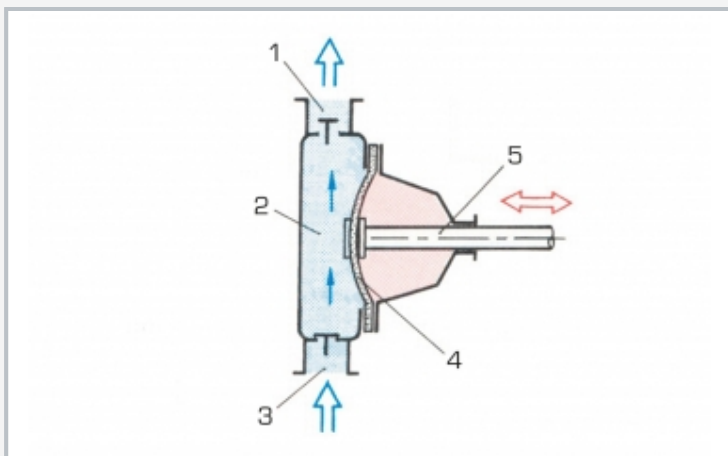

Operating principle of the single diaphragm pump: 1 outlet, 2 pumping chamber, 3 inlet, 4 diaphragm, 5 push rod



Assembly of the diaphragm pump: driving the eccentric into the housing (using a device)

### Specification

- [1] learning concept for maintenance and repair exercises on a single-diaphragm pump
- [2] diaphragm and push rod directly linked
- [3] flow setting by manual stroke length adjustment (including during operation)
- [4] manual drive with crank instead of a drive motor
- [5] pump parts and tools housed in a tool box
- [6] the kit forms part of the GUNT assembly, maintenance and repair practice line

### Technical data

Diaphragm pump

- flow rate: 0...2,4L/h
- max. head: 100m
- nominal stroke rate at 50Hz: 156min<sup>-1</sup>
- power consumption: max. 90W
- intake connection: DN5
- delivery connection: DN5
- pump materials

pump body: Polypropylene (PP)

double-ball valves: PP/glass fibre-reinforced plastic

valve balls: glass

valve seals: FPM

drive diaphragm: PTFE-lined

LxWxH: 690x360x312mm (tool box)

Weight: approx. 15kg

### Scope of delivery

- 1 complete kit of a diaphragm pump
- 1 set of tools, consisting of: 4 combination wrenches size 22, 27, 2x8; 3 Allen keys size 2.5, 3, 4; 1 screwdriver; 1 bearing puller, three-arm; 1 set of forcing pliers for inner circlips; 1 set of forcing pliers for outer circlips; 1 soft-faced hammer; 2 striker sleeves for assembly/disassembly of bearings
- 1 hand drive
- 1 flange seal
- 1 tin of corrosion-proofing spray
- 1 box for small parts
- 1 tool box with foam inlay
- 1 set of instructional material, consisting of: technical description of system, complete set of drawings with individual parts and parts list, description of maintenance and repair processes, suggested exercises; 1 operator's manual for the industrial pump