

MT 210

Assembly & maintenance exercise: refrigeration



Learning objectives/experiments

- reading and understanding technical documentation
- planning and executing assembly steps and processes
- making pipe joints in accordance with a system diagram
- carrying out electrical installation in accordance with a circuit diagram
- commissioning and checking the refrigeration system after successful assembly (in conjunction with ET 150.01)
- familiarisation with the function of a refrigeration system as a system and its components as system components
- fault analysis: fault finding, fault evaluation and repair
- planning, executing and evaluating maintenance processes

- in conjunction with ET 150.01
 - ▶ evacuating and filling refrigeration systems

Description

- **study project with high practical relevance**
- **suitable for training in metal and electrical professions**
- **interdisciplinary and covering several subject areas**
- **setup of a refrigeration system from individual components**

Using MT 210 trainees can learn working within a complex project. This involves the planning, implementation and checking of processes related to assembly, commissioning and maintenance. The assembly relates to refrigeration installation: installation of the LP and HP pressure switches, the expansion valve and the pipework of the refrigeration circuit. The pipe joints are not soldered but bolted. The electrotechnical installation includes the wiring and connection of all units and switching elements.

For assembly the tool set ET 150.02, for commissioning the system the filling and evacuation equipment ET 150.01 are required.

The fully assembled system MT 210 represents a fully functional, temperature-controlled refrigeration system with refrigeration chamber and electrical thermostat. Repeated assembly and disassembly are possible.

The experiment is arranged on a workbench with drawers for storing the components and tools. Assembly panel and refrigeration chamber are mounted on a frame. Frame, condensing unit and switch cabinet are bolted permanently to the working surface. The refrigeration and electrical components are attached to the aluminium assembly panel.

The well-structured instructional material sets out the fundamentals and provides a step-by-step guide through the exercises.

The fully assembled MT 210 presents a real, fully functional temperature-controlled cooling system with cooling chamber and electric thermostat. The system is supplied in kit form.

MT 210

Assembly & maintenance exercise: refrigeration

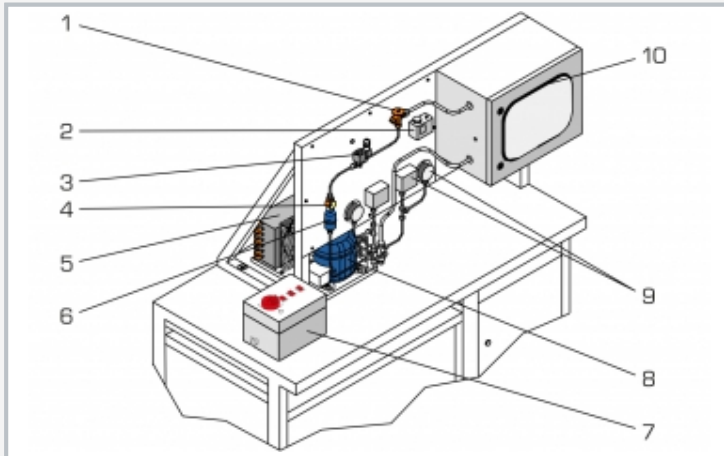

1 expansion valve, 2 thermostat, 3 solenoid valve, 4 sight glass, 5 condenser with fan, 6 filter/drier, 7 switch cabinet, 8 compressor, 9 pressure switch with manometer, 10 refrigeration chamber with sight window and integrated evaporator

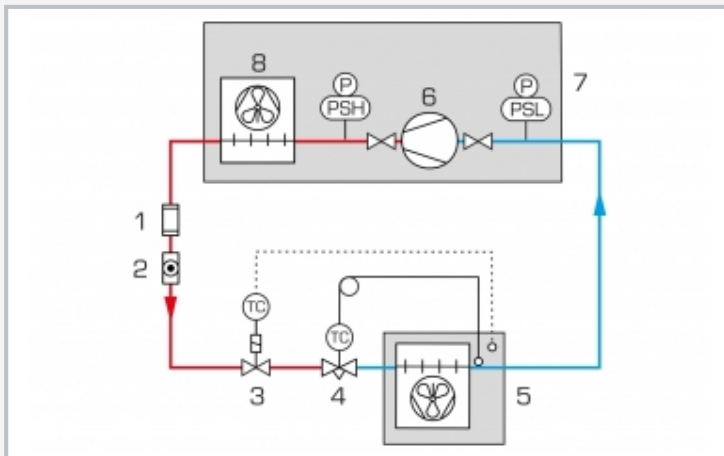

1 filter/drier, 2 sight glass, 3 thermostat, 4 expansion valve, 5 refrigeration chamber with evaporator, 6 compressor, 7 condensing unit, 8 condenser;
P pressure, PSL, PSH pressure switch; blue: low pressure, red: high pressure



Leak test at the expansion valve of the fully assembled system

Specification

- [1] assembly project for the training of mechatronics engineers for refrigeration
- [2] setup of a refrigeration system with refrigeration chamber from a complete set of components
- [3] temperature control via thermostat
- [4] air-cooled condensing unit with compressor
- [5] refrigeration chamber with integrated show case evaporator and fan
- [6] refrigeration chamber with large sight window
- [7] assembly panel to mount the refrigeration and electrical components
- [8] electrical assembly in accordance with the circuit diagram
- [9] easy pipeworking of the refrigeration circuit using bolted pipe joints
- [10] workbench with drawers to store the components
- [11] refrigerant R134a, CFC-free
- [12] the training set is part of the GUNT practical series for assembly, service and maintenance

Technical data

Condensing unit

- power consumption: 190W
- refrigeration capacity: 373W at 5°C evaporation temperature
- receiver: approx. 1L

Show case evaporator

- capacity: 50W at $t_0 = -6^\circ\text{C}$, $T = 8\text{K}$
- transfer area: $1,06\text{m}^2$

Refrigeration chamber with sight window

- LxWxH: 480x280x390mm

Aluminium assembly panel

- LxW: 710x500mm

Thermostatic expansion valve, adjustable

Thermostat, adjustable: $-30 \dots 15^\circ\text{C}$

230V, 50Hz, 1 phase

120V, 60Hz, 1 phase

LxWxH: 1.530x750x1.670mm

Weight: approx. 155kg

Scope of delivery

- 1 workbench with drawers, switch cabinet, condensing unit, assembly panel and refrigeration chamber
- 1 kit consisting of all necessary components and installation material
- 1 set of instructional material, consisting of: technical system description, set of drawings with individual components and parts list, description of the assembly, service and maintenance processes

MT 210

Assembly & maintenance exercise: refrigeration

Optional accessories

061.15001 ET 150.01 Refrigerant Filling and Evacuation Equipment

061.15002 ET 150.02 Tool Set