

PT 105

Dimensional Metrology I: Training Kit 5



Description

- **tried and tested dimensional metrology exercises**
- **several test aids and 10 test pieces**
- **comprehensive and well-structured instructional material**

This dimensional metrology practice kit is designed for practical training in the metalworking trades.

The kit offers the advantage of being ready for use immediately; it contains everything required for the exercises. The test pieces used are stainless steel shafts with various protrusions. They were manufactured with the accuracy of CNC parts. The kit includes ten shafts, all of which differ to a minor degree in dimensions and each of which is individually marked.

All parts are clearly laid out and well protected on a plastic storage system. The storage systems are stackable, providing for space-saving storage.

Learning objectives/experiments

- familiarisation with the various measuring devices
- measurement of pre-determined lengths
- measurement of pre-determined diameters
- measurement of pre-determined radii
- dimensional checking with block gauges
- keeping a measurement log
- estimating measurement variations
- identifying typical errors

PT 105

Dimensional Metrology I: Training Kit 5

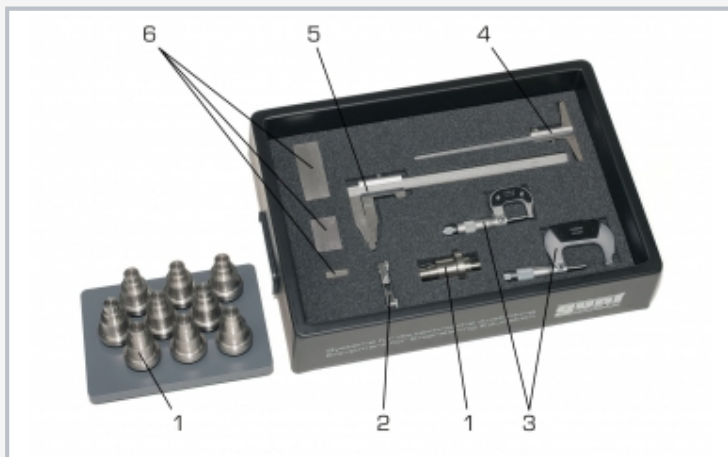

1 test piece, 2 radius gauges, 3 external micrometer, 4 depth caliper gauge, 5 caliper gauge, 6 block gauge

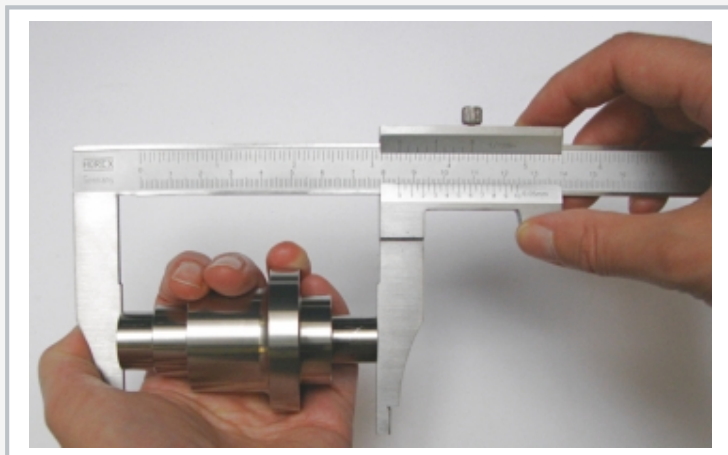

Measurement of length using a caliper gauge



Measurement of radius using a convex radius gauge

Specification

- [1] practice kit for dimensional metrology in the metal-working trades
- [2] measurement exercises on a stainless steel shaft
- [3] instructional kit complete with test pieces and measuring aids
- [4] 10 test pieces, each of different dimensions
- [5] plastic storage system to house all parts
- [6] detailed instructional material

Technical data

Test pieces

- 6 lengths
- 7 diameters and radii measurable

Vernier caliper gauge: 0...200mm

Depth caliper gauge: 0...150mm

External micrometer

- 0...25mm
- 25...50mm

Radius gauges: 1...7mm concave and convex

Block gauges

- 10mm
- 50mm
- 90mm
- accuracy to DIN 861/2

LxWxH: 500x350x110mm (storage system)

Weight: approx. 7kg

Scope of delivery

- 1 storage system with foam inlay
- 2 caliper gauges
- 2 external micrometers
- 1 set of radius gauges
- 3 block gauges
- 10 test pieces (shafts)
- 1 set of instructional material