

PT 500.05

Brake & load unit



Description

- generation of a loading torque
- two speed and torque ranges
- vented magnetic particle brake with display and control unit

Many vibration phenomena can only be achieved when the system is under load. The brake and load unit is used to generate vibration as a function of torque, e.g. in toothed gearing mechanisms or electric motors.

It consists of a magnetic particle brake and an electric display and control unit. The braking torque can be finely adjusted on the display and control unit. The exciter current is applied as a measure of the braking torque and is indicated digitally on a display.

An integrated belt drive, with a free shaft, provides the brake with two torque and speed ranges. The energy is converted by the brake into heat and discharged to the ambient air by a fan. The brake can be quickly and precisely mounted on the slotted plate of the PT 500 base unit.

PT 500.05 is used with the following kits:

- PT 500.13 Couplings
- PT 500.14 Belt drive
- PT 500.15 Damage to gears
- PT 500.19 Electromechanical vibrations

PT 500.05

Brake & load unit

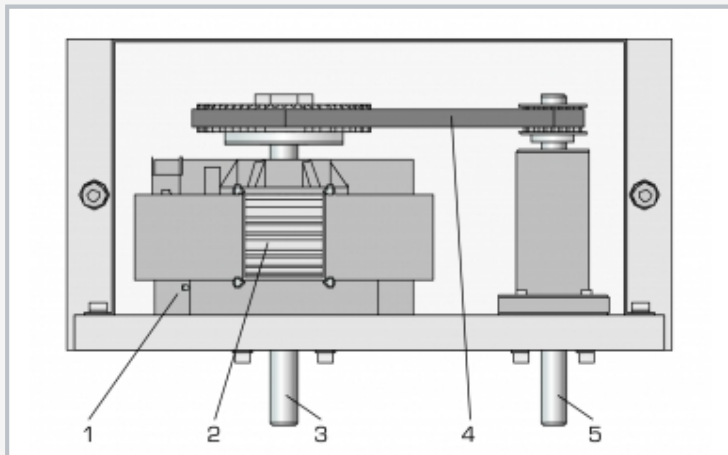

1 magnetic particle brake, 2 fan, 3 shaft for direct connection of brake, 4 belt drive, 5 shaft for connection of brake via belt drive

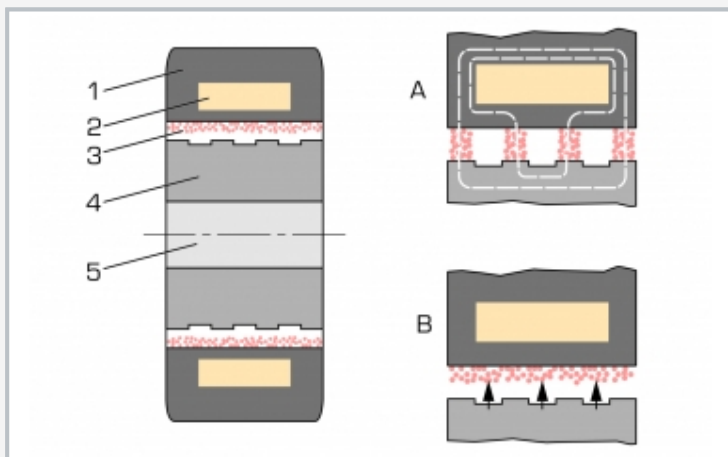

Principle of operation of a magnetic particle brake: 1 stator, 2 exciter coil, 3 gap with magnetic particles, 4 rotor, 5 shaft; A current flows: magnetic particles connect rotor and stator, resulting in friction and braking, B current flow interrupted: magnetic particles are pressed against the stator by centrifugal force, and the rotor can rotate



The illustration shows PT 500.05 together with PT 500, PT 500.01, PT 500.15 and PT 500.04.

Specification

- [1] brake and load unit for the machinery diagnostic training system
- [2] magnetic particle brake
- [3] display and control unit with exciter current display
- [4] potentiometer to adjust braking torque
- [5] integrated belt drive for second speed and torque range
- [6] temperature protection and fan overheating protection
- [7] stackable storage system to house the components

Technical data

Continuous braking power: approx. 450W/3000min⁻¹
Transmission ratio between brake shafts: i=3

Direct brake operation

- speed range: 200...2000min⁻¹
- braking torque: 1...10Nm

Operation via belt drive

- speed range: 600...6000min⁻¹
- braking torque: 0,3...3,3Nm

230V, 50Hz, 1 phase

230V, 60Hz, 1 phase; 120V, 60Hz, 1 phase

UL/CSA optional

LxWxH: 460x410x200mm (display and control unit)

LxWxH: 600x400x320mm (storage system)

Weight: approx. 30kg

Scope of delivery

- 1 magnetic particle brake
- 1 display and control unit
- 1 storage system with foam inlay
- 1 manual