

PT 500.15

Damage to gears kit



Description

- vibration analysis of tooth damage
- fault localisation on gears

The PT 500.15 accessory setup is used to simulate typical damage to gears and study its effects on vibration behaviour. Various gear sets with tooth damage are supplied for this purpose. Undamaged gear sets are provided for comparative purposes. The difference between spur toothed and helical gearing can also be demonstrated. The influence of the centre distance and backlash can be studied using adjustable bearing plates. The type of lubrication has a significant influence on the vibration signal, so grease or gear oil can be used for lubrication.

The housing, with holes to accommodate sensors, is used for vibration experiments. The transparent housing cover allows the gear to be observed in operation without taking vibration measurements.

The PT 500.05 brake and load unit will be required to subject the gear unit to load.

The accessory setup is mounted on the base plate of the machinery diagnostic base system PT 500.

To measure and evaluate the experiment, the computerised vibration analyser PT 500.04 is required. It includes all the necessary sensors, a measuring amplifier and analysis software to record the vibration phenomena.

Learning objectives/experiments

- identification of gear damage from vibration behaviour
- influence of gearing type
 - ▶ spur toothed
 - ▶ helical
- localisation of damage
- influence of lubrication
- influence of centre distance and of backlash
- understanding and interpreting frequency spectra
- use of a computerised vibration analyser

PT 500.15

Damage to gears kit

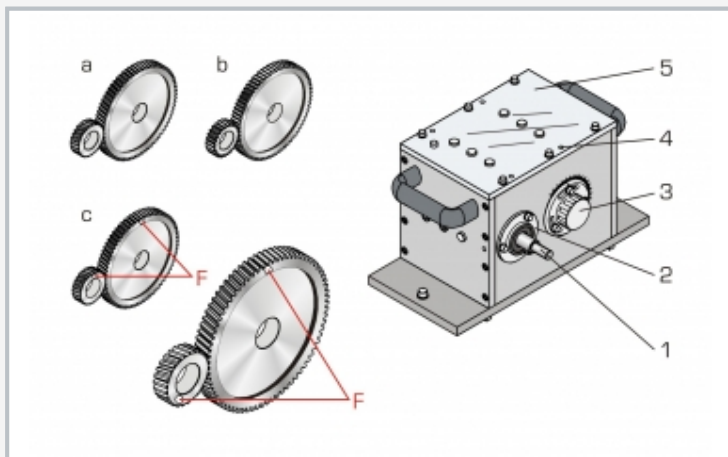

1 shaft end, 2 bearing cover with shaft gland, 3 bearing cover with centre distance adjustment facility, 4 tapped hole for vibration sensor, 5 transparent gear unit cover; a helical gear set, b spur toothed gear set, c damaged gear sets; F fault



The illustration shows PT 500.15 together with PT 500, PT 500.01, PT 500.05 and PT 500.04.

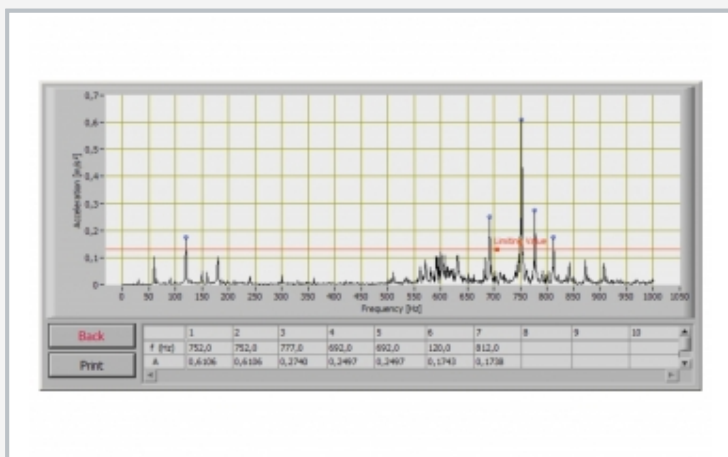

Spectrum of a spur toothed gear at 1800min⁻¹: tooth gearing frequency 752Hz

Specification

- [1] investigation of the vibration behaviour of gears
- [2] two-shaft gear unit
- [3] 2 damaged and 2 undamaged gear sets
- [4] spur toothed and helical gearing
- [5] housing with sensor holes
- [6] transparent housing cover
- [7] gear can be lubricated with grease or oil
- [8] loading of experimental setup with brake and load unit PT 500.05
- [9] accessory set for PT 500 machinery diagnostic training system
- [10] stackable storage system to house the components

Technical data

Transmission ratio i: 1:3
 Centre distance adjustable
 Reference profile to DIN 867

Spur toothed gear sets

- gear wheel: 75 teeth on each, m=2mm
- pinion: 25 teeth on each, m=2mm

Helical gear sets

- gear wheel: 75 teeth on each, m=2mm
- pinion: 25 teeth on each, m=2mm
- helix angle: 10°

LxWxH: 600x400x320mm (storage system)
 Weight: approx. 25kg

Scope of delivery

- 1 gearbox
- 1 transparent housing cover
- 1 housing cover with sensor holes
- 4 gear wheels
- 4 pinions
- 1 motor oil SAE 10W 40, 1,5L
- 1 storage system with foam inlay
- 1 manual

PT 500.15

Damage to gears kit

Required accessories

052.50000	PT 500	Machinery diagnostic system, base unit
-----------	--------	--

Optional accessories

052.50004	PT 500.04	Computerised vibration analyser
052.50005	PT 500.05	Brake & load unit