

PT 500.16

Crank mechanism kit



Description

- vibrations of crank drives
- bearing clearance or slack in oscillating machine components

Crank drives are frequently used in compressors and pumps. They cause vibration due to the oscillating masses and forces. Under the alternating stress in the drive mechanism, bearing clearance, for example, can generate shock impacts with high-frequency exciter spectra. In addition, free mass forces generate harmonic vibrations due to their non-linear kinematics.

The PT 500.16 accessory set enables the stroke, mass balance and bearing clearance on the crosshead to be adjusted. The speed is adjusted using the base unit PT 500. Gas forces such as occur in compressors or combustion engines can be simulated using springs. Experiments with gas forces require higher torques which are attained by reducing the speed of the drive motor from the base unit PT 500. This reduction is achieved either with the PT 500.14 belt drive or the PT 500.15 gear unit.

The transmission of alternating torque in toothed gearing mechanisms can be investigated together with accessory set PT 500.15 (for investigating damage to gears).

The accessory set is mounted on the base plate of the machinery diagnostic base system PT 500.

To measure and evaluate the experiment, the computerised vibration analyser PT 500.04 is required. It includes all the necessary sensors, a measuring amplifier and analysis software to record the vibration phenomena.

Learning objectives/experiments

- experimental modal analysis of mechanical systems
- familiarisation with the envelope analysis
- influence of bearing clearance and shock impact
- inconsistent torque characteristic
- wear measurement on piston rods
- understanding and interpreting frequency spectra
- use of a computerised vibration analyser
- in conjunction with PT 500.15
 - ▶ transmission of alternating torque in toothed gearing mechanisms
- in conjunction with PT 500.14 or PT 500.15
 - ▶ influence of gas forces on the vibration spectrum

PT 500.16

Crank mechanism kit

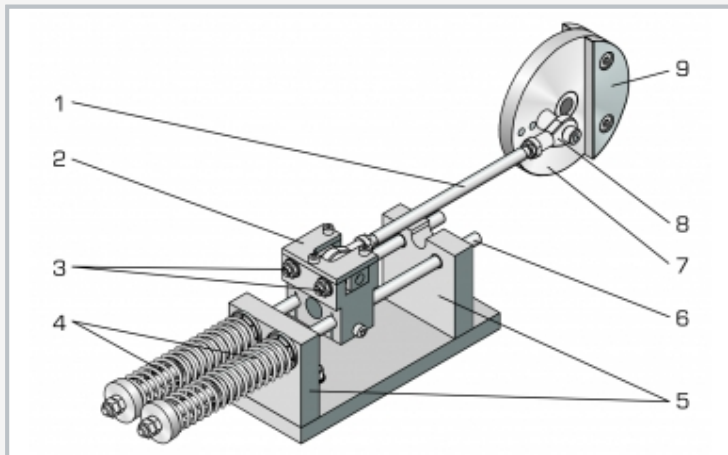

1 connecting rod, 2 crosshead, 3 adjustment of bearing clearance, 4 pressure spring, 5 bearing block with journal bearing, 6 piston rod, 7 crank disk, 8 articulated head, 9 balance mass



The illustration shows PT 500.16 together with PT 500, PT 500.01 and PT 500.04.

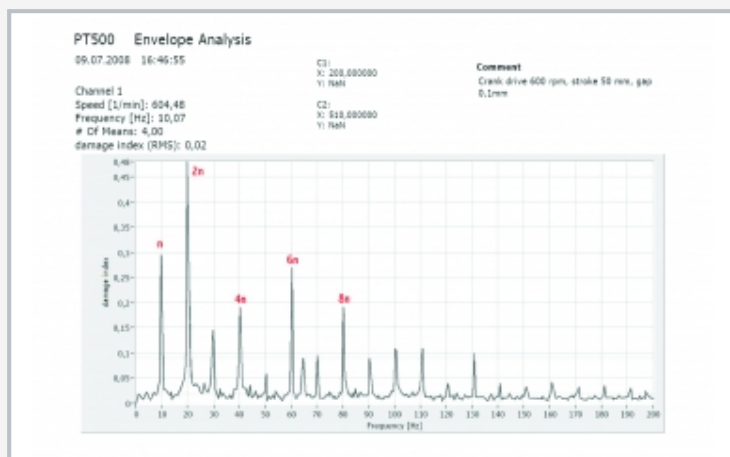

Envelope analysis on crank drive with clearance at 600min⁻¹. Dominant is the 2nd order 2n with harmonic waves 4n, 6n, 8n etc.

Specification

- [1] investigation of the vibrations of crank drives
- [2] crank drive with adjustable stroke
- [3] interchangeable bearing bushes permit simulation of bearing clearance
- [4] springs simulate gas forces
- [5] can be used together with gear damage accessory set PT 500.15
- [6] belt drive PT 500.14 or gear unit PT 500.15 required for experiment with gas forces
- [7] accessory set for PT 500 machinery diagnostic training system
- [8] stackable storage system to house the components

Technical data

Stroke: 50 - 75 - 100mm

Balance mass total

- 490g, rated for operation with 50mm stroke

Bearing clearance: 0...1mm

Pressure spring

- relaxed length: 170mm
- spring stiffness: R=0,55N/mm

LxWxH: 600x400x170mm (storage system)

Weight: approx. 8kg

Scope of delivery

- 1 crank drive
- 2 springs
- 2 balance masses
- 1 set of tools
- 1 storage system with foam inlay
- 1 manual

PT 500.16

Crank mechanism kit

Required accessories

052.50000	PT 500	Machinery diagnostic system, base unit
-----------	--------	----------------------------------------

Optional accessories

052.50004	PT 500.04	Computerised vibration analyser
052.50014	PT 500.14	Belt drive kit
052.50015	PT 500.15	Damage to gears kit