

PT 500.18

Vibrations in fans kit



Description

- vibration measurements on fans
- simulation of blade-induced vibrations

Vibration measurements on fans and blowers play a major role in field monitoring operations. In addition to the usual signals caused by bearings and imbalance, the vibrations induced by the fan blades can be measured. The vibrations are induced by inhomogeneous flow fields.

The PT 500.18 accessory set induces the vibrations magnetically. Three fan rotors with differing numbers of blades can be investigated. A guard plate covers the rotating fans. An obliquely-mounted inertia disk is used to investigate the gyroscopic effect. Just as in actual practice, the fan model can also be driven directly via a flexible coupling or by the belt drive PT 500.14.

The accessory set is mounted on the base plate of the machinery diagnostic base system PT 500.

To measure and evaluate the experiment, the computerised vibration analyser PT 500.04 is required. It includes all the necessary sensors, a measuring amplifier and analysis software to record the vibration phenomena.

Learning objectives/experiments

- vibration measurement on fans
- measurement of blade pass frequency
- identification of the vibration induced by the blades from the vibration spectrum
- effect of dynamic imbalance on the fan
- understanding and interpreting frequency spectra
- use of a computerised vibration analyser

PT 500.18

Vibrations in fans kit

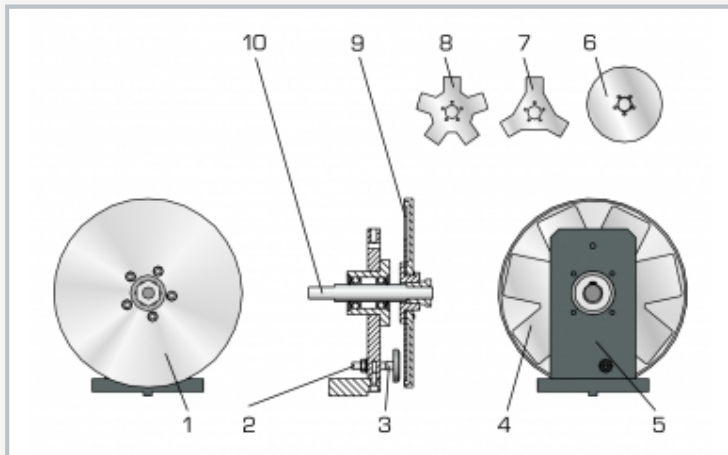

1 guard disk, 2 adjuster screw for gap between magnet and blades, 3 permanent magnet, 4 fan rotor with 7 blades, 5 bearing block, 6 mass disk to simulate axial forces, 7 fan rotor with 3 blades, 8 fan rotor with 5 blades, 9 fan blade, 10 fan shaft

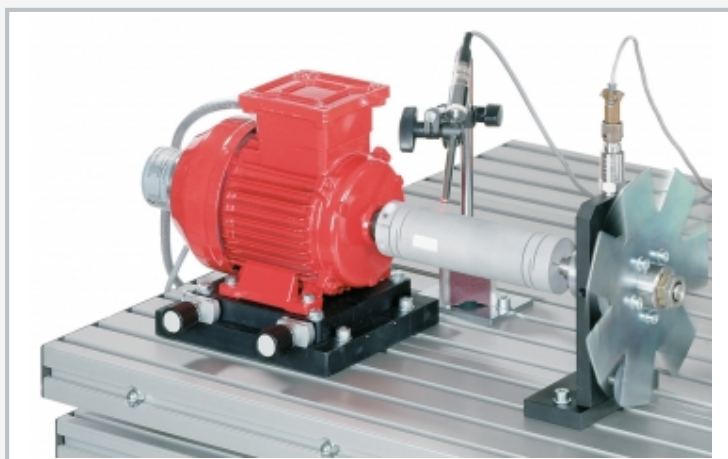

The illustration shows PT 500.18 together with PT 500 and PT 500.01.

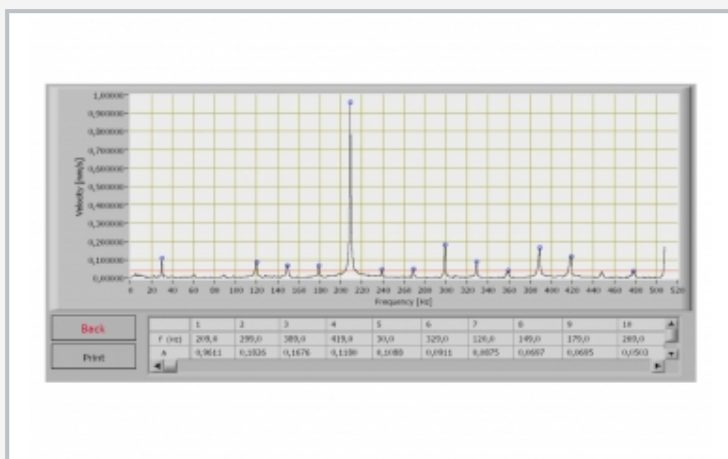

Frequency spectrum of a fan rotor with 7 blades: clear blade passing frequency at 210Hz

Specification

- [1] investigation of the vibrations of fans
- [2] model of an axial fan with blades
- [3] magnetic induction of blade forces
- [4] obliquely-mounted inertia disk to investigate gyroscopic effects
- [5] 3 fan rotors with different numbers of blades
- [6] guard disk for fan rotors
- [7] gap between magnet and blades adjustable
- [8] can be used with belt drive PT 500.14
- [9] accessory set for PT 500 machinery diagnosis training system
- [10] stackable storage system to house the components

Technical data

Sheet-steel fan rotor

- 3 blades
- 5 blades
- 7 blades
- diameter: 204mm
- max. speed: 3000min⁻¹

Protective disk, made of aluminium

- Ø=220mm

LxWxH: 400x300x320mm (storage system)

Weight: approx. 6kg

Scope of delivery

- 3 fan rotors
- 1 mass disk
- 1 holder
- 1 guard disk
- 1 storage system with foam inlay
- 1 manual

PT 500.18

Vibrations in fans kit

Required accessories

052.50000	PT 500	Machinery diagnostic system, base unit
-----------	--------	--

Optional accessories

052.50004	PT 500.04	Computerised vibration analyser
052.50014	PT 500.14	Belt drive kit